

# Introduction: Deciphering Complexity in Molecular Architecture

**Author:** BenchChem Technical Support Team. **Date:** April 2026

## Compound of Interest

Compound Name: *4-Bromo-2-iodo-6-nitroanisole*

CAS No.: *1935459-09-8*

Cat. No.: *B2579974*

[Get Quote](#)

In the landscape of drug development and materials science, the precise structural elucidation of polysubstituted aromatic compounds is a cornerstone of innovation. **4-Bromo-2-iodo-6-nitroanisole** represents a model of significant complexity, featuring a benzene ring adorned with four distinct substituents, each exerting a unique electronic influence. Nuclear Magnetic Resonance (NMR) spectroscopy stands as the preeminent analytical technique for unambiguously determining the constitution of such molecules in solution.<sup>[1][2]</sup>

This technical guide provides a comprehensive analysis of the proton (<sup>1</sup>H) NMR spectrum of **4-bromo-2-iodo-6-nitroanisole**. We will move beyond a simple description of the spectrum to a detailed, predictive analysis grounded in fundamental principles. This document is designed for researchers, scientists, and professionals who require a deep, mechanistic understanding of how molecular structure translates into spectral data. We will explore the causal relationships between substituent electronics and proton chemical environments, present a robust experimental protocol for data acquisition, and offer a systematic approach to spectral interpretation.

## Part 1: Molecular Structure and Substituent Effects

To predict the  $^1\text{H}$  NMR spectrum, we must first dissect the molecule's structure and the electronic contributions of its substituents. The anisole core is substituted at positions 2, 4, and 6, leaving two protons on the aromatic ring at positions 3 and 5.

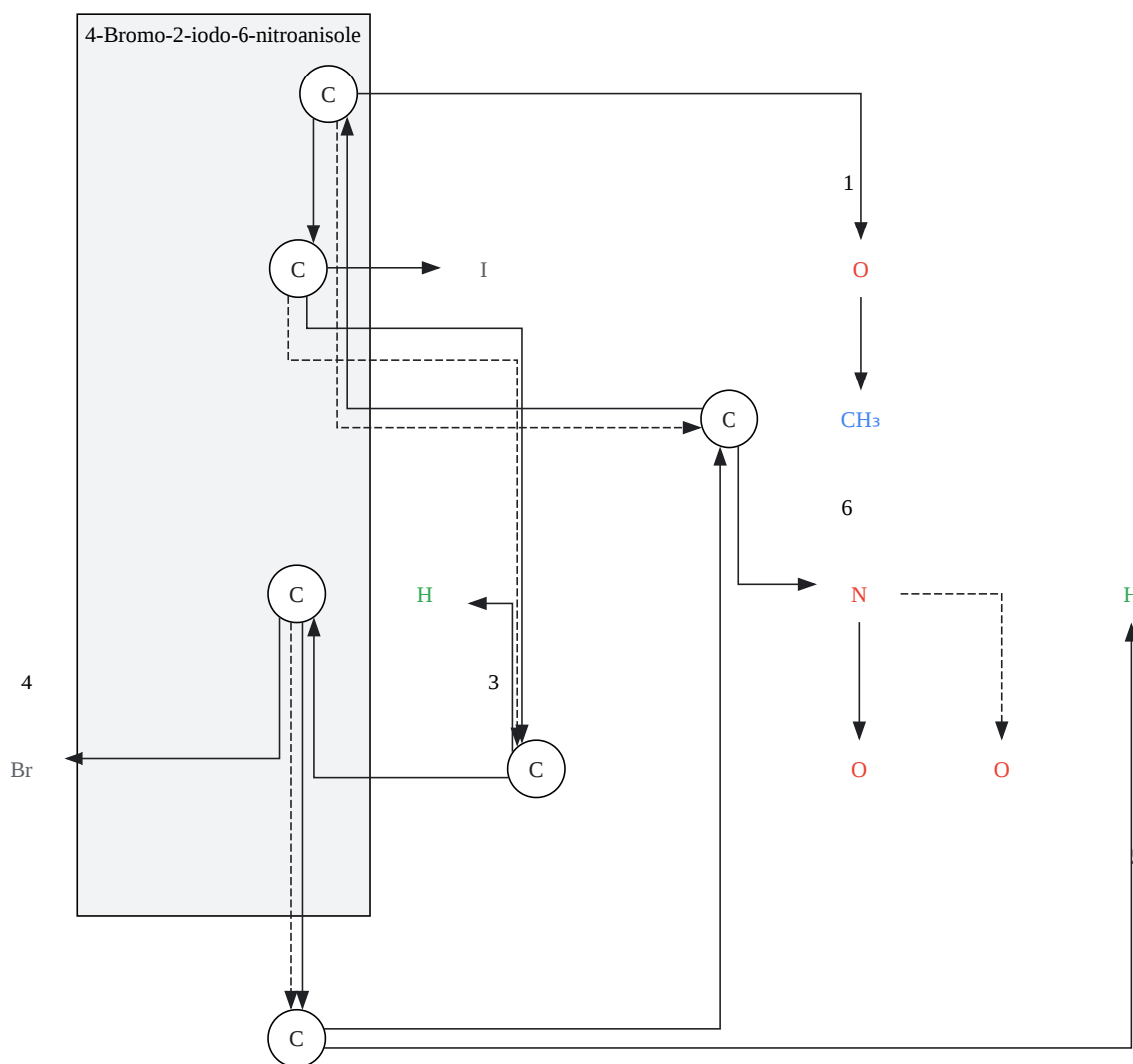

[Click to download full resolution via product page](#)

Caption: Molecular structure of **4-Bromo-2-iodo-6-nitroanisole**.

The chemical environment of each proton (H-3 and H-5) is dictated by the additive effects of the four substituents.

- Methoxy Group (-OCH<sub>3</sub>): This group is electron-donating through resonance (+R effect) and weakly electron-withdrawing through induction (-I effect). The resonance effect dominates, increasing electron density primarily at the ortho and para positions.[3]
- Nitro Group (-NO<sub>2</sub>): The nitro group is one of the most powerful electron-withdrawing groups, acting through both resonance (-R effect) and induction (-I effect).[4][5] It strongly deshields nearby protons, causing their signals to appear significantly downfield (at a higher ppm value).[3][6][7]
- Halogens (-Br, -I): Bromine and Iodine are electron-withdrawing via induction (-I) but electron-donating via resonance (+R). Their inductive effect is dominant, leading to a net deactivation of the ring. Their influence on proton chemical shifts is complex, involving electronegativity, anisotropy, and steric effects.[8][9][10]

## Part 2: Theoretical <sup>1</sup>H NMR Spectrum Prediction

Based on these first principles, we can construct a detailed prediction of the <sup>1</sup>H NMR spectrum. The analysis is broken down by proton type.

### Aromatic Protons (H-3 and H-5)

- H-3 Proton: This proton is positioned ortho to both the strongly electron-withdrawing nitro group and the iodo group. It is also meta to the bromo and methoxy groups. The powerful deshielding effect of the adjacent nitro group will be the dominant factor, shifting this proton's signal significantly downfield.[6][7]
- H-5 Proton: This proton is situated ortho to the electron-donating methoxy group and the bromo group. It is meta to the nitro and iodo groups. While the methoxy group attempts to shield this proton, the combined inductive withdrawing effects of the three halogen and nitro substituents will result in a net deshielding. However, its downfield shift is expected to be less pronounced than that of H-3, which is directly ortho to the nitro group.

### Methoxy Protons (-OCH<sub>3</sub>)

- The three protons of the methoxy group are equivalent and have no adjacent protons. Therefore, they will appear as a sharp singlet in the spectrum. The precise chemical shift will be influenced by the overall electronic nature of the heavily substituted, electron-poor aromatic ring.

## Spin-Spin Coupling

- The two aromatic protons, H-3 and H-5, are separated by four bonds (meta to each other). This arrangement leads to meta-coupling ( $^4J$ ).<sup>[11]</sup> Meta coupling constants ( $^4J_{H,H}$ ) in benzene rings are typically small, in the range of 2-3 Hz.<sup>[12]</sup>
- Consequently, the signal for H-3 is expected to be a doublet, split by H-5, and the signal for H-5 will be a doublet, split by H-3, with both doublets exhibiting the same small coupling constant.

## Predicted Data Summary

The following table consolidates our predictions for the  $^1\text{H}$  NMR spectrum of **4-bromo-2-iodo-6-nitroanisole**, assuming acquisition in a standard solvent like  $\text{CDCl}_3$ .

Proton Assignment	Predicted Chemical Shift ( $\delta$ , ppm)	Predicted Multiplicity	Predicted Coupling Constant (J, Hz)	Integration
H-3	8.2 - 8.6	Doublet (d)	~2-3	1H
H-5	7.5 - 7.9	Doublet (d)	~2-3	1H
-OCH <sub>3</sub>	3.9 - 4.1	Singlet (s)	N/A	3H

Note: These are estimated values. The actual chemical shifts can vary depending on the solvent and spectrometer frequency.

## Part 3: Experimental Protocol for Spectrum Acquisition

A self-validating protocol is essential for acquiring high-quality, reproducible NMR data. The following steps outline a robust methodology.

## Step 1: Sample Preparation

- **Mass Measurement:** Accurately weigh approximately 5-10 mg of **4-bromo-2-iodo-6-nitroanisole**.
- **Solvent Selection:** Choose a suitable deuterated solvent in which the compound is soluble. Chloroform-d ( $\text{CDCl}_3$ ) is a common first choice. If solubility is an issue, dimethyl sulfoxide-d<sub>6</sub> (DMSO-d<sub>6</sub>) or acetone-d<sub>6</sub> can be used.
- **Dissolution:** Dissolve the sample in approximately 0.6-0.7 mL of the deuterated solvent in a clean vial.
- **Internal Standard:** Add a small amount of tetramethylsilane (TMS) as an internal reference ( $\delta = 0.00$  ppm).
- **Transfer:** Using a Pasteur pipette with a small cotton or glass wool plug, filter the solution directly into a clean, dry 5 mm NMR tube to remove any particulate matter.[\[13\]](#)
- **Capping:** Securely cap the NMR tube.

## Step 2: NMR Spectrometer Setup and Data Acquisition

- **Instrumentation:** Utilize a high-resolution NMR spectrometer, typically with a field strength of 400 MHz or higher for better signal dispersion.
- **Tuning and Shimming:** Insert the sample into the spectrometer. Tune the probe to the correct frequency and perform automated or manual shimming to optimize the magnetic field homogeneity.
- **Acquisition Parameters:**
  - **Experiment:** Select a standard 1D proton experiment (e.g., 'zg30').
  - **Spectral Width:** Set a spectral width of approximately 12-16 ppm to ensure all signals are captured.

- Transmitter Offset: Center the transmitter frequency in the middle of the expected spectral region (e.g., ~6 ppm).
- Number of Scans: Acquire a sufficient number of scans (e.g., 16 or 32) to achieve an adequate signal-to-noise ratio.
- Relaxation Delay (d1): Use a relaxation delay of 1-2 seconds.
- Acquisition Time (aq): Set an acquisition time of 2-4 seconds.

## Part 4: Data Processing and Interpretation Workflow

The logical flow from raw data to final interpretation is critical for accurate structural confirmation.

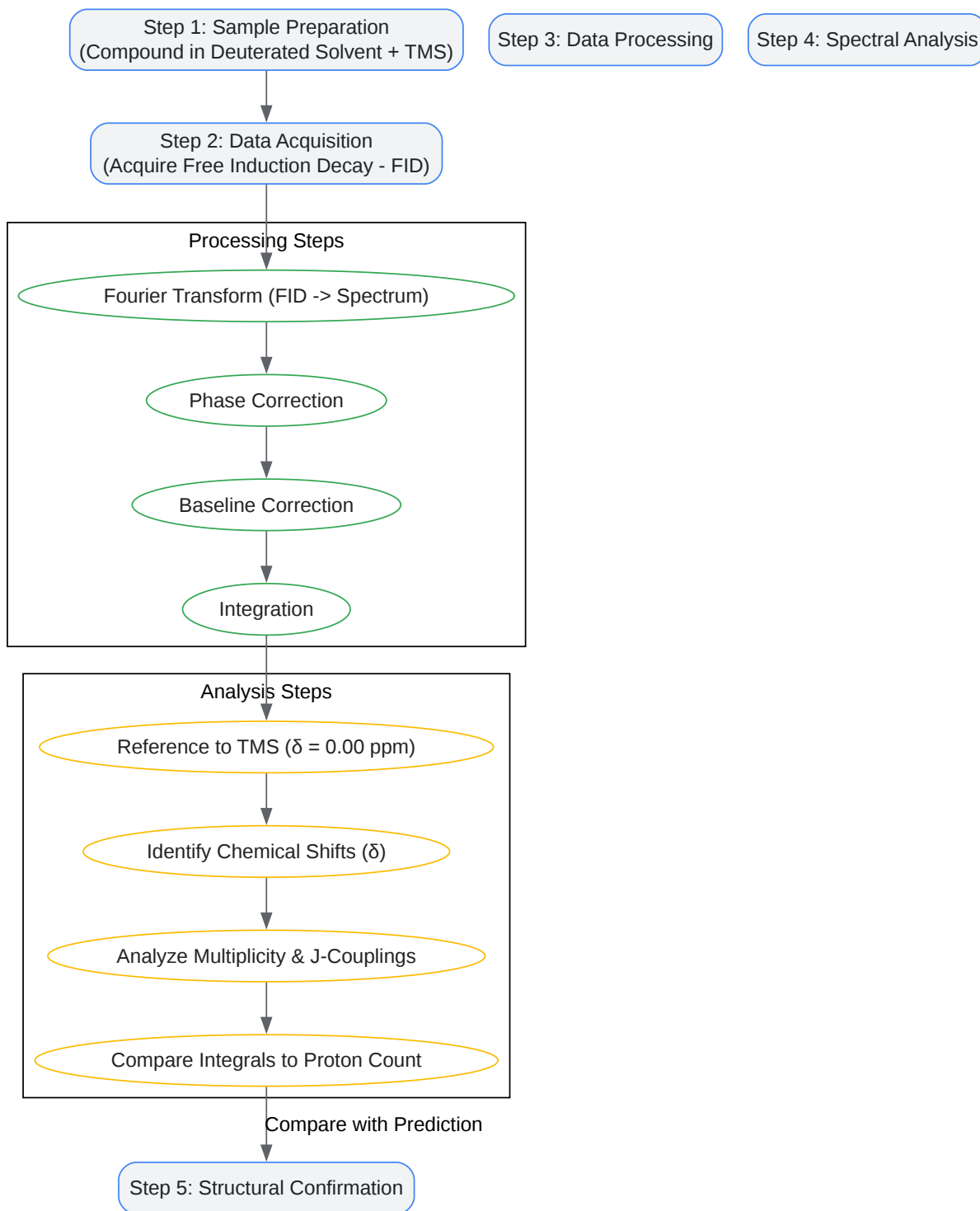

[Click to download full resolution via product page](#)

### Need Custom Synthesis?

BenchChem offers custom synthesis for rare earth carbides and specific isotopic labeling.

Email: [info@benchchem.com](mailto:info@benchchem.com) or [Request Quote Online](#).

## Sources

- [1. Accurate Prediction of <sup>1</sup>H NMR Chemical Shifts of Small Molecules Using Machine Learning - PMC \[pmc.ncbi.nlm.nih.gov\]](#)
- [2. nbinno.com \[nbinno.com\]](#)
- [3. epgp.inflibnet.ac.in \[epgp.inflibnet.ac.in\]](#)
- [4. The nitro group directs electrophilic aromatic substitution to th... | Study Prep in Pearson+ \[pearson.com\]](#)
- [5. researchgate.net \[researchgate.net\]](#)
- [6. organicchemistrydata.org \[organicchemistrydata.org\]](#)
- [7. orgchemboulder.com \[orgchemboulder.com\]](#)
- [8. modgraph.co.uk \[modgraph.co.uk\]](#)
- [9. Proton chemical shifts in NMR. Part 10.1 Bromine and iodine substituent chemical shifts \(SCS\) and an analysis of the contributions to the SCS in halocyclohexanes - Journal of the Chemical Society, Perkin Transactions 2 \(RSC Publishing\) \[pubs.rsc.org\]](#)
- [10. repository.ubn.ru.nl \[repository.ubn.ru.nl\]](#)
- [11. orgchemboulder.com \[orgchemboulder.com\]](#)
- [12. www2.chem.wisc.edu \[www2.chem.wisc.edu\]](#)
- [13. pdf.benchchem.com \[pdf.benchchem.com\]](#)
- To cite this document: BenchChem. [Introduction: Deciphering Complexity in Molecular Architecture]. BenchChem, [2026]. [Online PDF]. Available at: [\[https://www.benchchem.com/product/b2579974/docs#introduction-deciphering-complexity-in-molecular-architecture\]](https://www.benchchem.com/product/b2579974/docs#introduction-deciphering-complexity-in-molecular-architecture)

---

### Disclaimer & Data Validity:

The information provided in this document is for Research Use Only (RUO) and is strictly not intended for diagnostic or therapeutic procedures. While BenchChem strives to provide accurate protocols, we make no warranties, express or implied, regarding the fitness of this product for every specific experimental setup.

**Technical Support:** The protocols provided are for reference purposes. Unsure if this reagent suits your experiment?

**Need Industrial/Bulk Grade?** [Request Custom Synthesis Quote](#)

## BenchChem

Our mission is to be the trusted global source of essential and advanced chemicals, empowering scientists and researchers to drive progress in science and industry.

### Contact

Address: 3281 E Guasti Rd  
Ontario, CA 91761, United States  
Phone: (601) 213-4426  
Email: [info@benchchem.com](mailto:info@benchchem.com)

[Contact our Ph.D. Support Team for a compatibility check](#)