

Technical Guide: Mass Spectrometry Fragmentation of 2-Mercaptoquinoline-4- carboxamide

Author: BenchChem Technical Support Team. **Date:** May 2026

Compound of Interest

Compound Name:	2-Mercaptoquinoline-4- carboxamide
CAS No.:	929973-05-7
Cat. No.:	B2571054

[Get Quote](#)

Executive Summary

This guide details the electrospray ionization (ESI) and collision-induced dissociation (CID) behavior of **2-Mercaptoquinoline-4-carboxamide** (MW: 204.25 Da). Accurately characterizing this molecule requires distinguishing it from its common metabolic product, 2-Hydroxyquinoline-4-carboxamide (Carbostyryl derivative), and its synthetic precursor, 2-Chloroquinoline-4-carboxamide.

Key Differentiator: The defining mass spectrometric signature of the target molecule is the loss of carbon monosulfide (CS, 44 Da) from the quinoline core, contrasting with the loss of carbon monoxide (CO, 28 Da) observed in oxygenated analogs. This "Sulfur Shift" is critical for validating the integrity of the thioamide/thiol moiety during drug stability studies.

Physicochemical & Ionization Profile

Before interpreting spectra, the ionization behavior must be understood in the context of the molecule's tautomerism.

Property	Value	MS Implication
Formula	C ₁₀ H ₈ N ₂ OS	Monoisotopic Mass: 204.0357
Parent Ion	[M+H] ⁺ = 205.0430	Base peak in ESI(+) mode.
Tautomerism	Thiol (-SH) ⇌ Thione (=S)	Predominantly exists as the thione (2-quinolinethione) in solution/gas phase, affecting fragmentation energy.
pKa (calc)	~8.5 (Thiol), ~13 (Amide)	Readily protonates on the quinoline nitrogen or amide oxygen.

Fragmentation Mechanism & Pathways[1][2][3][4][5][6][7][8]

The fragmentation of **2-Mercaptoquinoline-4-carboxamide** follows a logic-gated pathway governed by the stability of the aromatic core and the lability of the carboxamide side chain.

Phase I: Amide Degradation (The "Gateway" Losses)

Upon collision (CID 15–25 eV), the carboxamide group at position 4 is the first to fragment.

- Loss of Ammonia (-17 Da): The primary amide undergoes cleavage to form an acylium ion.
 - Transition:m/z 205 → 188
- Loss of Carbon Monoxide (-28 Da): The resulting acylium ion rapidly decarbonylates.
 - Transition:m/z 188 → 160
 - Result: This generates the 2-mercaptoquinolin-4-yl cation (m/z 160/161), the core scaffold.

Phase II: The Thione Core Collapse (The "Fingerprint" Region)

High-energy collisions (CID >35 eV) force the destruction of the heterocyclic ring. This is where the specific sulfur signature appears.

- Loss of CS (-44 Da): Unlike oxygenated quinolines which lose CO, the 2-mercapto (thione) variant ejects a CS neutral fragment. This typically involves a ring contraction to an indole-like radical cation.
 - Transition: m/z 160 \rightarrow 116 (or 161 \rightarrow 117 depending on H-rearrangement).
- Loss of HCN (-27 Da): A universal feature of quinolines, representing the cleavage of the pyridine ring.
 - Transition: m/z 117 \rightarrow 90

Pathway Visualization

The following diagram illustrates the branching fragmentation logic.

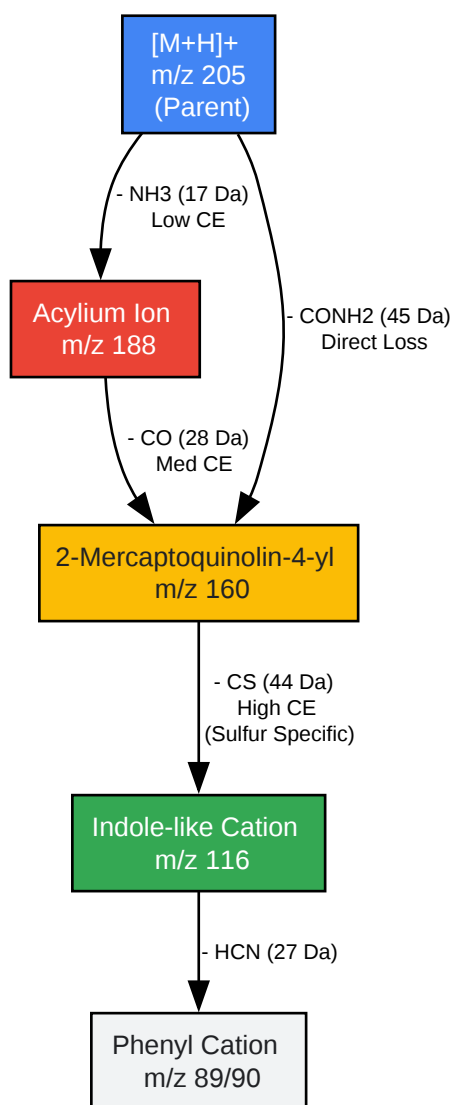

[Click to download full resolution via product page](#)

Figure 1: Proposed ESI-MS/MS fragmentation pathway for **2-Mercaptoquinoline-4-carboxamide**. The loss of CS (44 Da) is the diagnostic step distinguishing it from oxo-analogs.

Comparative Analysis: Target vs. Alternatives

In drug development, this compound is often compared against its 2-Hydroxy analog (a common metabolite) and Quinoline-4-carboxamide (the unsubstituted scaffold).

Feature	2-Mercapto- (Target)	2-Hydroxy- (Metabolite)	Unsubstituted (Scaffold)
Parent Ion [M+H] ⁺	205	189	173
Primary Loss	-NH ₃ (17) → m/z 188	-NH ₃ (17) → m/z 172	-NH ₃ (17) → m/z 156
Core Scaffold Ion	m/z 160 (Thio-carbostyryl)	m/z 144 (Carbostyryl)	m/z 128 (Quinoline)
Ring Contraction	Loss of CS (-44)	Loss of CO (-28)	Loss of HCN (-27)
Diagnostic Fragment	m/z 116 (Indole cation)	m/z 116 (Indole cation)	m/z 101
Differentiation	ΔMass = 44 (CS)	ΔMass = 28 (CO)	No heteroatom loss

Critical Insight: Both the Mercapto and Hydroxy analogs eventually collapse to the same indole-like fragment (m/z 116/117). The differentiation lies in the neutral loss leading to that fragment. You must monitor the transition (160 → 116 vs 144 → 116), not just the final ion.

Experimental Protocol (Self-Validating)

To reproduce these data and validate the identity of your compound, follow this LC-MS/MS workflow.

A. Sample Preparation

- Stock: Dissolve 1 mg of **2-Mercaptoquinoline-4-carboxamide** in 1 mL DMSO.
- Working Solution: Dilute to 1 μg/mL in 50:50 Acetonitrile:Water + 0.1% Formic Acid.
 - Note: Avoid high pH; basic conditions promote oxidation of the thiol to the disulfide dimer ([2M+H]⁺ ≈ 407).

B. MS Parameters (ESI+)

- Instrument: Triple Quadrupole (QqQ) or Q-TOF.
- Source Temp: 350°C (Ensure complete desolvation to prevent adducts).

- Capillary Voltage: 3.5 kV.
- Collision Energy (CE) Ramp:
 - Screening: 10–50 eV.
 - Optimal Fragmentation: 25 eV for Amide loss; 40 eV for CS loss.

C. Validation Criteria

The identification is confirmed only if:

- Parent ion is 205.0 ± 0.1 .
- Daughter ion 188.0 (Amide loss) appears at low CE.
- Neutral loss of 44 Da (CS) is observed from the core ion (160 → 116) at high CE.
 - Failure Mode: If you observe a loss of 32 Da (S) or 34 Da (H₂S), the molecule may be degrading thermally in the source rather than fragmenting via CID.

References

- Fragmentation of Quinoline Carboxamides: Leško, J., & Lásiková, A. (2000). Mass Spectra of Some 2-Substituted Derivatives of Quinoline-4-carboxylic Acids and their Amides. *Chemical Papers*, 54(2), 75-77.[1] [Link](#)
- Thione/Thiol Tautomerism in MS: Yuchi, A., et al. (1987). Equilibrium Studies on the Species Formed in the Extraction of Divalent Transition Metal Ions with 8-Quinolinethiol and Its 2-Methyl Derivative. *Bulletin of the Chemical Society of Japan*, 60(12), 4291-4297. [Link](#)
- General Quinoline Fragmentation: Clugston, D. M., & MacLean, D. B. (1966). Mass Spectra of Oxygenated Quinolines. *Canadian Journal of Chemistry*, 44, 781-788. [Link](#)
- CS Loss Mechanisms: Porter, Q. N. (1985). *Mass Spectrometry of Heterocyclic Compounds*. John Wiley & Sons. (General Reference for Thione CS loss).

Need Custom Synthesis?

BenchChem offers custom synthesis for rare earth carbides and specific isotopic labeling.

Email: info@benchchem.com or [Request Quote Online](#).

Sources

- 1. [researchgate.net](https://www.researchgate.net) [[researchgate.net](https://www.researchgate.net)]
- To cite this document: BenchChem. [Technical Guide: Mass Spectrometry Fragmentation of 2-Mercaptoquinoline-4-carboxamide]. BenchChem, [2026]. [Online PDF]. Available at: [<https://www.benchchem.com/product/b2571054/docs#technical-guide-mass-spectrometry-fragmentation-of-2-mercaptoquinoline-4-carboxamide>]

Disclaimer & Data Validity:

The information provided in this document is for Research Use Only (RUO) and is strictly not intended for diagnostic or therapeutic procedures. While BenchChem strives to provide accurate protocols, we make no warranties, express or implied, regarding the fitness of this product for every specific experimental setup.

Technical Support: The protocols provided are for reference purposes. Unsure if this reagent suits your experiment?

Need Industrial/Bulk Grade? [Request Custom Synthesis Quote](#)

BenchChem

Our mission is to be the trusted global source of essential and advanced chemicals, empowering scientists and researchers to drive progress in science and industry.

Contact

Address: 3281 E Guasti Rd

Ontario, CA 91761, United States

Phone: (601) 213-4426

Email: info@benchchem.com

Contact our Ph.D. Support Team for a compatibility check