

# Common pitfalls in the synthesis of morpholine-containing compounds.

**Author:** BenchChem Technical Support Team. **Date:** May 2026

## Compound of Interest

Compound Name: *2-Amino-4-morpholinobutanoic acid*

CAS No.: *770684-35-0*

Cat. No.: *B2571061*

[Get Quote](#)

## Technical Support Center: Morpholine Synthesis & Functionalization

Status: Operational | Tier: Level 3 (Senior Scientist Support) Ticket Subject: Troubleshooting Common Pitfalls in Morpholine Scaffold Synthesis

### User Guide Overview

Welcome to the Morpholine Synthesis Support Center. Morpholine is a privileged pharmacophore due to its ability to improve solubility and metabolic stability in drug candidates. However, its secondary amine nature and high polarity (

) introduce specific synthetic and isolation challenges.

This guide is structured into four troubleshooting modules designed to resolve specific failure modes in your workflow.

## Module 1: Nucleophilic Substitution ( )

Issue: "I am observing significant quaternary ammonium salt formation or low conversion."

### Root Cause Analysis

Morpholine is a moderate nucleophile (

). In standard alkylation, the product (tertiary amine) is often more nucleophilic than the starting morpholine, leading to over-alkylation (quaternization). In

reactions with electron-deficient aryl halides, the issue is often competitive hydrolysis or lack of reactivity.

### Troubleshooting Protocol

Symptom	Diagnosis	Corrective Action
Quaternary Salt (Spot on baseline of TLC)	Over-alkylation	1. Use slow addition of the electrophile to a dilute solution of morpholine.2. Switch to Reductive Amination (See Module 3) if the electrophile is an alkyl halide derived from an alcohol.3. Use a 3-5x molar excess of morpholine if the reagent is cheap; this statistically favors mono-alkylation.
Elimination Product (Alkene)	Basicity vs. Nucleophilicity	Morpholine is acting as a base. [1] Switch solvent to a non-polar aprotic solvent (e.g., Toluene) to destabilize the transition state for elimination, or lower the temperature.
Low Conversion ( )	Poor Electrophilicity	Ensure the aryl halide has an EWG (electron-withdrawing group) in the ortho or para position. If not, switch to Buchwald-Hartwig (Module 2).

## Visualization: The Alkylation Decision Tree

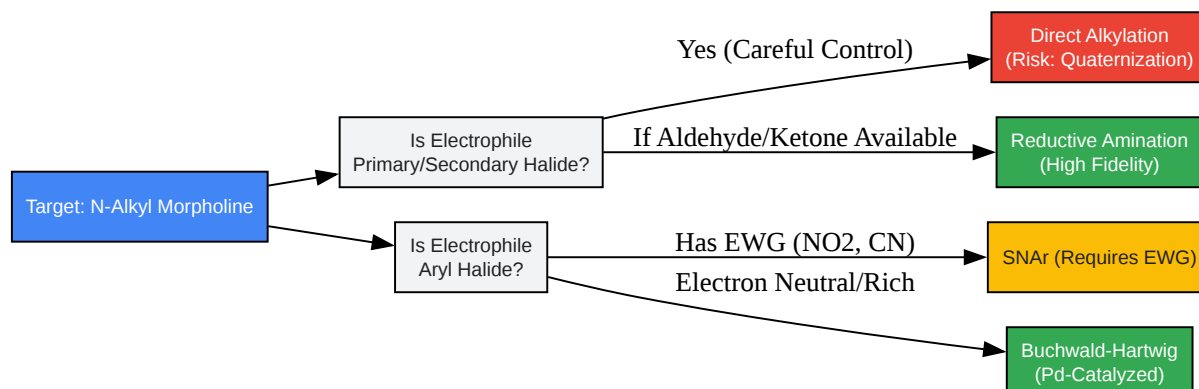

[Click to download full resolution via product page](#)

Caption: Decision logic to avoid quaternization and reactivity dead-ends.

## Module 2: Buchwald-Hartwig Amination

Issue: "Reaction turns black (Pd precipitation) and conversion stalls."

### Technical Insight

Morpholine is a secondary cyclic amine. While less sterically hindered than acyclic amines, it can poison palladium catalysts if the reductive elimination step is slow. The "Pd-black" indicates the catalyst has fallen out of the cycle (ligand dissociation).

### Critical Parameters

- Ligand Selection: Avoid simple phosphines ( ). Use bulky, electron-rich dialkylbiaryl phosphines like RuPhos or XPhos. RuPhos is particularly effective for secondary amines like morpholine [1].
- Base Effect: Strong bases like can cause dehalogenation of the aryl halide (reduction side product) rather than coupling. If observing dehalogenated starting material, switch to a weaker base like or

## Standardized Protocol (Self-Validating)

- Checkpoint 1: Charge flask with (1 mol%) and RuPhos (2 mol%). Add solvent (Dioxane or Toluene) and stir at elevated temp (60°C) for 5 mins before adding reactants.
  - Validation: Solution should turn a clear deep red/orange (active catalyst formation). If black immediately, solvents are wet.
- Add Aryl Halide (1.0 equiv), Morpholine (1.2 equiv), and (1.4 equiv).
- Stir at 80-100°C.
- Checkpoint 2: Monitor by LCMS. If Ar-H (dehalogenation) appears >10%, lower temp or switch base to

## Module 3: Reductive Amination

Issue: "Incomplete conversion or formation of alcohol side products."

### Mechanism & Causality

This is often the most reliable method for attaching morpholine to alkyl chains. The reaction proceeds via an iminium ion intermediate.<sup>[1][2]</sup>

- Pitfall: Using Sodium Cyanoborohydride ( ) at the wrong pH. It requires pH 6-7 to be effective.<sup>[2]</sup>
- Solution: Use Sodium Triacetoxyborohydride (STAB).<sup>[3][4]</sup> It is less toxic and works without strict pH monitoring in DCE or THF <sup>[2]</sup>.

### Optimized Workflow

- Mix Carbonyl (1.0 equiv) and Morpholine (1.1 equiv) in DCE (1,2-Dichloroethane).
- Add Acetic Acid (1.0 equiv). Why? Catalyzes iminium formation.
- Add STAB (1.4 equiv) after 15-30 minutes of stirring.
  - Note: Adding STAB immediately can lead to direct reduction of the ketone/aldehyde to an alcohol before the imine forms.
- Quench with saturated [NaOH](#) solution.

[4]

## Module 4: Isolation & Purification (The Hidden Trap)

Issue: "My product disappeared during the aqueous workup."

### The Solubility Paradox

Morpholine derivatives are often highly polar. In a standard EtOAc/Water extraction, a significant portion of the product may remain in the aqueous phase, especially if the pH is not basic enough to suppress the ammonium form.

### Purification Troubleshooting Table

Method	Protocol	When to Use
Salting Out	Saturate the aqueous phase with NaCl. Extract with CHCl <sub>3</sub> :IPA (3:1) instead of EtOAc.	Product is highly water-soluble ( ).
SCX Column	Load reaction mixture (in MeOH) onto a Strong Cation Exchange (SCX) cartridge. Wash with MeOH (removes non-basic impurities). Elute with in MeOH.	Removing non-basic impurities without aqueous workup.
Distillation	Warning: Morpholine forms an azeotrope with water.[5] Use toluene to azeotropically dry the mixture before attempting vacuum distillation.	Volatile morpholine derivatives.

## Visualizing the Extraction Problem

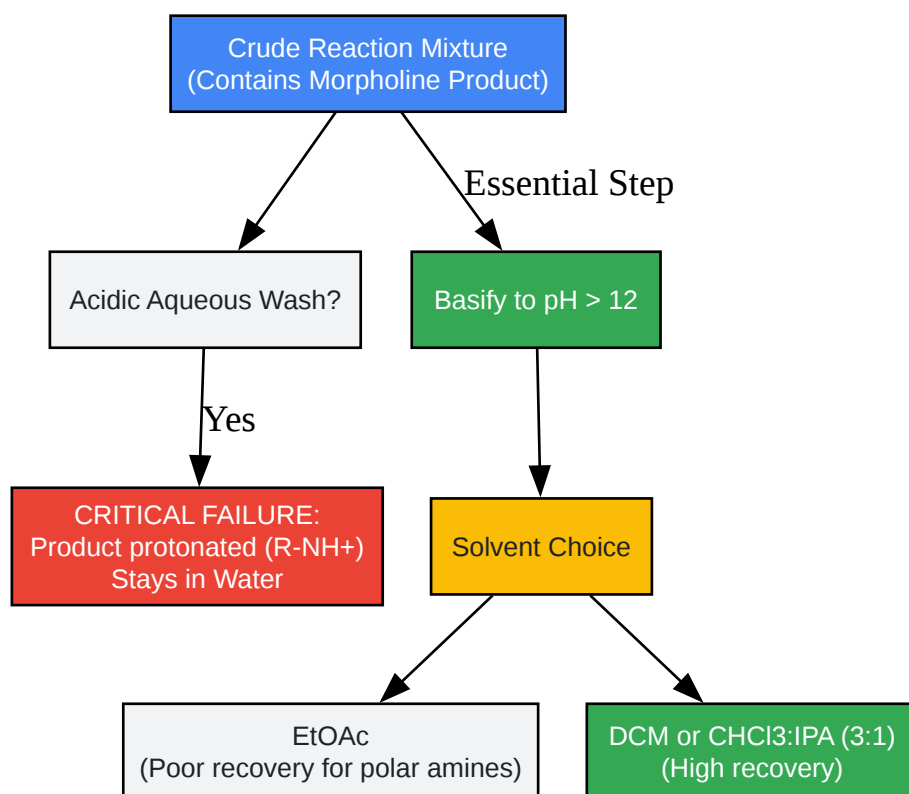

[Click to download full resolution via product page](#)

Caption: Extraction logic flow to prevent product loss in aqueous phase.

## References

- Buchwald, S. L., et al. "RuPhos: A Privileged Ligand for Pd-Catalyzed C-N Cross-Coupling Reactions." *Journal of the American Chemical Society*, 2008.[6]
- Abdel-Magid, A. F., et al. "Reductive Amination of Aldehydes and Ketones with Sodium Triacetoxyborohydride." *The Journal of Organic Chemistry*, 1996.[2]
- Pfizer Process Development. "Synthesis of Linezolid: Process Safety and Scale-up." *Organic Process Research & Development*. (Demonstrates industrial morpholine handling).

### Need Custom Synthesis?

BenchChem offers custom synthesis for rare earth carbides and specific isotopic labeling.

Email: [info@benchchem.com](mailto:info@benchchem.com) or [Request Quote Online](#).

## Sources

- [1. chemistry.mdma.ch \[chemistry.mdma.ch\]](https://chemistry.mdma.ch)
- [2. myers.faculty.chemistry.harvard.edu \[myers.faculty.chemistry.harvard.edu\]](https://myers.faculty.chemistry.harvard.edu)
- [3. Reductive Amination - Common Conditions \[commonorganicchemistry.com\]](https://commonorganicchemistry.com)
- [4. pdf.benchchem.com \[pdf.benchchem.com\]](https://pdf.benchchem.com)
- [5. patentimages.storage.googleapis.com \[patentimages.storage.googleapis.com\]](https://patentimages.storage.googleapis.com)
- [6. WO2011077310A1 - Process for the preparation of linezolid - Google Patents \[patents.google.com\]](https://patents.google.com)
- To cite this document: BenchChem. [Common pitfalls in the synthesis of morpholine-containing compounds.]. BenchChem, [2026]. [Online PDF]. Available at: [\[https://www.benchchem.com/product/b2571061/docs#common-pitfalls-in-the-synthesis-of-morpholine-containing-compounds\]](https://www.benchchem.com/product/b2571061/docs#common-pitfalls-in-the-synthesis-of-morpholine-containing-compounds)

---

### Disclaimer & Data Validity:

The information provided in this document is for Research Use Only (RUO) and is strictly not intended for diagnostic or therapeutic procedures. While BenchChem strives to provide accurate protocols, we make no warranties, express or implied, regarding the fitness of this product for every specific experimental setup.

**Technical Support:** The protocols provided are for reference purposes. Unsure if this reagent suits your experiment?

**Need Industrial/Bulk Grade?** [Request Custom Synthesis Quote](#)

## BenchChem

Our mission is to be the trusted global source of essential and advanced chemicals, empowering scientists and researchers to drive progress in science and industry.

### Contact

Address: 3281 E Guasti Rd

Ontario, CA 91761, United States

Phone: (601) 213-4426

Email: [info@benchchem.com](mailto:info@benchchem.com)

Contact our Ph.D. Support Team for a compatibility check