

# Technical Support Center: Preventing Oxetane Ring Opening During Acidic Workup

**Author:** BenchChem Technical Support Team. **Date:** April 2026

## Compound of Interest

Compound Name: 4-(Oxetan-3-yloxy)benzotrile

CAS No.: 1349716-20-6

Cat. No.: B3027607

[Get Quote](#)

Welcome to the Technical Support Center. As oxetanes become increasingly ubiquitous in medicinal chemistry as liponeutral bioisosteres for carbonyls and gem-dimethyl groups, handling their unique reactivity profile is critical. While they offer improved metabolic stability, aqueous solubility, and reduced amine basicity, their inherent ring strain (~107 kJ/mol) makes them susceptible to acid-catalyzed ring opening[1],[2].

This guide provides mechanistic troubleshooting, quantitative stability data, and field-validated protocols to preserve oxetane integrity during downstream processing and acidic workups.

## Understanding the Mechanism of Degradation

Q: Why do my oxetanes degrade during standard acidic workups?

A: The degradation is driven by thermodynamics and initiated by protonation. When an oxetane is exposed to strong aqueous acids (e.g., 1M HCl or H<sub>2</sub>SO<sub>4</sub>), the ring oxygen is protonated, forming a highly electrophilic oxonium ion. The release of ring strain provides a strong thermodynamic driving force for nucleophilic attack by water or halides, leading to the formation of 1,3-diols or 1,3-halohydrins[3].

However, the categorical instability of oxetanes to acid is a misconception; stability is highly dependent on the substitution pattern. 3,3-disubstituted oxetanes are significantly more stable because the substituents sterically block the trajectory of external nucleophiles from attacking the C–O  $\sigma^*$  antibonding orbital<sup>[1]</sup>.

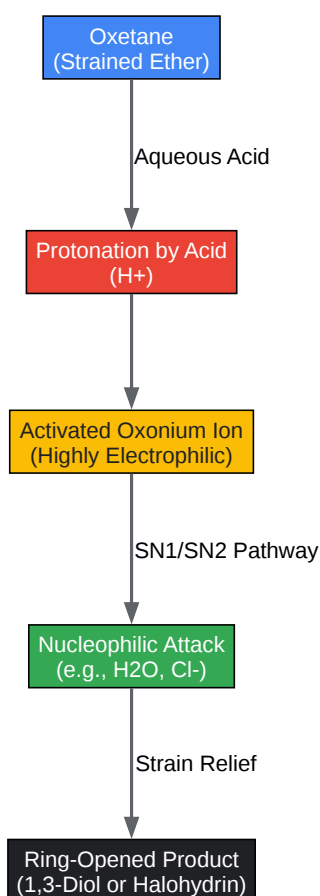

[Click to download full resolution via product page](#)

Mechanism of acid-catalyzed oxetane ring opening.

## Quantitative Stability Profiles

Q: How does substitution affect oxetane stability across different pH levels?

A: The substitution pattern is the primary determinant of chemical stability. Unsubstituted or mono-substituted oxetanes are highly vulnerable, whereas 3,3-disubstituted oxetanes can withstand surprisingly harsh conditions, even down to pH 1.2[2]. Caution: If the oxetane contains an internal nucleophile (e.g., a proximal alcohol or amine), it may undergo rapid intramolecular ring-opening under acidic conditions regardless of the external substitution[1].

**Table 1: Comparative Stability of Heterocycles in Acidic Conditions[2]**

Heterocycle	Substitution Pattern	Test Conditions	Stability Outcome
Oxetane	3,3-Diaryl	pH 1.2	>80% remaining after 24 hours
Oxetane	2-Sulfonyl	pH 1–10, 25 °C	Half-life of 4–5 days
Oxetane	3-Aryl-3-alkoxy	1 M HCl, 37 °C	31% recovery after 24 hours
Epoxide	Unsubstituted	Dilute Aqueous Acid	Rapid hydrolysis to a 1,2-diol
Tetrahydrofuran	Unsubstituted	Strong Acid	Ring-opening can occur

## Troubleshooting Workup Workflows

Q: How should I quench a basic reaction containing an oxetane without triggering ring opening?

A: Avoid strong mineral acids entirely. Instead, utilize mild buffering systems. Saturated aqueous ammonium chloride (pH ~6) or 0.1 M phosphate buffers (pH 6–7) provide sufficient protons to neutralize alkoxides or amine bases without generating the highly acidic environment required to protonate the oxetane oxygen.

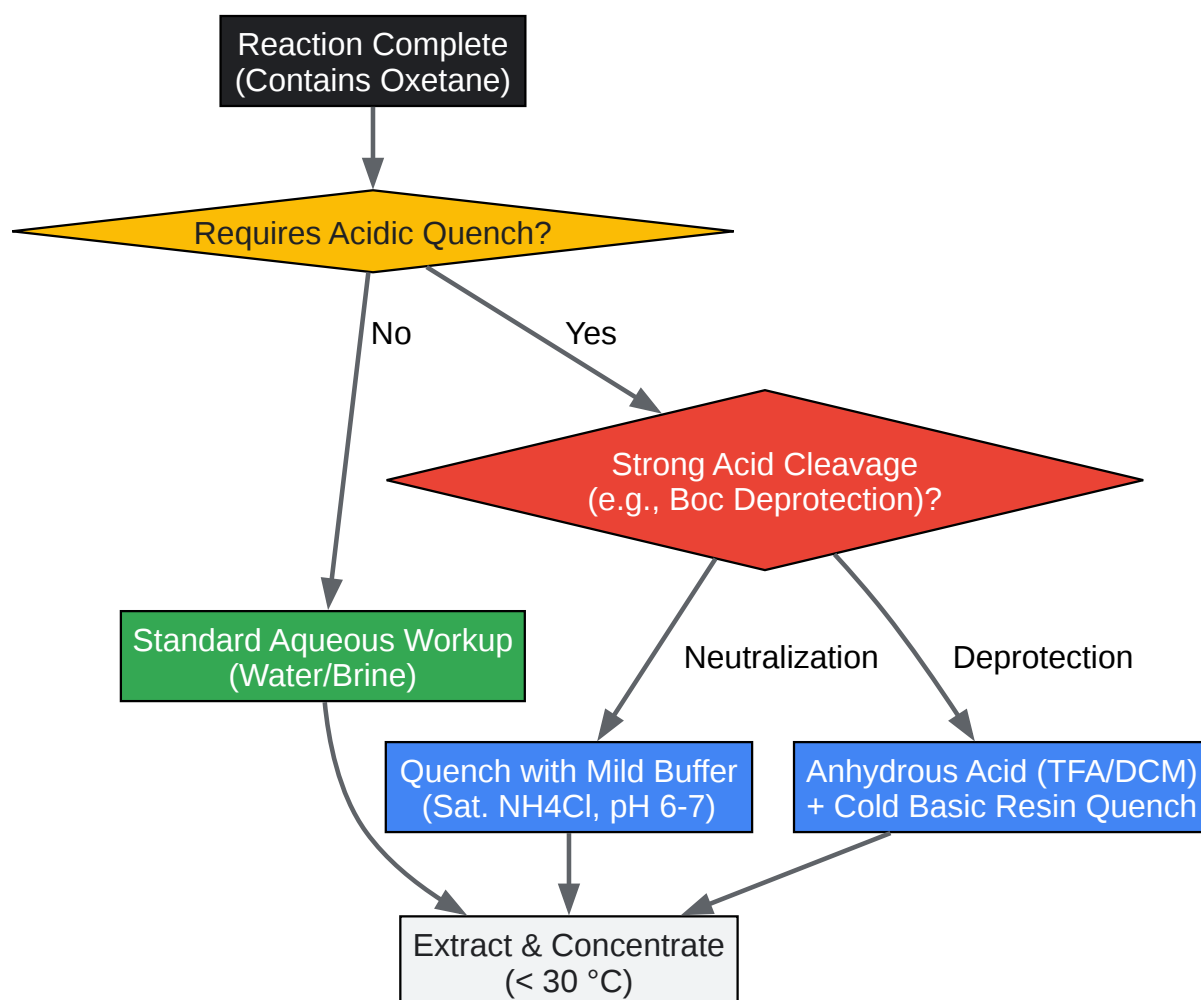

[Click to download full resolution via product page](#)

Workflow for selecting the appropriate oxetane workup strategy.

## Protocol 1: Mild Aqueous Workup for Oxetane-Containing Intermediates

Self-Validation Metric: Phase separation should be clean; emulsion formation indicates incomplete neutralization. Check aqueous pH with indicator paper (target pH 6-7) before discarding.

- Temperature Control: Cool the reaction mixture to 0 °C to minimize the kinetic energy available for side reactions.
- Dilution: Dilute the mixture with an organic solvent (e.g., EtOAc or DCM).
- Mild Quench: Slowly add saturated aqueous NH<sub>4</sub>Cl or a 0.1 M phosphate buffer (pH 7.0) dropwise. Do not use 1M HCl.
- Separation: Separate the layers and wash the organic layer with brine to remove residual water.
- Drying: Dry over anhydrous Na<sub>2</sub>SO<sub>4</sub>. (Note: Avoid MgSO<sub>4</sub> if the oxetane is highly sensitive, as Mg<sup>2+</sup> can act as a mild Lewis acid).
- Concentration: Concentrate under reduced pressure at a water bath temperature not exceeding 30 °C.

## Protecting Group Removal (Boc Deprotection)

Q: I need to remove a Boc protecting group from an oxetane-containing molecule. How can I do this without destroying the ring?

A: Boc deprotection requires strong acid, which seems incompatible with oxetanes. The solution is to use anhydrous acidic conditions (e.g., TFA in DCM) and, critically, to avoid aqueous acidic workup entirely<sup>[4],[5]</sup>. Water acts as a potent nucleophile once the oxetane is protonated. By using anhydrous TFA, you can successfully remove the Boc group without

degrading the oxetane<sup>[5]</sup>. To work up the reaction, you must neutralize the acid in situ using a non-nucleophilic basic resin at low temperatures before any water is introduced.

## Protocol 2: Anhydrous Boc Deprotection & Resin Quench

Self-Validation Metric: LCMS analysis before and after resin addition. The presence of the target mass (M+H) and absence of the ring-opened mass (M+H+18 for diol) validates the quench.

- **Reaction Setup:** Dissolve the N-Boc-oxetane substrate in anhydrous DCM (0.1 M) and cool to 0 °C under an inert atmosphere.
- **Acid Addition:** Add anhydrous Trifluoroacetic acid (TFA) dropwise (approx. 10–20 equivalents).
- **Deprotection:** Stir at 0 °C to room temperature until the starting material is consumed (monitor by TLC/LCMS).
- **Crucial Quench Step:** Do NOT add aqueous base. Cool the reaction back to 0 °C. Add a basic ion-exchange resin (e.g., Amberlyst A21) or finely powdered solid K<sub>2</sub>CO<sub>3</sub> in portions to neutralize the TFA in situ.
- **Validation:** Take a micro-aliquot, filter, and run an LCMS. The pH of the solution should be neutral to slightly basic.
- **Filtration:** Filter the suspension to remove the resin/salts. Wash the resin thoroughly with a polar aprotic solvent mixture (e.g., 10% MeOH in DCM) to ensure full recovery of the polar amine product.
- **Isolation:** Concentrate the filtrate under reduced pressure to yield the free amine without any aqueous acidic exposure.

## References

- <sup>[1]</sup> Title: Oxetanes in Drug Discovery Campaigns | Source: nih.gov | URL:

- [3] Title: Oxetanes: Recent Advances in Synthesis, Reactivity, and Medicinal Chemistry | Chemical Reviews | Source: [acs.org](https://acs.org) | URL:
- [4] Title: Oxetane as a part of modern medicinal chemistry toolbox: the case of 3,3-disubstituted building blocks | Source: [chemrxiv.org](https://chemrxiv.org) | URL:
- [2] Title: Assessing the stability of the oxetane ring under various chemical conditions | Source: [benchchem.com](https://benchchem.com) | URL:
- [5] Title: Synthesis of diversely functionalised 2,2-disubstituted oxetanes: fragment motifs in new chemical space | Source: [rsc.org](https://rsc.org) | URL:

### Need Custom Synthesis?

BenchChem offers custom synthesis for rare earth carbides and specific isotopic labeling.

Email: [info@benchchem.com](mailto:info@benchchem.com) or [Request Quote Online](#).

## Sources

- 1. Oxetanes in Drug Discovery Campaigns - PMC [[pmc.ncbi.nlm.nih.gov](https://pmc.ncbi.nlm.nih.gov)]
- 2. [pdf.benchchem.com](https://pdf.benchchem.com) [[pdf.benchchem.com](https://pdf.benchchem.com)]
- 3. [pubs.acs.org](https://pubs.acs.org) [[pubs.acs.org](https://pubs.acs.org)]
- 4. [chemrxiv.org](https://chemrxiv.org) [[chemrxiv.org](https://chemrxiv.org)]
- 5. Synthesis of diversely functionalised 2,2-disubstituted oxetanes: fragment motifs in new chemical space - Chemical Communications (RSC Publishing) DOI:10.1039/C5CC05740J [[pubs.rsc.org](https://pubs.rsc.org)]
- To cite this document: BenchChem. [Technical Support Center: Preventing Oxetane Ring Opening During Acidic Workup]. BenchChem, [2026]. [Online PDF]. Available at: [<https://www.benchchem.com/product/b3027607/docs#technical-support-center-preventing-oxetane-ring-opening-during-acidic-workup>]

---

### Disclaimer & Data Validity:

The information provided in this document is for Research Use Only (RUO) and is strictly not intended for diagnostic or therapeutic procedures. While BenchChem strives to provide

accurate protocols, we make no warranties, express or implied, regarding the fitness of this product for every specific experimental setup.

**Technical Support:** The protocols provided are for reference purposes. Unsure if this reagent suits your experiment?

**Need Industrial/Bulk Grade?** [Request Custom Synthesis Quote](#)

## BenchChem

Our mission is to be the trusted global source of essential and advanced chemicals, empowering scientists and researchers to drive progress in science and industry.

### Contact

Address: 3281 E Guasti Rd  
Ontario, CA 91761, United States  
Phone: (601) 213-4426  
Email: [info@benchchem.com](mailto:info@benchchem.com)

[Contact our Ph.D. Support Team for a compatibility check](#)