

# Technical Support Center: Enhancing Cell Permeability of Transglutaminase 2 (TG2) Inhibitors

**Author:** BenchChem Technical Support Team. **Date:** April 2026

## Compound of Interest

Compound Name: LDN-27219  
CAS No.: 312946-37-5  
Cat. No.: B2568743

[Get Quote](#)

This technical support center provides troubleshooting guidance and frequently asked questions (FAQs) for researchers, scientists, and drug development professionals encountering challenges with the cell permeability of **LDN-27219** derivatives and other transglutaminase 2 (TG2) inhibitors.

Disclaimer: While **LDN-27219** is often described as a lipophilic and cell-permeable compound, certain derivatives or specific experimental contexts may lead to observations of poor cell permeability.<sup>[1][2]</sup> This guide addresses these potential challenges more broadly for TG2 inhibitors.

## Frequently Asked Questions (FAQs)

**Q1:** My **LDN-27219** derivative shows high potency in biochemical assays but low efficacy in cell-based assays. Could this be a permeability issue?

**A1:** Yes, a significant drop in potency from a biochemical to a cell-based assay is a classic indicator of poor cell permeability. The compound may not be efficiently crossing the cell

membrane to reach its intracellular target, TG2. It is crucial to quantify the cell permeability of your compound to confirm this.

Q2: What are the key physicochemical properties that influence the cell permeability of small molecule inhibitors like **LDN-27219** derivatives?

A2: Several key physicochemical properties govern a compound's ability to cross the cell membrane, primarily through passive diffusion. These include:

- Lipophilicity (LogP): An optimal LogP (typically between 1 and 5) is required for good membrane permeability.
- Polar Surface Area (PSA): A lower PSA is generally preferred, as high polarity can hinder passage through the lipid bilayer.
- Molecular Weight (MW): Smaller molecules tend to diffuse more readily across the cell membrane.
- Hydrogen Bond Donors and Acceptors: A high number of hydrogen bond donors and acceptors can increase the energy barrier for a molecule to enter the hydrophobic membrane core.
- Solubility: Adequate aqueous solubility is necessary for the compound to be available at the cell surface to initiate permeation.

Q3: How can I experimentally measure the cell permeability of my **LDN-27219** derivative?

A3: The two most common in vitro methods for assessing cell permeability are the Caco-2 permeability assay and the Parallel Artificial Membrane Permeability Assay (PAMPA).

- Caco-2 Permeability Assay: This assay uses a monolayer of human colon adenocarcinoma cells (Caco-2) that differentiate to form tight junctions, mimicking the intestinal barrier.[3] It provides an apparent permeability coefficient (P<sub>app</sub>) and can also indicate if a compound is a substrate for efflux transporters like P-glycoprotein (P-gp).[4]
- PAMPA: This is a non-cell-based assay that measures a compound's ability to diffuse across an artificial lipid membrane.[5] It is a high-throughput method for assessing passive

permeability.

Q4: What is considered a "low" permeability value for a TG2 inhibitor?

A4: Permeability is context-dependent, but based on published data for other TG2 inhibitors, a Caco-2 Papp value of less than  $1 \times 10^{-6}$  cm/s is considered low. For instance, the TG2 inhibitor ZED1227 has a reported Caco-2 permeability of  $< 1 \times 10^{-6}$  cm/s.[6]

Q5: My compound has good passive permeability in the PAMPA assay but poor permeability in the Caco-2 assay. What does this suggest?

A5: This discrepancy often points towards active efflux. The Caco-2 cells express efflux transporters, such as P-glycoprotein (P-gp), which can actively pump the compound out of the cell, thereby reducing its net intracellular concentration. A bidirectional Caco-2 assay can confirm this by calculating the efflux ratio. An efflux ratio greater than 2 is a strong indicator of active efflux.[7]

## Troubleshooting Guides

### Issue 1: Low Apparent Permeability (Papp) in Caco-2 and PAMPA Assays

This suggests a fundamental issue with the compound's ability to passively diffuse across a lipid membrane.

Potential Cause	Troubleshooting Steps
Unfavorable Physicochemical Properties	<ul style="list-style-type: none"><li>- Review Physicochemical Data: Analyze the compound's LogP, PSA, MW, and hydrogen bonding capacity.</li><li>- Chemical Modification: Consider synthesizing analogs with increased lipophilicity (e.g., adding lipophilic groups) or reduced polarity (e.g., masking polar groups). For acyl hydrazide derivatives, modifications to the acyl or hydrazide portion can be explored.<sup>[8]</sup><sup>[9]</sup><sup>[10]</sup><sup>[11]</sup></li></ul>
Low Aqueous Solubility	<ul style="list-style-type: none"><li>- Solubility Assessment: Experimentally determine the aqueous solubility of the compound in the assay buffer.</li><li>- Formulation Strategies: For in vitro testing, consider using a co-solvent (e.g., DMSO, ensuring the final concentration does not affect membrane integrity) or formulating the compound with cyclodextrins to increase its solubility.</li></ul>
Compound Instability	<ul style="list-style-type: none"><li>- Stability Check: Assess the stability of the compound in the assay buffer over the time course of the experiment. Degradation can lead to an underestimation of permeability.</li></ul>

## Issue 2: High Efflux Ratio in Bidirectional Caco-2 Assay

This indicates that the compound is a substrate for active efflux transporters.

Potential Cause	Troubleshooting Steps
P-glycoprotein (P-gp) Substrate	<ul style="list-style-type: none"> <li>- Co-administration with Inhibitors: Perform the Caco-2 assay in the presence of a known P-gp inhibitor (e.g., verapamil). A significant increase in the A-to-B Papp value and a decrease in the efflux ratio would confirm that your compound is a P-gp substrate.[7]</li> <li>- Structural Modification: Modify the compound to reduce its affinity for P-gp. This can involve altering charge, hydrogen bonding capacity, or overall conformation.</li> </ul>
Substrate for Other Efflux Transporters (e.g., BCRP, MRPs)	<ul style="list-style-type: none"> <li>- Use of Specific Inhibitors: Test with inhibitors specific to other efflux transporters to identify the responsible pump.</li> </ul>

## Quantitative Data for TG2 Inhibitors

The following table summarizes permeability data for some reported TG2 inhibitors to provide a reference for experimental results.

Compound	Assay Type	Permeability (Papp in cm/s)	Efflux Ratio	Reference
ZED1227	Caco-2	$< 1 \times 10^{-6}$	Not Reported	[6]
Inhibitor 28	MDCK-MDR1	Good (with P-gp inhibitor)	15.5	[7]
Inhibitor 35 (JA38)	MDCK-MDR1	Excellent (with P-gp inhibitor)	Not specified, but susceptible to P-gp efflux	[7]
Cell-impermeable inhibitor 17	PAMPA	-Log Pe > 9.02 (negligible)	Not Applicable	[12][13]
Cell-impermeable inhibitor 18	PAMPA	-Log Pe > 8.79 (negligible)	Not Applicable	[12][13]

## Experimental Protocols

### Detailed Methodology for Caco-2 Permeability Assay

- Cell Culture:
  - Culture Caco-2 cells in a suitable medium (e.g., DMEM with 10% FBS, non-essential amino acids, and penicillin-streptomycin).
  - Seed cells onto permeable Transwell® inserts (e.g., 0.4 µm pore size) at a density of approximately  $6 \times 10^4$  cells/cm<sup>2</sup>.
  - Culture for 21-25 days to allow for differentiation and formation of a confluent monolayer with tight junctions.
- Monolayer Integrity Assessment:
  - Measure the Transepithelial Electrical Resistance (TEER) of the monolayer using a voltmeter. TEER values should be  $>200 \Omega \cdot \text{cm}^2$ .
  - Alternatively, assess the permeability of a low-permeability marker, such as Lucifer Yellow. The Papp for Lucifer Yellow should be  $<1.0 \times 10^{-6}$  cm/s.
- Permeability Assay (Apical to Basolateral - A to B):
  - Wash the Caco-2 monolayers with pre-warmed Hanks' Balanced Salt Solution (HBSS).
  - Add fresh HBSS to the basolateral (receiver) chamber.
  - Add the dosing solution of the test compound (e.g., 10 µM in HBSS) to the apical (donor) chamber.
  - Incubate at 37°C with gentle shaking for a defined period (e.g., 2 hours).
  - At the end of the incubation, collect samples from both the apical and basolateral chambers.
- Permeability Assay (Basolateral to Apical - B to A for Efflux):

- Follow the same procedure as above, but add the dosing solution to the basolateral chamber and sample from the apical chamber.
- Sample Analysis:
  - Analyze the concentration of the test compound in the collected samples using a suitable analytical method, such as LC-MS/MS.
- Data Analysis:
  - Calculate the apparent permeability coefficient ( $P_{app}$ ) using the following equation:  $P_{app} = (dQ/dt) / (A * C_0)$  Where:
    - $dQ/dt$  is the rate of permeation of the drug across the cells.
    - $A$  is the surface area of the permeable membrane.
    - $C_0$  is the initial concentration of the drug in the donor chamber.
  - Calculate the efflux ratio:  $\text{Efflux Ratio} = P_{app} (\text{B to A}) / P_{app} (\text{A to B})$

## Detailed Methodology for Parallel Artificial Membrane Permeability Assay (PAMPA)

- Plate Preparation:
  - Use a 96-well filter plate (donor plate) and a 96-well acceptor plate.
  - Coat the filter membrane of each well in the donor plate with a small volume (e.g., 5  $\mu\text{L}$ ) of a lipid solution (e.g., 1% lecithin in dodecane) and allow the solvent to evaporate.
- Assay Procedure:
  - Fill the wells of the acceptor plate with buffer (e.g., PBS at pH 7.4).
  - Add the dosing solution of the test compound (e.g., 10  $\mu\text{M}$  in buffer) to the wells of the donor plate.

- Carefully place the donor plate on top of the acceptor plate, ensuring the lipid-coated membrane is in contact with the acceptor buffer.
- Incubate the plate assembly at room temperature with gentle shaking for a defined period (e.g., 4-16 hours).
- Sample Analysis:
  - After incubation, separate the plates and determine the concentration of the test compound in both the donor and acceptor wells using an appropriate analytical method (e.g., LC-MS/MS or UV-Vis spectroscopy).
- Data Analysis:
  - Calculate the effective permeability ( $P_e$ ) using a suitable equation that takes into account the concentrations in the donor and acceptor wells, the incubation time, and the dimensions of the assay system.

## Visualizations

### TG2 Signaling Pathway

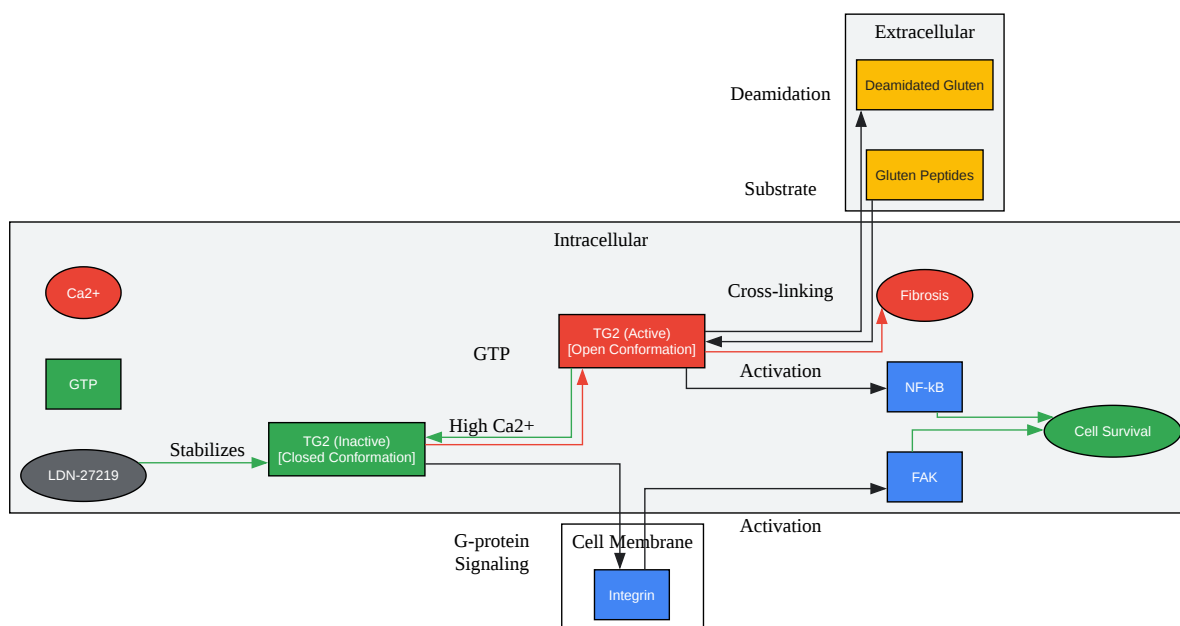

[Click to download full resolution via product page](#)

Caption: Simplified TG2 signaling pathway.

## Experimental Workflow for Assessing and Improving Cell Permeability

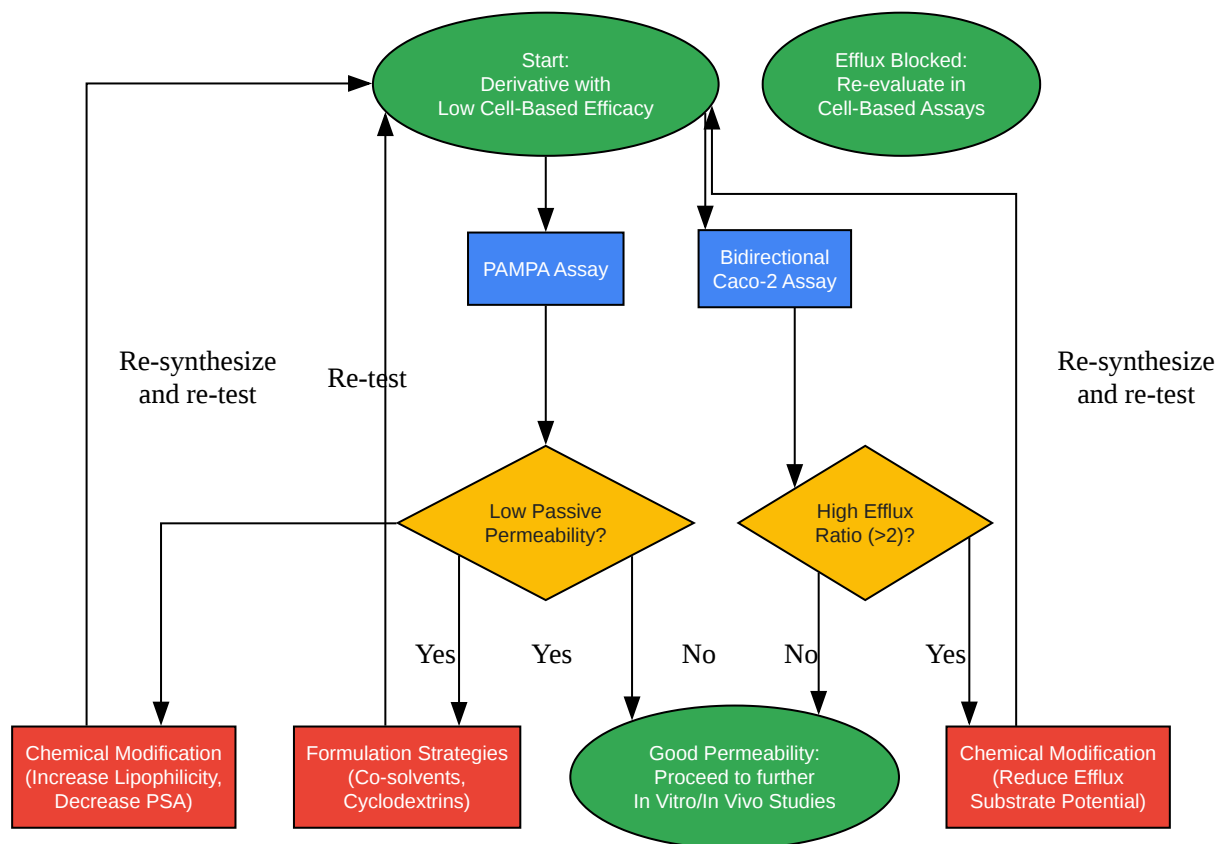

[Click to download full resolution via product page](#)

Caption: Workflow for permeability assessment.

### Need Custom Synthesis?

BenchChem offers custom synthesis for rare earth carbides and specific isotopic labeling.

Email: [info@benchchem.com](mailto:info@benchchem.com) or [Request Quote Online](#).

## References

- 1. Renal and Vascular Effects of the Allosteric Transglutaminase 2 Modulator LDN-27219 in One-Kidney DOCA–Salt Mice - PMC [[pmc.ncbi.nlm.nih.gov](https://pubmed.ncbi.nlm.nih.gov)]
- 2. Renal and Vascular Effects of the Allosteric Transglutaminase 2 Modulator LDN-27219 in One-Kidney DOCA–Salt Mice [[mdpi.com](https://mdpi.com)]
- 3. Caco-2 cell permeability assays to measure drug absorption - PubMed [[pubmed.ncbi.nlm.nih.gov](https://pubmed.ncbi.nlm.nih.gov)]
- 4. Optimization of the Caco-2 permeability assay to screen drug compounds for intestinal absorption and efflux - PubMed [[pubmed.ncbi.nlm.nih.gov](https://pubmed.ncbi.nlm.nih.gov)]
- 5. PAMPA | Evotec [[evotec.com](https://evotec.com)]
- 6. Features of ZED1227: The First-In-Class Tissue Transglutaminase Inhibitor Undergoing Clinical Evaluation for the Treatment of Celiac Disease [[mdpi.com](https://mdpi.com)]
- 7. Novel irreversible peptidic inhibitors of transglutaminase 2 - PMC [[pmc.ncbi.nlm.nih.gov](https://pubmed.ncbi.nlm.nih.gov)]
- 8. Synthesis, Characterization, and Biologic Activity of New Acyl Hydrazides and 1,3,4-Oxadiazole Derivatives - PMC [[pmc.ncbi.nlm.nih.gov](https://pubmed.ncbi.nlm.nih.gov)]
- 9. [mdpi.com](https://mdpi.com) [[mdpi.com](https://mdpi.com)]
- 10. Mini-Review of the Importance of Hydrazides and Their Derivatives—Synthesis and Biological Activity [[mdpi.com](https://mdpi.com)]
- 11. Novel acyl hydrazide derivatives of polyhydroquinoline as potent anti-diabetic and anti-glycating agents: Synthesis, in vitro  $\alpha$ -amylase,  $\alpha$ -glucosidase inhibition and anti-glycating activity with molecular docking insights - PubMed [[pubmed.ncbi.nlm.nih.gov](https://pubmed.ncbi.nlm.nih.gov)]
- 12. Cell-Impermeable Inhibitors Confirm That Intracellular Human Transglutaminase 2 Is Responsible for the Transglutaminase-Associated Cancer Phenotype - PMC [[pmc.ncbi.nlm.nih.gov](https://pubmed.ncbi.nlm.nih.gov)]
- 13. [mdpi.com](https://mdpi.com) [[mdpi.com](https://mdpi.com)]
- To cite this document: BenchChem. [Technical Support Center: Enhancing Cell Permeability of Transglutaminase 2 (TG2) Inhibitors]. BenchChem, [2026]. [Online PDF]. Available at: [<https://www.benchchem.com/product/b2568743/docs#technical-support-center-enhancing-cell-permeability-of-transglutaminase-2-tg2-inhibitors>]

---

### Disclaimer & Data Validity:

The information provided in this document is for Research Use Only (RUO) and is strictly not intended for diagnostic or therapeutic procedures. While BenchChem strives to provide

accurate protocols, we make no warranties, express or implied, regarding the fitness of this product for every specific experimental setup.

**Technical Support:** The protocols provided are for reference purposes. Unsure if this reagent suits your experiment?

**Need Industrial/Bulk Grade?** [Request Custom Synthesis Quote](#)

## BenchChem

Our mission is to be the trusted global source of essential and advanced chemicals, empowering scientists and researchers to drive progress in science and industry.

### Contact

Address: 3281 E Guasti Rd

Ontario, CA 91761, United States

Phone: (601) 213-4426

Email: [info@benchchem.com](mailto:info@benchchem.com)

[Contact our Ph.D. Support Team for a compatibility check](#)