

Technical Support Center: Optimizing the Synthesis of 7-Nitroisoquinolin-4-amine

Author: BenchChem Technical Support Team. **Date:** April 2026

Compound of Interest

Compound Name: 7-Nitroisoquinolin-4-amine

CAS No.: 1936476-62-8

Cat. No.: B2565815

[Get Quote](#)

Welcome to the Technical Support Center for the synthesis of **7-Nitroisoquinolin-4-amine**. As a Senior Application Scientist, I have designed this troubleshooting guide to assist researchers, medicinal chemists, and drug development professionals in optimizing this specific synthetic pathway.

The synthesis of this privileged scaffold relies on a critical two-step sequence starting from 7-nitroisoquinoline: a regioselective electrophilic C4-bromination, followed by a palladium-catalyzed Buchwald-Hartwig amination. This guide deconstructs the mechanistic causality behind common experimental failures and provides self-validating protocols to ensure high-yield, reproducible results.

Core Synthetic Workflow

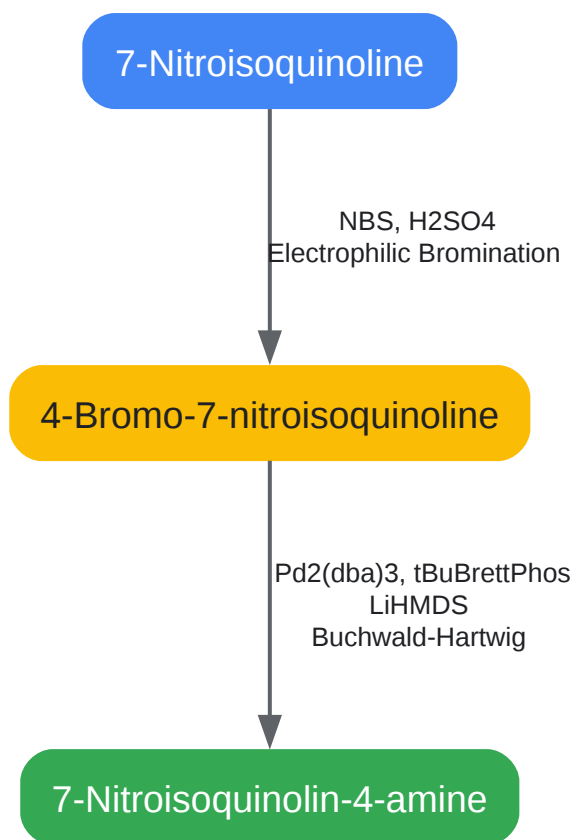

[Click to download full resolution via product page](#)

Figure 1: Two-step synthetic workflow for **7-Nitroisoquinolin-4-amine**.

Part 1: Optimization Data for C-N Coupling

Before diving into the troubleshooting FAQs, review the catalyst and condition optimization data for the critical Buchwald-Hartwig amination step. The extreme electronic deactivation caused by the nitro group requires highly specific ligand selection.

Entry	Catalyst / Ligand	Nitrogen Source	Base / Solvent	Temp (°C)	Yield (%)	Observation
1	Pd(OAc) ₂ / PPh ₃	Aqueous NH ₃	K ₂ CO ₃ / Dioxane	100	< 5%	Catalyst poisoning; no conversion.
2	Pd ₂ (dba) ₃ / BINAP	Benzophenone imine	NaOtBu / Toluene	90	45%	Significant nitro group reduction.
3	Pd ₂ (dba) ₃ / BrettPhos	LiHMDS	LiHMDS / THF	65	72%	Moderate conversion; some dehalogenation.
4	Pd ₂ (dba) ₃ / tBuBrettPhos	LiHMDS	LiHMDS / THF	65	89%	Clean conversion; primary amine isolated.

Part 2: Troubleshooting Guides & FAQs

Q1: During the bromination of 7-nitroisoquinoline, I am recovering mostly unreacted starting material even with excess Br₂. Why is the reaction stalling? A1: The causality here lies in the electronic nature of your substrate. The 7-nitro group is a powerful electron-withdrawing group (EWG) that severely deactivates the isoquinoline core toward electrophilic aromatic substitution[1]. Standard bromination conditions (e.g., Br₂ in acetic acid) lack the necessary electrophilicity. Mitigation: Switch your brominating agent to N-bromosuccinimide (NBS) in concentrated sulfuric acid (H₂SO₄)[2]. In this superacidic medium, the isoquinoline nitrogen is protonated, and NBS is activated to generate a highly reactive bromonium (Br⁺) equivalent. This overcomes the deactivation barrier, selectively attacking the C4 position—the most nucleophilic site on the pyridine ring of the isoquinolinium ion[3].

Q2: I successfully synthesized 4-bromo-7-nitroisoquinoline, but my Buchwald-Hartwig amination yields mostly 7-nitroisoquinoline (dehalogenation). How do I prevent this? A2: Protodehalogenation is a classic competing side reaction in cross-coupling. It occurs when the palladium oxidative addition complex undergoes hydrogen abstraction or β -hydride elimination before the amine can coordinate and reductively eliminate. The strongly electron-withdrawing 7-nitro group depletes electron density from the Pd(II) center, slowing down the reductive elimination step. Mitigation: You must accelerate the reductive elimination. Transition to a highly sterically hindered, electron-rich biaryl phosphine ligand like tBuBrettPhos[4][5]. The extreme steric bulk of tBuBrettPhos forces the Pd center into a geometry that dramatically accelerates C-N reductive elimination, outcompeting the off-cycle dehalogenation pathway[5].

Q3: Can I use aqueous ammonia directly for the amination step to save time? A3: It is highly discouraged. While direct amination with ammonia gas or aqueous ammonia is documented for simpler aryl halides[4], applying it to a deactivated, nitro-bearing heteroaryl bromide often fails. Ammonia can form stable, unreactive Werner-type complexes with Palladium [Pd(NH₃)_x], effectively poisoning the catalyst[6]. Furthermore, the presence of water at elevated temperatures can hydrolyze the starting material or degrade the catalyst. Mitigation: Use an ammonia surrogate such as lithium hexamethyldisilazide (LiHMDS)[4]. LiHMDS acts as both the base and the nitrogen nucleophile. It couples efficiently with the Pd complex and, upon mild acidic workup, the silyl groups are cleaved to reveal the primary amine in high yield.

Q4: I used NaOtBu as the base in my amination, but I observed a complex mixture with missing nitro-group signals in the NMR. What happened? A4: Sodium tert-butoxide (NaOtBu) is a strong base commonly used in Buchwald-Hartwig aminations, but it is incompatible with nitroaromatics. At elevated temperatures, NaOtBu can act as a single-electron donor, leading to the reduction of the nitro group to azoxy, azo, or amino derivatives, creating a complex impurity profile. Mitigation: Use a milder, non-nucleophilic base. When using LiHMDS as the nitrogen source, no additional base is required (it is sufficiently basic). If using benzophenone imine as the surrogate, use Cesium Carbonate (Cs₂CO₃) or Potassium Phosphate (K₃PO₄) to ensure nitro-group tolerance[7].

Part 3: Self-Validating Experimental Protocols

Protocol 1: Regioselective Synthesis of 4-Bromo-7-nitroisoquinoline

Mechanism: Electrophilic aromatic substitution via an acid-activated bromonium ion.

- Preparation: In an oven-dried round-bottom flask, dissolve 7-nitroisoquinoline (1.0 eq) in concentrated H₂SO₄ (0.5 M) at 0 °C under an argon atmosphere.
- Activation: Slowly add N-bromosuccinimide (NBS, 1.2 eq) in small portions over 30 minutes to control the exotherm and prevent over-bromination.
- Reaction: Allow the mixture to warm to room temperature and stir for 12 hours.
- In-Process Control (IPC): Quench a 50 µL aliquot into sat. NaHCO₃ and extract with EtOAc. Analyze by LC-MS. The reaction is complete when the starting material (m/z 175 [M+H]⁺) is consumed, and the product (m/z 253/255 [M+H]⁺, 1:1 isotopic ratio) is the major peak.
- Workup: Carefully pour the acidic mixture over crushed ice. Neutralize slowly with solid Na₂CO₃ until pH 8. Extract with EtOAc (3x). Wash the combined organics with brine, dry over anhydrous Na₂SO₄, and concentrate in vacuo.
- Validation: Purify via flash chromatography (Hexanes/EtOAc). ¹H NMR should show the disappearance of the C4 proton (typically around 8.5 ppm) and a singlet for the C3 proton, confirming regioselectivity.

Protocol 2: Buchwald-Hartwig Amination to 7-Nitroisoquinolin-4-amine

Mechanism: Pd-catalyzed C-N cross-coupling using an ammonia surrogate.

- Preparation: In a rigorous nitrogen-filled glovebox, charge a Schlenk tube with 4-bromo-7-nitroisoquinoline (1.0 eq), Pd₂(dba)₃ (0.05 eq), and tBuBrettPhos (0.12 eq).
- Solvent & Reagent Addition: Add anhydrous, degassed THF (0.2 M). Stir for 5 minutes to pre-form the active catalyst complex (solution turns dark red/brown). Add a 1.0 M solution of LiHMDS in THF (2.5 eq) dropwise.
- Reaction: Seal the tube, remove it from the glovebox, and heat at 65 °C for 4 hours.
- In-Process Control (IPC): Analyze an aliquot by TLC (DCM:MeOH 9:1). The bromo-intermediate should be fully consumed.

- Deprotection (Hydrolysis): Cool the reaction to 0 °C. Carefully add 1.0 M HCl (aqueous) until the pH reaches 2. Stir for 30 minutes at room temperature to cleave the silyl groups from the coupled intermediate.
- Workup: Basify the mixture to pH 10 using 1.0 M NaOH. Extract the aqueous layer with a mixture of CHCl₃/Isopropanol (3:1) to ensure the highly polar amine is fully extracted. Dry over Na₂SO₄ and concentrate.
- Validation: ¹H NMR (DMSO-d₆) will show a broad singlet integrating for 2 protons around 6.5-7.0 ppm (the -NH₂ group), and the preservation of the nitro group signals.

References

- Benchchem. 7-Bromo-5-nitroisoquinoline (Mechanistic principles of nitroisoquinoline bromination).[1](#)
- PMC - NIH. Evolution of a Fourth Generation Catalyst for the Amination and Thioetherification of Aryl Halides.[4](#)
- ResearchGate. Bromination of Isoquinoline, Quinoline, Quinazoline and Quinoxaline in Strong Acid.[2](#)
- ResearchGate. The Buchwald–Hartwig Amination After 25 Years.[5](#)
- Thieme Connect. Product Class 5: Isoquinolines.[3](#)
- ChemRxiv. A Chemo- and Regioselective Tandem [3+2]Heteroannulation Strategy for Carbazole Synthesis.[7](#)
- Thieme Connect. Aryl- and Hetaryl amines with Hetaryl Electrophiles.[6](#)

Need Custom Synthesis?

BenchChem offers custom synthesis for rare earth carbides and specific isotopic labeling.

Email: info@benchchem.com or [Request Quote Online](#).

Sources

- [1. 7-Bromo-5-nitroisoquinoline | Benchchem \[benchchem.com\]](#)
- [2. researchgate.net \[researchgate.net\]](#)
- [3. Thieme E-Books & E-Journals \[thieme-connect.de\]](#)
- [4. pmc.ncbi.nlm.nih.gov \[pmc.ncbi.nlm.nih.gov\]](#)
- [5. researchgate.net \[researchgate.net\]](#)
- [6. Thieme E-Books & E-Journals \[thieme-connect.de\]](#)
- [7. chemrxiv.org \[chemrxiv.org\]](#)
- To cite this document: BenchChem. [Technical Support Center: Optimizing the Synthesis of 7-Nitroisoquinolin-4-amine]. BenchChem, [2026]. [Online PDF]. Available at: [\[https://www.benchchem.com/product/b2565815/docs#technical-support-center-optimizing-the-synthesis-of-7-nitroisoquinolin-4-amine\]](https://www.benchchem.com/product/b2565815/docs#technical-support-center-optimizing-the-synthesis-of-7-nitroisoquinolin-4-amine)

Disclaimer & Data Validity:

The information provided in this document is for Research Use Only (RUO) and is strictly not intended for diagnostic or therapeutic procedures. While BenchChem strives to provide accurate protocols, we make no warranties, express or implied, regarding the fitness of this product for every specific experimental setup.

Technical Support: The protocols provided are for reference purposes. Unsure if this reagent suits your experiment?

Need Industrial/Bulk Grade? [Request Custom Synthesis Quote](#)

BenchChem

Our mission is to be the trusted global source of essential and advanced chemicals, empowering scientists and researchers to drive progress in science and industry.

Contact

Address: 3281 E Guasti Rd
Ontario, CA 91761, United States
Phone: (601) 213-4426
Email: info@benchchem.com

Contact our Ph.D. Support Team for a compatibility check