

# Technical Support Center: Solving Solubility Issues of 2-(2-Aminoethoxy)ethylamine Complexes

**Author:** BenchChem Technical Support Team. **Date:** May 2026

## Compound of Interest

Compound Name:	[2-(2-Aminoethoxy)ethyl] (ethyl)amine
CAS No.:	1011486-26-2
Cat. No.:	B2564100

[Get Quote](#)

Last Updated: February 21, 2026

## Introduction

Welcome to the technical support guide for researchers, scientists, and drug development professionals working with 2-(2-Aminoethoxy)ethylamine and its metal complexes. 2-(2-Aminoethoxy)ethylamine, also known as DAEA or by its trade name Jeffamine® EDR-148, is a versatile and highly reactive polyetheramine.[1][2][3] Its structure, featuring two primary amine groups and an ether linkage, makes it an excellent chelating agent for a wide variety of metal ions. However, the very properties that make DAEA a strong ligand can also lead to significant solubility challenges. The formation of stable, often polymeric, coordination complexes can result in products that are poorly soluble in common organic solvents or aqueous systems.[4]

This guide is designed to serve as a first-line resource for troubleshooting these common solubility problems. It is structured in a question-and-answer format to directly address the specific issues you may encounter during your experiments. Our goal is to provide not only

procedural steps but also the underlying scientific reasoning to empower you to make informed decisions in your work.

## Troubleshooting Guides & FAQs

### Question 1: My DAEA complex precipitates out of solution immediately upon synthesis. What are the first things I should check?

This is a very common issue, often stemming from high lattice energy in the resulting complex or the formation of an insoluble coordination polymer. Here are the initial steps to troubleshoot:

Answer:

Immediate precipitation suggests that the complex is highly stable in its solid form and not well-solvated by the reaction medium. The primary factors to investigate are solvent choice and reactant concentrations.

Initial Troubleshooting Steps:

- **Re-evaluate Your Solvent System:** The principle of "like dissolves like" is paramount. If your DAEA ligand is polar and your metal salt is polar, but the resulting complex has a different overall polarity, it may precipitate.
  - **Increase Solvent Polarity:** Try more polar aprotic solvents like DMSO, DMF, or NMP. These solvents are often effective at solvating charged or highly polar complexes.<sup>[5]</sup>
  - **Solvent Mixtures:** A mixture of solvents can sometimes provide the ideal balance of polarity and coordinating ability to keep a complex in solution. For example, a mixture of methanol and dichloromethane can be effective.
  - **Consider Coordinating Solvents:** Solvents that can also act as weak ligands (like water, methanol, or acetonitrile) may help by coordinating to the metal center and preventing the immediate formation of an extended, insoluble lattice.<sup>[6]</sup>
- **Lower Reactant Concentrations:** High concentrations favor precipitation and the formation of large, insoluble polymeric structures.

- Protocol: Reduce the concentration of both the metal salt and the DAEA ligand by a factor of 5 or 10. Perform the reaction under these more dilute conditions and observe if the complex remains in solution longer or dissolves completely.
- Control the Rate of Addition: Adding one reactant too quickly to the other can create localized areas of high concentration, promoting rapid precipitation.
  - Protocol: Use a syringe pump to add the ligand solution to the metal salt solution dropwise over a period of 30-60 minutes with vigorous stirring. This maintains a low concentration of the limiting reagent and allows for more controlled complex formation.

## Question 2: How does pH affect the solubility of my DAEA complex, and how can I optimize it?

Answer:

The pH of your solution is a critical variable because the DAEA ligand has two primary amine groups that can be protonated. The protonation state affects the ligand's charge and its ability to coordinate with the metal ion, thereby influencing the overall charge and solubility of the complex.<sup>[7]</sup>

The Underlying Mechanism:

- Low pH (Acidic): In acidic conditions, the amine groups of DAEA will be protonated ( $-\text{NH}_3^+$ ). This can prevent coordination with the metal center, as the lone pair of electrons on the nitrogen is no longer available.<sup>[7]</sup>
- High pH (Basic): In basic conditions, the amine groups are deprotonated ( $-\text{NH}_2$ ) and are excellent donors for the metal ion. However, excessively high pH can lead to the precipitation of metal hydroxides (e.g.,  $\text{Cu}(\text{OH})_2$ ), which competes with your desired complex formation.<sup>[7]</sup>

Protocol for pH Optimization:

- Determine the pKa of DAEA: The pKa values for the conjugate acids of aliphatic amines are typically in the range of 9-11.<sup>[8]</sup> It is crucial to operate at a pH where the amine groups are

sufficiently deprotonated to coordinate effectively without causing metal hydroxide precipitation.

- **Buffered Synthesis:** Prepare a series of buffered solutions (e.g., acetate, phosphate, borate) spanning a pH range from 4 to 10.
- **Small-Scale Screening:** Run the complexation reaction in parallel in each of these buffered solutions on a small scale.
- **Observation:** Note the pH at which the complex remains soluble. You can quantify this by measuring the concentration of the dissolved complex using techniques like UV-Vis spectroscopy if the complex has a chromophore.

Parameter	Effect on DAEA Ligand	Potential Impact on Complex Solubility	Consideration
Low pH (< 7)	Amine groups are protonated (-NH <sub>3</sub> <sup>+</sup> )	May prevent complex formation entirely. If a complex does form, its high positive charge could increase solubility in polar solvents.	Risk of ligand inactivity.
Neutral pH (~7)	A mix of protonated and deprotonated states.	Solubility is highly dependent on the specific metal and counter-ion.	A good starting point for many systems.
High pH (> 8)	Amine groups are deprotonated (-NH <sub>2</sub> )	Promotes strong coordination. However, can lead to insoluble metal hydroxide precipitation.	Monitor for signs of metal hydroxide formation (e.g., gelatinous precipitates).

## Question 3: My complex is still insoluble. Could the counter-ion be the problem?

Answer:

Absolutely. The counter-ion, which is the ion that balances the charge of the coordination complex, plays a significant role in the solubility of the final product.<sup>[9][10]</sup> This is because the counter-ion is a key component of the crystal lattice.

The Role of the Counter-Ion:

The insolubility of a salt is often due to a high lattice energy—the energy required to break apart the ionic crystal. By changing the counter-ion, you can significantly alter this lattice energy.

- Small, Hard Anions (e.g.,  $\text{Cl}^-$ ,  $\text{SO}_4^{2-}$ ): These ions often lead to strong ionic interactions and high lattice energies, resulting in lower solubility.
- Large, Diffuse Anions (e.g.,  $\text{NO}_3^-$ ,  $\text{BF}_4^-$ ,  $\text{PF}_6^-$ , Triflate ( $\text{OTf}^-$ )): These ions have their charge spread over a larger volume. This leads to weaker ionic interactions (lower lattice energy) and often dramatically increases solubility in organic solvents.<sup>[4]</sup>

Experimental Protocol for Counter-Ion Exchange:

- Select a Soluble Salt: Start your synthesis with a metal salt that has a more "solubility-enhancing" counter-ion. For example, instead of using copper(II) chloride, try copper(II) nitrate or copper(II) triflate.
- Metathesis Reaction (Post-Synthesis): If you have already synthesized an insoluble complex with a "poor" counter-ion (e.g.,  $[\text{M}(\text{DAEA})\text{Cl}_2]$ ), you can attempt a salt metathesis reaction.
  - Suspend your insoluble chloride salt in a solvent like methanol.
  - Add a soluble silver salt with a "good" counter-ion, such as silver nitrate ( $\text{AgNO}_3$ ) or silver triflate ( $\text{AgOTf}$ ).

- The silver will precipitate with the chloride (AgCl), leaving your complex in solution with the new, more favorable counter-ion.
- Filter off the AgCl precipitate to obtain a solution of your more soluble complex.

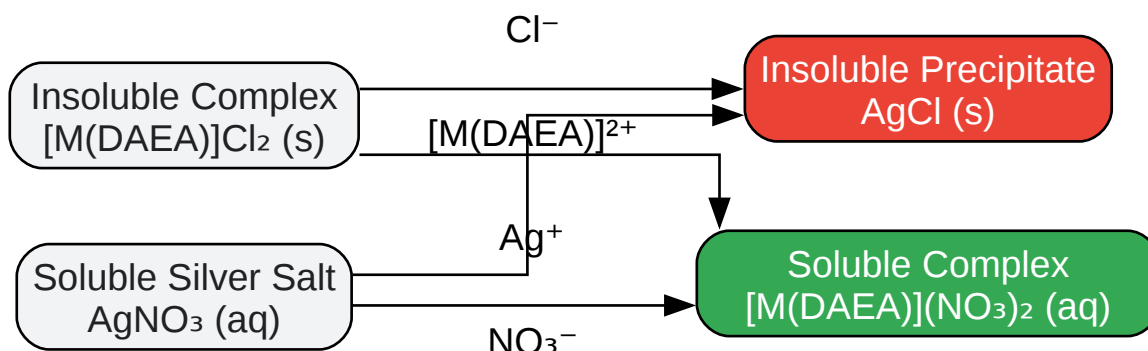

[Click to download full resolution via product page](#)

Caption: Workflow for counter-ion metathesis to improve solubility.

## Question 4: I suspect my complex is an insoluble coordination polymer. How can I confirm this and modify my synthesis to prevent it?

Answer:

DAEA is a flexible ligand that can bridge between two metal centers, leading to the formation of one-, two-, or three-dimensional coordination polymers. These extended structures are often highly insoluble.<sup>[4]</sup>

Confirming Polymeric Nature:

- Insolubility: Extreme insolubility in all common solvents is a strong indicator.<sup>[4]</sup>
- Characterization: Techniques like Powder X-ray Diffraction (PXRD) will show sharp peaks indicative of a crystalline, ordered material, which is common for coordination polymers. Infrared (IR) spectroscopy can confirm the coordination of the DAEA ligand to the metal.

Strategies to Prevent Polymerization:

- Change the Metal-to-Ligand Stoichiometry:
  - Mechanism: Using an excess of the ligand can favor the formation of discrete, mononuclear complexes where a single metal ion is fully saturated by multiple DAEA ligands, rather than DAEA bridging between metals.
  - Protocol: Set up reactions with varying metal-to-ligand ratios, such as 1:1, 1:2, and 1:3. Analyze the solubility of the resulting products.
- Introduce a Capping Ligand:
  - Mechanism: A capping ligand is a monodentate ligand (a ligand that can only bind to the metal at one site) that will occupy some of the metal's coordination sites, physically blocking the formation of an extended polymer network.
  - Protocol: In addition to your metal salt and DAEA, add a simple monodentate ligand to the reaction mixture. Good examples include pyridine, triphenylphosphine, or even a simple halide like chloride from an excess of a salt like LiCl.

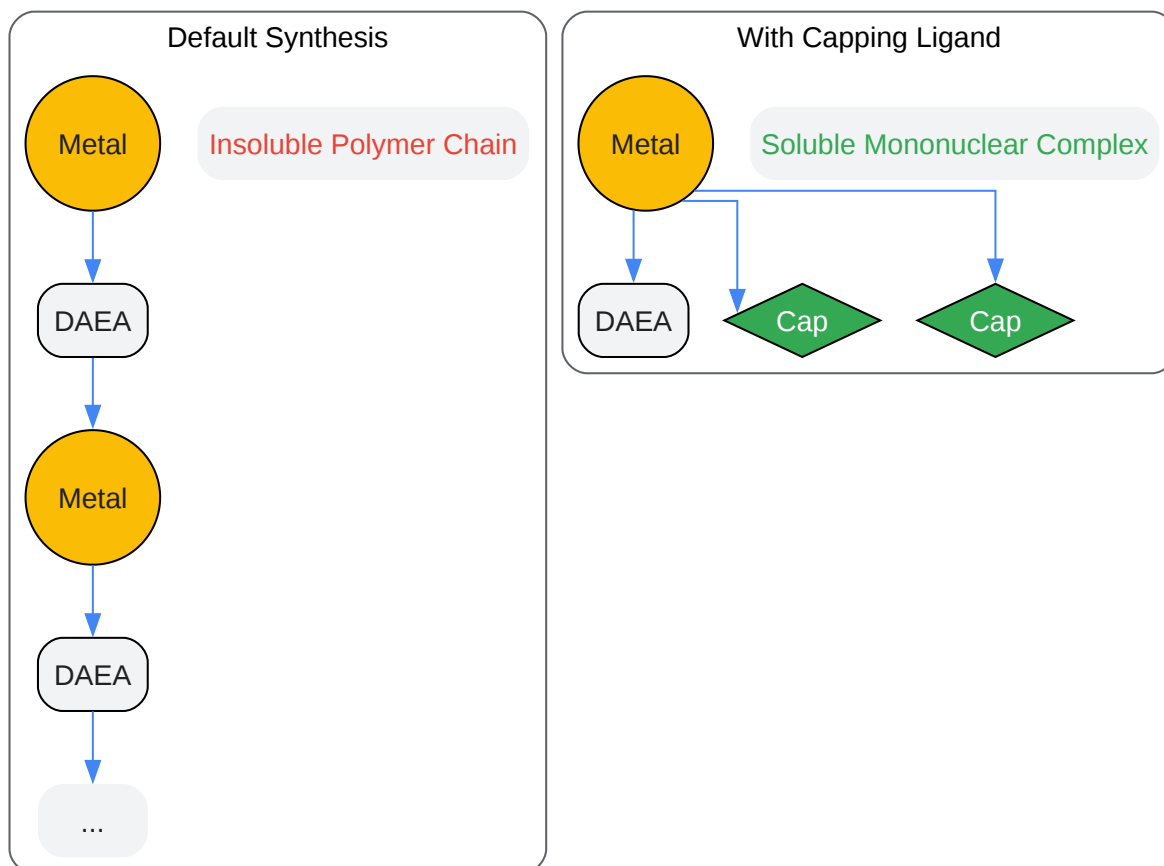

[Click to download full resolution via product page](#)

Caption: Capping ligands block coordination sites to prevent polymerization.

## References

- Factors Affecting Stability of Complexes. (n.d.). Solubility of Things. Retrieved February 21, 2026, from [\[Link\]](#)
- Which ion is the counterion in the coordination compound. (n.d.). Vaia. Retrieved February 21, 2026, from [\[Link\]](#)

- Jeffamine® Edr-148 TDS. (n.d.). Scribd. Retrieved February 21, 2026, from [[Link](#)]
- Coordination Chemistry. (2024-2025). Dr. Taghreed Mohy Aldin Musa. Retrieved February 21, 2026, from [[Link](#)]
- JEFFAMINE EDR-148 - Polyether Amines. (n.d.). Huntsman. Retrieved February 21, 2026, from [[Link](#)]
- Metal-Organic Frameworks: Synthetic Methods and Potential Applications. (2018). PMC. Retrieved February 21, 2026, from [[Link](#)]
- How to find a better solution for the solubility of metal complexes? (2021, July 9). ResearchGate. Retrieved February 21, 2026, from [[Link](#)]
- Factors that Affect Solubility. (2026, January 27). Chemistry LibreTexts. Retrieved February 21, 2026, from [[Link](#)]
- pKa Data Compiled by R. Williams. (2022, April 7). Organic Chemistry Data. Retrieved February 21, 2026, from [[Link](#)]

### *Need Custom Synthesis?*

*BenchChem offers custom synthesis for rare earth carbides and specific isotopic labeling.*

*Email: [info@benchchem.com](mailto:info@benchchem.com) or [Request Quote Online](#).*

## Sources

- 1. [specialchem.com](https://specialchem.com) [[specialchem.com](https://specialchem.com)]
- 2. [explore.azelis.com](https://explore.azelis.com) [[explore.azelis.com](https://explore.azelis.com)]
- 3. Huntsman - JEFFAMINE EDR-148 - Polyether Amines - High Purity - EP [[products.huntsman.com](https://products.huntsman.com)]
- 4. [researchgate.net](https://researchgate.net) [[researchgate.net](https://researchgate.net)]
- 5. Metal-Organic Frameworks: Synthetic Methods and Potential Applications - PMC [[pmc.ncbi.nlm.nih.gov](https://pmc.ncbi.nlm.nih.gov)]
- 6. [ossila.com](https://ossila.com) [[ossila.com](https://ossila.com)]

- [7. solubilityofthings.com](https://www.solubilityofthings.com) [[solubilityofthings.com](https://www.solubilityofthings.com)]
- [8. chem.indiana.edu](https://chem.indiana.edu) [[chem.indiana.edu](https://chem.indiana.edu)]
- [9. vaia.com](https://www.vaia.com) [[vaia.com](https://www.vaia.com)]
- [10. uomustansiriyah.edu.iq](https://uomustansiriyah.edu.iq) [[uomustansiriyah.edu.iq](https://uomustansiriyah.edu.iq)]
- To cite this document: BenchChem. [Technical Support Center: Solving Solubility Issues of 2-(2-Aminoethoxy)ethylamine Complexes]. BenchChem, [2026]. [Online PDF]. Available at: [<https://www.benchchem.com/product/b2564100/docs#technical-support-center-solving-solubility-issues-of-2-2-aminoethoxy-ethylamine-complexes>]

---

### Disclaimer & Data Validity:

The information provided in this document is for Research Use Only (RUO) and is strictly not intended for diagnostic or therapeutic procedures. While BenchChem strives to provide accurate protocols, we make no warranties, express or implied, regarding the fitness of this product for every specific experimental setup.

**Technical Support:** The protocols provided are for reference purposes. Unsure if this reagent suits your experiment?

**Need Industrial/Bulk Grade?** [Request Custom Synthesis Quote](#)

## BenchChem

Our mission is to be the trusted global source of essential and advanced chemicals, empowering scientists and researchers to drive progress in science and industry.

### Contact

Address: 3281 E Guasti Rd

Ontario, CA 91761, United States

Phone: (601) 213-4426

Email: [info@benchchem.com](mailto:info@benchchem.com)

[Contact our Ph.D. Support Team for a compatibility check](#)

