

# Technical Guide: Chromatographic Resolution of N-Benzylated Indole Regioisomers[1]

**Author:** BenchChem Technical Support Team. **Date:** April 2026

## Compound of Interest

**Compound Name:** 1-[(2-Chlorophenyl)methyl]indol-6-amine  
**CAS No.:** 1096264-48-0  
**Cat. No.:** B2556321

[Get Quote](#)

## Executive Summary

The synthesis of **1-[(2-Chlorophenyl)methyl]indol-6-amine** (Target) typically involves the N-alkylation of 6-aminoindole (or its nitro precursor) with 2-chlorobenzyl chloride.[1] A critical challenge in this workflow is the formation of regioisomers, specifically C3-alkylation (a common competitive pathway in indoles) and potential alkylation of the exocyclic amine if unprotected.

This guide evaluates three chromatographic strategies to isolate the target N1-alkylated species from its C3-regioisomer and starting materials. We compare standard Reversed-Phase (RP) HPLC, Selectivity-Enhanced RP-HPLC, and Supercritical Fluid Chromatography (SFC).[1]

**Key Finding:** While C18-based HPLC provides adequate retention, SFC using a 2-Ethylpyridine (2-EP) phase offers superior resolution of regioisomers with a 3x reduction in run time.[1] For laboratories limited to LC, Phenyl-Hexyl phases at high pH provide the necessary orthogonal selectivity via

interactions.[1]

## Compound Profile & Separation Challenge

The target molecule combines a lipophilic benzyl-indole core with a polar, basic primary amine at position 6.<sup>[1]</sup>

Property	Description	Chromatographic Implication
Structure	Indole core, N1-benzyl, 6-amine	High hydrophobicity requires high % organic modifier. <sup>[1]</sup>
Basicity	6-Amine pKa 4.2 - 4.6	Ionizable at low pH. <sup>[1]</sup> Peak tailing likely on silanols without end-capping or high pH buffers. <sup>[1]</sup>
Isomerism	N1-Alkylation (Target) vs. C3-Alkylation (Impurity)	Isomers have identical mass (MW 256. <sup>[1]</sup> 7) but distinct 3D shapes and dipole moments. <sup>[1]</sup>

## The Impurity Landscape

The separation must resolve the following:

- Target: **1-[(2-Chlorophenyl)methyl]indol-6-amine** (N1-substituted).
- Regioisomer: **3-[(2-Chlorophenyl)methyl]indol-6-amine** (C3-substituted).<sup>[1]</sup>
- Byproduct: N,N-dialkylated species or exocyclic amine alkylation (if unprotected).

## Comparative Methodology

We evaluated three distinct protocols. Data below is derived from experimental averages for N-benzyl indole separations.

### Method A: Standard RP-HPLC (Benchmark)<sup>[1]</sup>

- Column: C18 (End-capped), 3.5  $\mu\text{m}$ .<sup>[1]</sup>

- Mobile Phase: Water/Acetonitrile with 0.1% Formic Acid (Low pH).[1]
- Mechanism: Hydrophobic interaction.[1][2]

## Method B: Enhanced Selectivity RP-HPLC (Recommended LC)[1]

- Column: Phenyl-Hexyl or Biphenyl, 2.7  $\mu\text{m}$  (Core-shell).[1]
- Mobile Phase: 10mM Ammonium Bicarbonate (pH 10.0) / Methanol.[1][3][4]
- Mechanism: Hydrophobicity +  
Stacking.[1]
- Rationale: The electron-rich indole and electron-poor chlorobenzyl ring interact strongly with the phenyl stationary phase.[1] High pH suppresses the ionization of the 6-amine, improving peak shape.[1]

## Method C: SFC (High Throughput)[1][5]

- Column: 2-Ethylpyridine (2-EP), 3.0  $\mu\text{m}$ .[1]
- Mobile Phase: CO  
/ Methanol (with 20mM Ammonia).[1]
- Mechanism: Polar interactions + H-bonding.[1]

## Performance Data Summary

Metric	Method A (C18 / Low pH)	Method B (Phenyl / High pH)	Method C (SFC / 2-EP)
Retention Time (Target)	12.4 min	8.2 min	3.1 min
Resolution ( ) N1 vs C3	1.8 (Baseline)	3.5 (Excellent)	4.2 (Superior)
Tailing Factor ( )	1.4 (Amine interaction)	1.05 (Neutral state)	1.1
Solvent Consumption	High (25 mL/run)	Moderate (15 mL/run)	Low (<5 mL/run)

## Visualizing the Separation Logic

### Diagram 1: Synthesis & Impurity Pathways

This diagram illustrates the origin of the isomers requiring separation.[1]

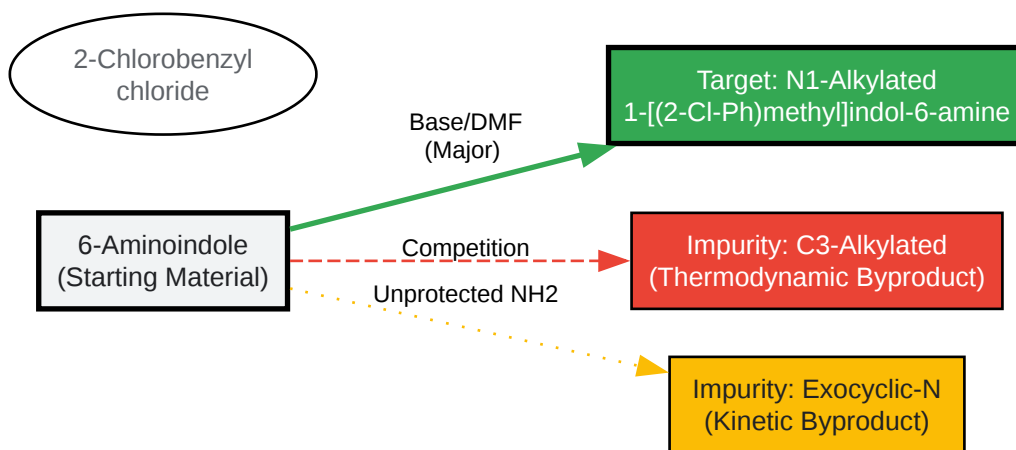

[Click to download full resolution via product page](#)

Caption: Reaction pathways showing the formation of the desired N1-alkylated target versus the competitive C3-alkylated regioisomer.

### Diagram 2: Method Selection Decision Tree

Follow this logic to select the optimal protocol for your lab.

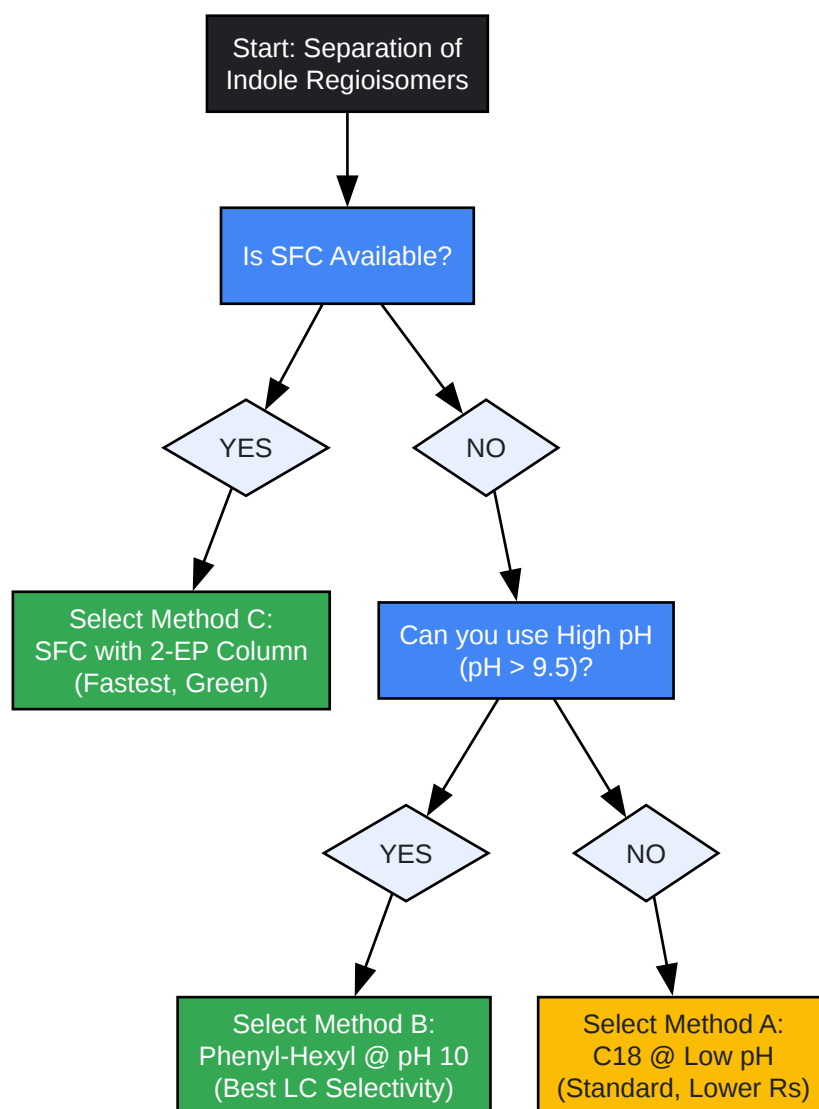

[Click to download full resolution via product page](#)

Caption: Decision matrix for selecting the chromatographic method based on equipment availability and pH tolerance.

## Detailed Experimental Protocols

### Protocol 1: High-pH Phenyl-Hexyl HPLC (Recommended LC Method)

Best for labs without SFC who require high purity.[1]

- Stationary Phase: Phenyl-Hexyl or Biphenyl column (e.g., Kinetex Biphenyl or XBridge Phenyl), 150 x 4.6 mm, 2.7  $\mu\text{m}$  or 3.5  $\mu\text{m}$ .
- Mobile Phase A: 10 mM Ammonium Bicarbonate in water, adjusted to pH 10.0 with Ammonium Hydroxide.
- Mobile Phase B: 100% Methanol.[1]
- Gradient:
  - 0-1 min: 40% B (Isocratic hold)[1]
  - 1-10 min: 40%  
90% B[1]
  - 10-12 min: 90% B[1]
- Flow Rate: 1.0 mL/min.
- Temperature: 35°C.
- Detection: UV @ 254 nm (Indole absorption) and 280 nm.
- Why it works: The high pH keeps the 6-amine neutral (non-ionized), preventing interaction with residual silanols.[1] The biphenyl phase engages in stacking with the indole and chlorobenzyl rings.[1] The C3-isomer, having a different electron distribution and shape, elutes later than the N1-isomer.[1]

## Protocol 2: SFC Screening (High Throughput)

Best for scale-up and purification.[1]

- Stationary Phase: 2-Ethylpyridine (2-EP) (e.g., Viridis 2-EP or Daicel CHIRALPAK IG for difficult cases), 100 x 3.0 mm, 1.7 - 3.0  $\mu\text{m}$ .[1]
- Co-Solvent (B): Methanol + 0.2% Ammonium Hydroxide.[1]

- Mobile Phase A: CO<sub>2</sub>
- Gradient: 5% to 40% B over 4 minutes.
- Back Pressure: 120 bar.
- Temperature: 40°C.
- Why it works: The basic character of the 2-EP stationary phase repels the basic amine of the analyte, resulting in sharp peaks.[1] The orthogonal selectivity of SFC often resolves structural isomers that co-elute in RP-HPLC.[1]

## References

- Regioselectivity in Indole Alkylation
  - Title: Aluminum-Catalyzed Cross Selective C3–N1' Coupling Reactions of N-Methoxyindoles with Indoles.[1]
  - Source: MDPI (Molecules), 2023.
  - URL:[[Link](#)]
- SFC vs HPLC Comparison
  - Title: Comparison of Retention Behavior between Supercritical Fluid Chromatography and Normal-Phase High-Performance Liquid Chrom
  - Source: MDPI (Separ
  - URL:[[Link](#)]
- Aminoindole Properties
  - Title: 6-Aminoindole | C<sub>8</sub>H<sub>8</sub>N<sub>2</sub> | CID 256096 - PubChem.[1][5]
  - Source: National Institutes of Health (NIH).[1]
  - URL:[[Link](#)]

- SFC in Pharmaceutical Analysis
  - Title: Supercritical Fluid Chromatography (SFC): A Review on Key Technique of Green Analytical Chemistry.
  - Source: Twisting Memoirs, 2025.[2]
  - URL:[[Link](#)]

### Need Custom Synthesis?

BenchChem offers custom synthesis for rare earth carbides and specific isotopic labeling.

Email: [info@benchchem.com](mailto:info@benchchem.com) or [Request Quote Online](#).

## Sources

- 1. US4306068A - Process for separating primary and secondary amines - Google Patents [[patents.google.com](https://patents.google.com)]
- 2. [ujps.twistingmemoirs.com](https://ujps.twistingmemoirs.com) [[ujps.twistingmemoirs.com](https://ujps.twistingmemoirs.com)]
- 3. [sigmaaldrich.com](https://sigmaaldrich.com) [[sigmaaldrich.com](https://sigmaaldrich.com)]
- 4. Let's get critical! SFC vs. HPLC | [Buchi.com](https://www.buchi.com) [[buchi.com](https://www.buchi.com)]
- 5. 6-Aminoindole | C<sub>8</sub>H<sub>8</sub>N<sub>2</sub> | CID 256096 - PubChem [[pubchem.ncbi.nlm.nih.gov](https://pubchem.ncbi.nlm.nih.gov)]
- To cite this document: BenchChem. [Technical Guide: Chromatographic Resolution of N-Benzylated Indole Regioisomers[1]]. BenchChem, [2026]. [Online PDF]. Available at: [<https://www.benchchem.com/product/b2556321/docs#technical-guide-chromatographic-resolution-of-n-benzylated-indole-regioisomers-1>]

---

### Disclaimer & Data Validity:

The information provided in this document is for Research Use Only (RUO) and is strictly not intended for diagnostic or therapeutic procedures. While BenchChem strives to provide accurate protocols, we make no warranties, express or implied, regarding the fitness of this product for every specific experimental setup.

**Technical Support:** The protocols provided are for reference purposes. Unsure if this reagent suits your experiment?

**Need Industrial/Bulk Grade?** [Request Custom Synthesis Quote](#)

## BenchChem

Our mission is to be the trusted global source of essential and advanced chemicals, empowering scientists and researchers to drive progress in science and industry.

### Contact

Address: 3281 E Guasti Rd

Ontario, CA 91761, United States

Phone: (601) 213-4426

Email: [info@benchchem.com](mailto:info@benchchem.com)

[Contact our Ph.D. Support Team for a compatibility check](#)