

Confirming bridgehead fluorination via spectroscopic methods

Author: BenchChem Technical Support Team. **Date:** May 2026

Compound of Interest

Compound Name: 4-Fluorobicyclo[2.2.2]octane-1-carboxylic acid
CAS No.: 78385-84-9
Cat. No.: B2551965

[Get Quote](#)

Bridgehead Fluorination: A Spectroscopic Validation Guide

Executive Summary: The Regiochemical Challenge

In medicinal chemistry, bridgehead fluorination (e.g., on adamantane, bicyclo[1.1.1]pentane, or bicyclo[2.2.2]octane scaffolds) is a high-value strategy to modulate lipophilicity (LogD) and block metabolic soft spots without introducing significant steric bulk. However, the synthesis of these motifs often involves radical pathways or electrophilic fluorination (e.g., Selectfluor™) that can lead to isomeric mixtures (bridgehead vs. bridge).

The Core Problem: Standard LC-MS confirms the presence of fluorine (+18 Da mass shift) but is often "regio-blind." Distinguishing a tertiary bridgehead fluoride from a secondary bridge fluoride requires a rigorous spectroscopic workflow.

This guide outlines a self-validating analytical cascade, prioritizing solution-phase NMR (

, HOESY) as the primary method, backed by X-ray crystallography as the ultimate arbiter.

Comparative Analysis of Validation Methods

The following table contrasts the three primary modalities for confirming bridgehead substitution.

Feature	Method A: Multi-Nuclear NMR	Method B: X-Ray Crystallography	Method C: Mass Spectrometry
Primary Output	Connectivity & Spatial Proximity	Absolute 3D Structure	Molecular Weight
Regioselectivity	High (via -coupling & HOESY)	Definitive	Low (requires fragmentation analysis)
Sample State	Solution (Dynamic)	Solid Crystal (Static)	Gas Phase (Ionized)
Throughput	Medium (10–60 mins)	Low (Days to Weeks)	High (< 5 mins)
Limitations	Requires solubility; overlapping signals	Requires diffraction-quality crystal	Cannot easily distinguish isomers
Verdict	The Workhorse	The Gold Standard	The Quick Screen

The Analytical Workflow (Decision Matrix)

The following diagram illustrates the logical flow for confirming bridgehead fluorination.

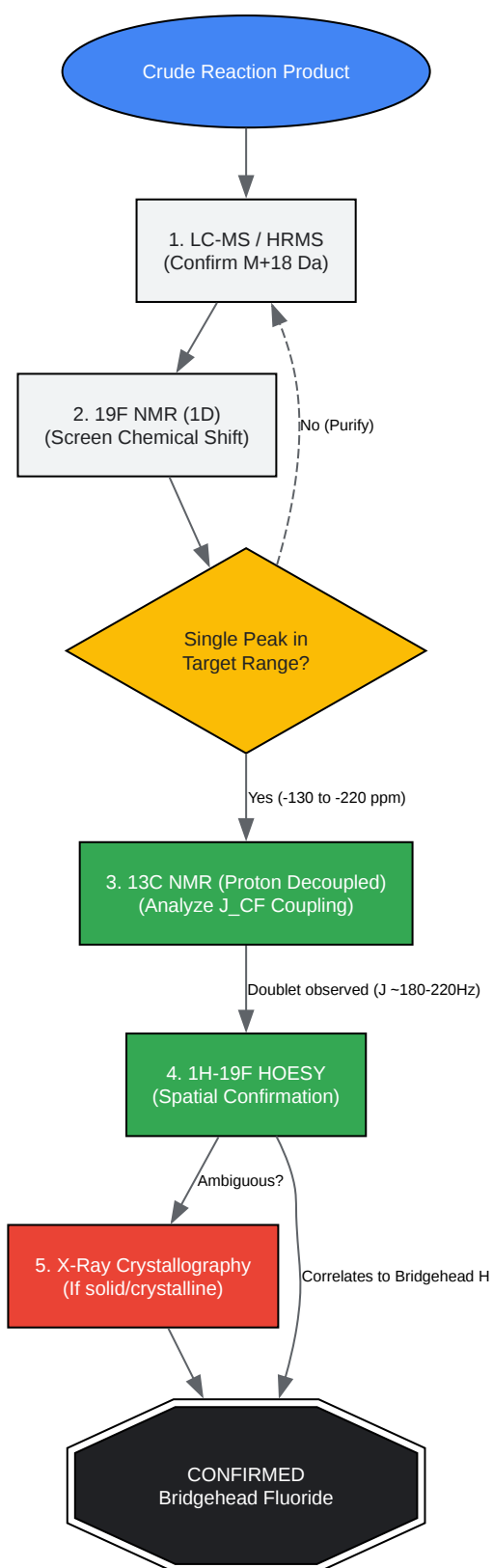

[Click to download full resolution via product page](#)

Figure 1: Step-by-step decision tree for validating bridgehead fluorination. Green nodes represent the critical NMR experiments.

Deep Dive: The NMR Validation Protocol

To scientifically prove the fluorine is at the bridgehead (tertiary carbon) and not a bridge (secondary carbon), you must exploit the spin properties of

(
, 100% abundance).

Step 1: Chemical Shift Screening

- Objective: Quick assessment of electronic environment.
- Expectation: Bridgehead fluorides (tertiary alkyl fluorides) typically resonate between -130 ppm and -220 ppm (referenced to).
- Note: This range overlaps with secondary fluorides, so chemical shift alone is insufficient for proof.

Step 2: NMR Splitting Patterns (The "Smoking Gun")

This is the most robust solution-phase check. You are looking for the One-Bond Coupling ().

- Mechanism: The nucleus will split the attached carbon signal into a doublet.
- The Diagnostic Signal:
 - Bridgehead (Tertiary C-F): You will see a doublet () with a large coupling constant, typically . Crucially, this carbon is quaternary in the

spectrum (if proton-decoupled) or has low intensity due to lack of NOE enhancement.

- Bridge (Secondary C-F): Also a doublet, but the neighboring carbons will show different symmetry and splitting patterns (

).

- Differentiation: In a bridgehead scenario (e.g., 1-fluoroadamantane), the symmetry often simplifies the spectrum. The

-carbon is a doublet, the

-carbons are doublets (

), and

-carbons are doublets (

).

Step 3: HOESY (Spatial Proximity)

Heteronuclear Overhauser Effect Spectroscopy (HOESY) measures through-space interactions, not through-bond.

- Logic: If F is at the bridgehead, it is spatially distant from the bridgehead protons of the same ring system but may show correlations to specific

-protons or adjacent substituents.

- Validation: If F were on a bridge (secondary), it would show a strong HOESY correlation to the geminal proton (if H and F are on the same carbon, though this is usually determined by

-coupling) or strong correlations to the immediate bridgehead protons.

Experimental Protocols

Protocol A: Quantitative Analysis

Standard

decouples protons but leaves fluorine coupling intact, which is desirable here.

- Sample Prep: Dissolve ~10-20 mg of compound in 0.6 mL

(or

-DMSO if polarity requires).
- Instrument: 400 MHz or higher (higher field improves sensitivity for quaternary carbons).
- Pulse Sequence: Standard zgpg30 (Bruker) or equivalent proton-decoupled carbon sequence.
- Parameters:
 - Relaxation Delay (D1): Set to 2–5 seconds. Fluorinated carbons can have long relaxation times.^[1]
 - Scans: Minimum 512 scans (due to splitting reducing peak height).
 - Spectral Width: Ensure -20 to 250 ppm to catch all carbons.
- Data Processing: Apply 1-2 Hz line broadening. Look for the doublet at the characteristic shift for the scaffold (e.g., adamantane bridgehead C is ~90 ppm). Measure the distance between peaks in Hz (value).

Protocol B: 1D HOESY

Use this for rapid confirmation of spatial proximity.^[2]

- Pulse Sequence: selhoesygp (Selective 1D HOESY).
- Excitation: Selectively irradiate the

signal (determine exact offset from 1D

spectrum).

- Mixing Time: 300–500 ms (allows magnetization transfer through space).
- Analysis: The resulting spectrum will only show protons physically close ($< 5 \text{ \AA}$) to the fluorine atom.
 - Bridgehead Confirmation: Absence of a geminal proton signal; presence of correlations to or
or
protons consistent with the 3D model.

Visualization of NMR Logic

The following diagram visualizes how the splitting confirms the structure.

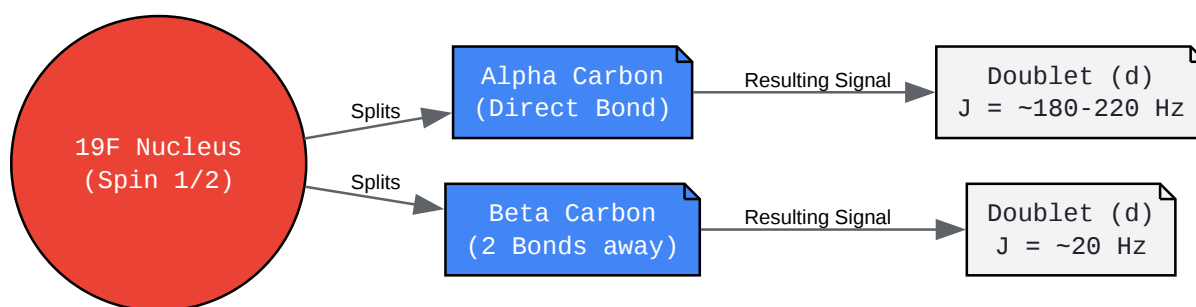

[Click to download full resolution via product page](#)

Figure 2: The propagation of spin-spin coupling from the Fluorine nucleus to the carbon skeleton.

References

- Dewis, L., et al. (2019).[3] "Improving the Accuracy of Internuclear Distance Measurement Using 2D HOESY." *Magnetic Resonance in Chemistry*. [Link](#)
- Reich, H. J. (2020).[4] "

NMR Chemical Shifts and Coupling Constants." University of Wisconsin-Madison Organic Chemistry Data. [Link](#)

- Claridge, T. D. W. (2016). High-Resolution NMR Techniques in Organic Chemistry. Elsevier. (Standard text for pulse sequences like HOESY).
- Vulpetti, A., et al. (2010).[5] "Combined use of computational chemistry, NMR screening, and X-ray crystallography for identification and characterization of fluorophilic protein environments." [5] Proteins. [5] [Link](#)
- UCSB NMR Facility. (n.d.). "

Chemical Shifts and Coupling Constants." University of California, Santa Barbara. [Link](#)

Need Custom Synthesis?

BenchChem offers custom synthesis for rare earth carbides and specific isotopic labeling.

Email: info@benchchem.com or [Request Quote Online](#).

Sources

- [1. 19Flourine NMR \[chem.ch.huji.ac.il\]](#)
- [2. Application for fluorine compounds | Applications Notes | JEOL Ltd. \[jeol.com\]](#)
- [3. Improving the accuracy of 1 H-19 F internuclear distance measurement using 2D 1 H-19 F HOESY - PubMed \[pubmed.ncbi.nlm.nih.gov\]](#)
- [4. organicchemistrydata.org \[organicchemistrydata.org\]](#)
- [5. Combined use of computational chemistry, NMR screening, and X-ray crystallography for identification and characterization of fluorophilic protein environments - PubMed \[pubmed.ncbi.nlm.nih.gov\]](#)
- To cite this document: BenchChem. [Confirming bridgehead fluorination via spectroscopic methods]. BenchChem, [2026]. [Online PDF]. Available at: [\[https://www.benchchem.com/product/b2551965/docs#confirming-bridgehead-fluorination-via-spectroscopic-methods\]](https://www.benchchem.com/product/b2551965/docs#confirming-bridgehead-fluorination-via-spectroscopic-methods)

Disclaimer & Data Validity:

The information provided in this document is for Research Use Only (RUO) and is strictly not intended for diagnostic or therapeutic procedures. While BenchChem strives to provide accurate protocols, we make no warranties, express or implied, regarding the fitness of this product for every specific experimental setup.

Technical Support: The protocols provided are for reference purposes. Unsure if this reagent suits your experiment?

Need Industrial/Bulk Grade? [Request Custom Synthesis Quote](#)

BenchChem

Our mission is to be the trusted global source of essential and advanced chemicals, empowering scientists and researchers to drive progress in science and industry.

Contact

Address: 3281 E Guasti Rd
Ontario, CA 91761, United States
Phone: (601) 213-4426
Email: info@benchchem.com

[Contact our Ph.D. Support Team for a compatibility check](#)