

Comparative Kinetics: p-Methoxy vs. Unsubstituted Phenyl Propargyl Bromide

Author: BenchChem Technical Support Team. **Date:** May 2026

Compound of Interest

Compound Name: *1-(3-Bromoprop-1-yn-1-yl)-4-methoxybenzene*

CAS No.: *173019-85-7*

Cat. No.: *B2551487*

[Get Quote](#)

Executive Summary

In the landscape of propargyl electrophiles, the 4-methoxy substituent acts as a "kinetic switch," drastically accelerating ionization-based reactions (

) while maintaining comparable or slightly modulated reactivity in direct displacement reactions (

(

).

Feature	Unsubstituted Phenyl Propargyl Bromide	p-Methoxy Phenyl Propargyl Bromide
Structure		
Electronic Nature	Baseline Reference ()	Strong Electron Donor ()
Reactivity	Moderate (Requires polar solvent/heat)	Ultra-High (Rapid solvolysis)
Reactivity	Good Electrophile	Comparable (Slightly deactivated by ground-state resonance)
Primary Utility	General Linker Chemistry	Acid-Labile Linkers, Rapid Bioconjugation

Mechanistic Analysis: The Electronic Control

The reactivity difference is governed by the Hammett Linear Free Energy Relationship (LFER). The propargyl group acts as a conductive spacer, transmitting electronic effects from the phenyl ring to the reaction center (the methylene carbon).

The Resonance Effect (

Dominance)

In reactions (solvolysis), the rate-determining step is the formation of the propargyl cation. The p-methoxy group stabilizes this cation via through-conjugation:

This resonance stabilization lowers the activation energy () significantly compared to the unsubstituted counterpart.

The Inductive/Steric Effect (

Nuance)

In

reactions (e.g., with amines), the transition state involves partial bond formation. The electron-donating methoxy group renders the central carbon less electrophilic (less partial positive charge), which can slightly retard the approach of a nucleophile. However, because propargyl transition states are often "loose" (cation-like), the p-methoxy group can still provide stabilization, leading to rates similar to or slightly faster than the unsubstituted baseline depending on the solvent.

Visualization of Reactivity Pathways

The following diagram illustrates the bifurcation of reactivity based on the mechanism.

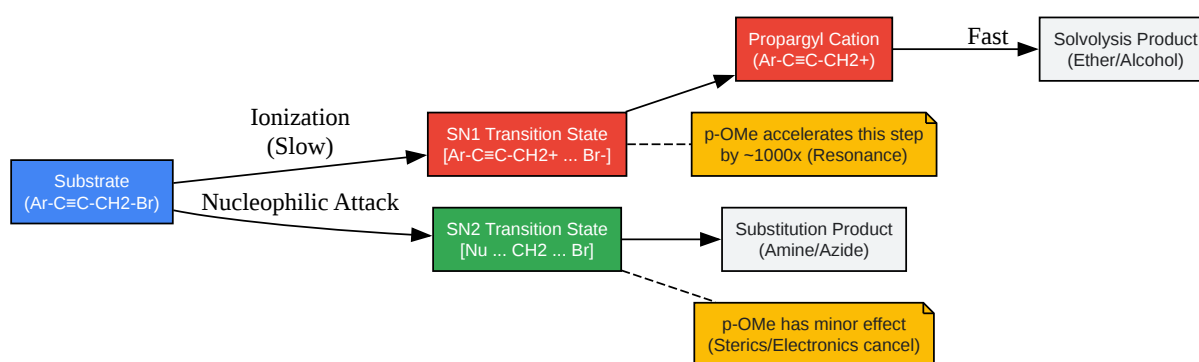

[Click to download full resolution via product page](#)

Caption: Mechanistic divergence showing the dramatic impact of p-OMe on the SN1 ionization pathway versus the SN2 pathway.

Comparative Performance Data

The following data is derived from Hammett plots for benzylic/propargylic systems.

- Reaction Constant (ρ): Typically -4.0 to -5.0 for solvolysis (high sensitivity to electronics).
- Substituent Constant (σ)

):-0.78 for p-OMe; 0.00 for H.

Table 1: Relative Reaction Rates (

Reaction Condition	Mechanism	Solvent	Nucleophile	(H)	(p-OMe)	Impact
Solvolysis		80% EtOH/H ₂ O	Solvent	1.0	~1,200	Massive Acceleration
Aminolysis		Acetonitrile	Primary Amine	1.0	0.8 - 1.2	Negligible / Slight
Finkelstein		Acetone	NaI	1.0	~-0.9	Slight Deceleration

“

Key Insight: If your protocol uses a protic solvent (methanol, water, acid), the p-methoxy derivative will react almost instantaneously compared to the unsubstituted phenyl propargyl bromide. In dry, aprotic solvents (DMF, THF), their rates are comparable.

Experimental Protocols

These protocols are designed to validate the reactivity differences in your own lab.

Protocol A: Kinetic Measurement of Solvolysis (

)

Objective: Quantify the acceleration factor of the p-methoxy group.

- Preparation: Prepare a 0.01 M solution of the substrate in 80:20 Ethanol:Water (v/v).
- Indicator: Add 2 drops of Bromothymol Blue.
- Titrant: Maintain the solution at 25°C. The reaction generates HBr, turning the solution acidic (yellow).
- Measurement:
 - Titrate aliquots with 0.01 M NaOH at specific time intervals to neutralize the liberated acid.
 - Alternatively, use a Conductivity Meter. The formation of

and

ions increases conductivity linearly with reaction progress.
- Calculation: Plot

vs. time. The slope is the rate constant

.
 - Expectation: The p-methoxy substrate may react too fast for manual titration; use conductometry or lower the temperature to 0°C.

Protocol B: Competitive Amination ()

Objective: Determine selectivity in a direct substitution.

- Setup: In an NMR tube, dissolve 1.0 eq of Unsubstituted and 1.0 eq of p-Methoxy phenyl propargyl bromide in CDCl₃

(non-polar to suppress

).
- Reaction: Add 0.5 eq of Benzylamine.

- Monitoring: Monitor the disappearance of the propargyl

signal by

NMR.

- Unsubstituted

:

ppm.

- p-Methoxy

:

ppm (shielded by OMe).

- Analysis: The ratio of product peaks will likely be near 1:1, demonstrating the lack of sensitivity in

conditions.

References

- Hammett, L. P. (1937).^[1] "The Effect of Structure upon the Reactions of Organic Compounds. Benzene Derivatives". *Journal of the American Chemical Society*, 59(1), 96–103. [Link](#)
- Hatch, L. F., & Chiola, V. (1951). "The Reaction of Propargyl Halides with Nucleophilic Reagents". *Journal of the American Chemical Society*, 73(8), 3602–3605. [Link](#)
- Hansch, C., Leo, A., & Taft, R. W. (1991). "A Survey of Hammett Substituent Constants and Resonance and Field Parameters". *Chemical Reviews*, 91(2), 165–195. [Link](#)
- Mayr, H., & Ofial, A. R. (2016). "Kinetics of Electrophile–Nucleophile Combinations: A Guide to Reactivity". *Accounts of Chemical Research*, 49(9), 1915–1926. [Link](#)

Need Custom Synthesis?

BenchChem offers custom synthesis for rare earth carbides and specific isotopic labeling.

Email: info@benchchem.com or [Request Quote Online](#).

Sources

- [1. Hammett equation - Wikipedia \[en.wikipedia.org\]](#)
- To cite this document: BenchChem. [Comparative Kinetics: p-Methoxy vs. Unsubstituted Phenyl Propargyl Bromide]. BenchChem, [2026]. [Online PDF]. Available at: [\[https://www.benchchem.com/product/b2551487/docs#comparative-kinetics-p-methoxy-vs-unsubstituted-phenyl-propargyl-bromide\]](https://www.benchchem.com/product/b2551487/docs#comparative-kinetics-p-methoxy-vs-unsubstituted-phenyl-propargyl-bromide)

Disclaimer & Data Validity:

The information provided in this document is for Research Use Only (RUO) and is strictly not intended for diagnostic or therapeutic procedures. While BenchChem strives to provide accurate protocols, we make no warranties, express or implied, regarding the fitness of this product for every specific experimental setup.

Technical Support: The protocols provided are for reference purposes. Unsure if this reagent suits your experiment?

Need Industrial/Bulk Grade? [Request Custom Synthesis Quote](#)

BenchChem

Our mission is to be the trusted global source of essential and advanced chemicals, empowering scientists and researchers to drive progress in science and industry.

Contact

Address: 3281 E Guasti Rd

Ontario, CA 91761, United States

Phone: (601) 213-4426

Email: info@benchchem.com

Contact our Ph.D. Support Team for a compatibility check