

# Tunicamycin V: A Comprehensive Guide for Unfolded Protein Response Studies

**Author:** BenchChem Technical Support Team. **Date:** April 2026

## Compound of Interest

Compound Name: Tunicamycin V

CAS No.: 66054-36-2

Cat. No.: B2550093

[Get Quote](#)

For researchers, scientists, and drug development professionals, inducing the Unfolded Protein Response (UPR) is a critical step in understanding cellular stress and its implications in various diseases. **Tunicamycin V** stands as a widely utilized and effective positive control for these studies. This guide provides an objective comparison of **Tunicamycin V** with other common UPR inducers, supported by experimental data and detailed protocols to ensure robust and reproducible results.

The Unfolded Protein Response is a cellular stress response pathway activated by an accumulation of unfolded or misfolded proteins in the endoplasmic reticulum (ER). This intricate signaling network aims to restore ER homeostasis but can trigger apoptosis if the stress is prolonged or severe. The UPR is mediated by three main ER transmembrane sensors: Inositol-requiring enzyme 1 (IRE1), PKR-like ER kinase (PERK), and Activating Transcription Factor 6 (ATF6).<sup>[1][2][3]</sup>

## Tunicamycin V: Mechanism of Action

**Tunicamycin V** is a nucleoside antibiotic that potently induces the UPR by inhibiting N-linked glycosylation, a crucial step in the proper folding of many proteins.<sup>[4]</sup> By blocking the enzyme

GlcNAc phosphotransferase (GPT), **Tunicamycin V** prevents the initial step of glycoprotein synthesis, leading to a global accumulation of unfolded glycoproteins in the ER and robust activation of all three UPR branches.[5]

## Comparison of UPR Inducers

**Tunicamycin V** is often the go-to positive control for UPR studies due to its broad and potent activity. However, other reagents with different mechanisms of action are also commonly used. Understanding their distinct effects is crucial for designing and interpreting experiments. The table below summarizes the key characteristics of **Tunicamycin V** and its common alternatives.

| Inducer              | Mechanism of Action   | Typical Working Concentration | Typical Incubation Time | Key Activated UPR Pathways                          |
|----------------------|---|-------------------------------|-------------------------|---|
| Tunicamycin V        | Inhibits N-linked glycosylation   | 2.5 - 10 µg/mL[6][7][8]       | 4 - 24 hours[9][10]     | IRE1, PERK, ATF6 (robustly activates all three)[11] |
| Thapsigargin         | Inhibits the Sarco/Endoplasmic Reticulum Ca <sup>2+</sup> -ATPase (SERCA) pump, leading to ER calcium depletion | 200 nM - 1 µM[6][8][10]       | 1 - 24 hours[1][9]      | IRE1, PERK, ATF6 (strong activator)[11]             |
| Dithiothreitol (DTT) | A reducing agent that prevents disulfide bond formation   | 1 - 2 mM[8][10]               | 2 - 16 hours[8][10]     | Primarily IRE1 and PERK[8]                          |
| Brefeldin A          | Inhibits protein transport from the ER to the Golgi apparatus   | 0.5 - 5 µg/mL                 | 6 - 24 hours            | Primarily ATF6[11]                                  |

# Signaling Pathways and Experimental Workflow

To visualize the complex interactions within the UPR and the general workflow of a typical experiment, the following diagrams are provided.

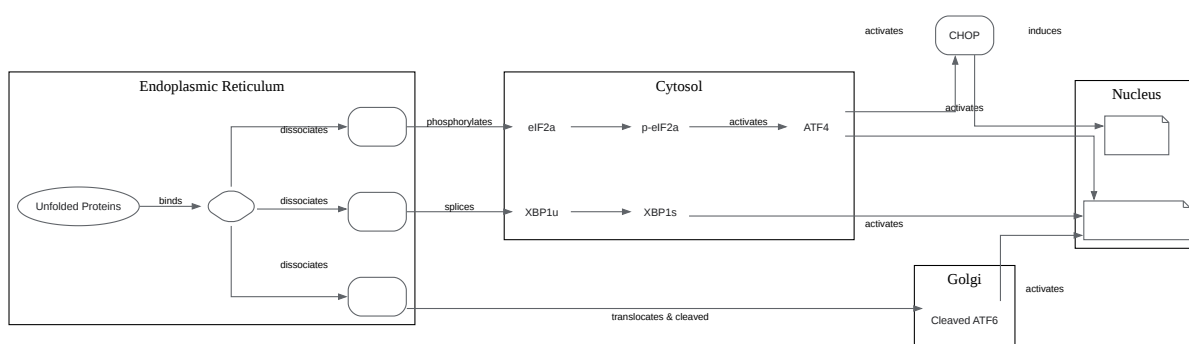

[Click to download full resolution via product page](#)

**Figure 1.** The Unfolded Protein Response Signaling Pathway.

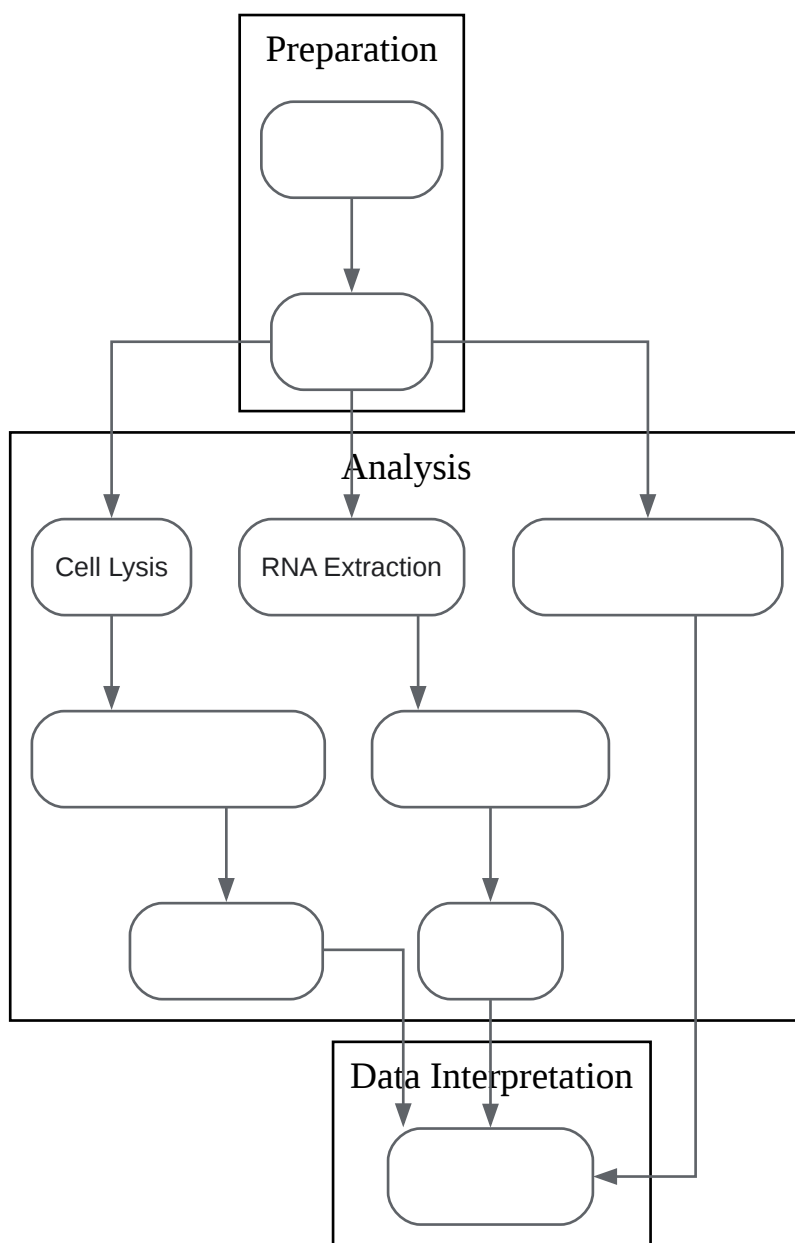

[Click to download full resolution via product page](#)

**Figure 2.** A typical experimental workflow for UPR studies.

## Experimental Protocols

### Western Blotting for UPR Markers (e.g., GRP78/BiP, CHOP)

This protocol outlines the detection of key UPR proteins to assess the activation of the response.

a. Sample Preparation:

- Seed cells in a 6-well plate and grow to 70-80% confluency.
- Treat cells with the desired UPR inducer (e.g., **Tunicamycin V** at 5 µg/mL) for the appropriate time (e.g., 16 hours). Include a vehicle-treated control.
- Wash cells twice with ice-cold PBS.
- Lyse cells in RIPA buffer supplemented with protease and phosphatase inhibitors.
- Centrifuge the lysate at 14,000 x g for 15 minutes at 4°C.
- Collect the supernatant and determine the protein concentration using a BCA assay.

b. SDS-PAGE and Transfer:

- Load 20-30 µg of protein per lane on an SDS-PAGE gel.
- Run the gel until the dye front reaches the bottom.
- Transfer the proteins to a PVDF or nitrocellulose membrane.[\[12\]](#)

c. Immunodetection:

- Block the membrane with 5% non-fat dry milk or BSA in TBST for 1 hour at room temperature.
- Incubate the membrane with primary antibodies against GRP78/BiP (1:1000) and CHOP (1:500) overnight at 4°C.[\[13\]](#)
- Wash the membrane three times with TBST for 10 minutes each.
- Incubate with HRP-conjugated secondary antibody (1:5000) for 1 hour at room temperature.
- Wash the membrane three times with TBST for 10 minutes each.

- Detect the signal using an enhanced chemiluminescence (ECL) substrate and image the blot.[14]

## Quantitative PCR (qPCR) for XBP1 Splicing and ATF4 Expression

This protocol allows for the quantification of UPR-induced gene expression changes.

### a. RNA Extraction and cDNA Synthesis:

- Treat cells as described in the Western Blotting protocol.
- Extract total RNA using a commercial kit according to the manufacturer's instructions.
- Assess RNA quality and quantity.
- Synthesize cDNA from 1 µg of total RNA using a reverse transcription kit.[5]

### b. qPCR:

- Prepare a qPCR reaction mix containing SYBR Green master mix, forward and reverse primers for XBP1s (spliced XBP1), total XBP1, ATF4, and a housekeeping gene (e.g., GAPDH or ACTB).[5][15]
- Perform the qPCR reaction using a real-time PCR system.
- Analyze the data using the  $\Delta\Delta C_t$  method to determine the relative fold change in gene expression. The ratio of spliced XBP1 to total XBP1 indicates the extent of IRE1 activation. [5][16]

## Cell Viability Assay (WST-1 or MTT)

This assay is used to assess the cytotoxic effects of UPR induction.

- Seed cells in a 96-well plate at an appropriate density.
- Treat cells with a range of concentrations of the UPR inducer for the desired time.

- Add WST-1 or MTT reagent to each well and incubate according to the manufacturer's protocol (typically 1-4 hours).[17]
- Measure the absorbance at the appropriate wavelength using a microplate reader.
- Calculate cell viability as a percentage of the vehicle-treated control.

## Conclusion

**Tunicamycin V** is a robust and reliable positive control for inducing a comprehensive unfolded protein response, activating all three major signaling branches. Its well-characterized mechanism of action and potent effects make it an invaluable tool for researchers. By understanding its performance in comparison to other UPR inducers and employing standardized, detailed experimental protocols, scientists can ensure the generation of high-quality, reproducible data in their investigations of ER stress and its role in health and disease.

### *Need Custom Synthesis?*

*BenchChem offers custom synthesis for rare earth carbides and specific isotopic labeling.*

*Email: [info@benchchem.com](mailto:info@benchchem.com) or [Request Quote Online](#).*

## References

- [1. Ire1 Has Distinct Catalytic Mechanisms for XBP1/HAC1 Splicing and RIDD - PMC \[pmc.ncbi.nlm.nih.gov\]](#)
- [2. researchgate.net \[researchgate.net\]](#)
- [3. discovery.researcher.life \[discovery.researcher.life\]](#)
- [4. Thapsigargin and Tunicamycin Block SARS-CoV-2 Entry into Host Cells via Differential Modulation of Unfolded Protein Response \(UPR\), AKT Signaling, and Apoptosis - PMC \[pmc.ncbi.nlm.nih.gov\]](#)
- [5. benchchem.com \[benchchem.com\]](#)
- [6. A multi-omics analysis reveals the unfolded protein response regulon and stress-induced resistance to folate-based antimetabolites - PMC \[pmc.ncbi.nlm.nih.gov\]](#)
- [7. Modeling Acute ER stress in vivo and in vitro - PMC \[pmc.ncbi.nlm.nih.gov\]](#)

- [8. molbiolcell.org \[molbiolcell.org\]](https://molbiolcell.org)
- [9. researchgate.net \[researchgate.net\]](https://researchgate.net)
- [10. Item - ER-stress induced by Thapsigargin, Tunicamycin or DTT is not attenuated by ALR. - Public Library of Science - Figshare \[plos.figshare.com\]](https://pubmed.ncbi.nlm.nih.gov/31111111/)
- [11. researchgate.net \[researchgate.net\]](https://researchgate.net)
- [12. 7tmantibodies.com \[7tmantibodies.com\]](https://7tmantibodies.com)
- [13. researchgate.net \[researchgate.net\]](https://researchgate.net)
- [14. Western Blot Protocols | Antibodies.com \[antibodies.com\]](https://antibodies.com)
- [15. Real-time PCR quantification of spliced X-box binding protein 1 \(XBP1\) using a universal primer method - PubMed \[pubmed.ncbi.nlm.nih.gov\]](https://pubmed.ncbi.nlm.nih.gov/26111111/)
- [16. researchgate.net \[researchgate.net\]](https://researchgate.net)
- [17. Cell Viability Assays - Assay Guidance Manual - NCBI Bookshelf \[ncbi.nlm.nih.gov\]](https://ncbi.nlm.nih.gov/pmc/books/CP000000000/)
- To cite this document: BenchChem. [Tunicamycin V: A Comprehensive Guide for Unfolded Protein Response Studies]. BenchChem, [2026]. [Online PDF]. Available at: [\[https://www.benchchem.com/product/b2550093/docs#tunicamycin-v-a-comprehensive-guide-for-unfolded-protein-response-studies\]](https://www.benchchem.com/product/b2550093/docs#tunicamycin-v-a-comprehensive-guide-for-unfolded-protein-response-studies)

---

### Disclaimer & Data Validity:

The information provided in this document is for Research Use Only (RUO) and is strictly not intended for diagnostic or therapeutic procedures. While BenchChem strives to provide accurate protocols, we make no warranties, express or implied, regarding the fitness of this product for every specific experimental setup.

**Technical Support:** The protocols provided are for reference purposes. Unsure if this reagent suits your experiment?

**Need Industrial/Bulk Grade?** [Request Custom Synthesis Quote](#)

# BenchChem

Our mission is to be the trusted global source of essential and advanced chemicals, empowering scientists and researchers to drive progress in science and industry.

## Contact

Address: 3281 E Guasti Rd

Ontario, CA 91761, United States

Phone: (601) 213-4426

Email: [info@benchchem.com](mailto:info@benchchem.com)

[Contact our Ph.D. Support Team for a compatibility check](#)