

# Technical Support Center: Improving Regioselectivity of Bromopyridine Synthesis

**Author:** BenchChem Technical Support Team. **Date:** May 2026

## Compound of Interest

Compound Name: 2-(3-Bromopyridin-4-yl)propan-1-ol

CAS No.: 2248405-68-5

Cat. No.: B2546527

[Get Quote](#)

Welcome to the technical support center for bromopyridine synthesis. This guide is designed for researchers, scientists, and professionals in drug development who are navigating the complexities of achieving regioselectivity in pyridine bromination. Here, we address common challenges and frequently asked questions, providing in-depth, field-proven insights to enhance the success of your experiments.

## Section 1: Frequently Asked Questions (FAQs)

This section tackles the fundamental principles and strategic decisions involved in controlling the position of bromine substitution on the pyridine ring.

### FAQ 1: Why is pyridine bromination so challenging, and what determines the "natural" regioselectivity?

Answer: The challenge arises from the inherent electronic properties of the pyridine ring. The nitrogen atom is highly electronegative, exerting a strong electron-withdrawing effect. This deactivates the entire ring towards electrophilic aromatic substitution (EAS) compared to

benzene.[1][2] Resonance structures show that this deactivation is most pronounced at the C2 (ortho) and C4 (para) positions, which develop a partial positive charge.

Consequently, electrophilic attack, such as with  $\text{Br}^+$ , preferentially occurs at the C3 (meta) position, which is the least deactivated site.[3][4][5] However, these reactions require harsh conditions (e.g., high temperatures, strong acids) due to the ring's low reactivity, which can lead to low yields and side reactions.[6][7]

Under strongly acidic conditions required for many EAS reactions, the pyridine nitrogen is protonated, forming the pyridinium ion. This further deactivates the ring, making substitution even more difficult.[8][9]

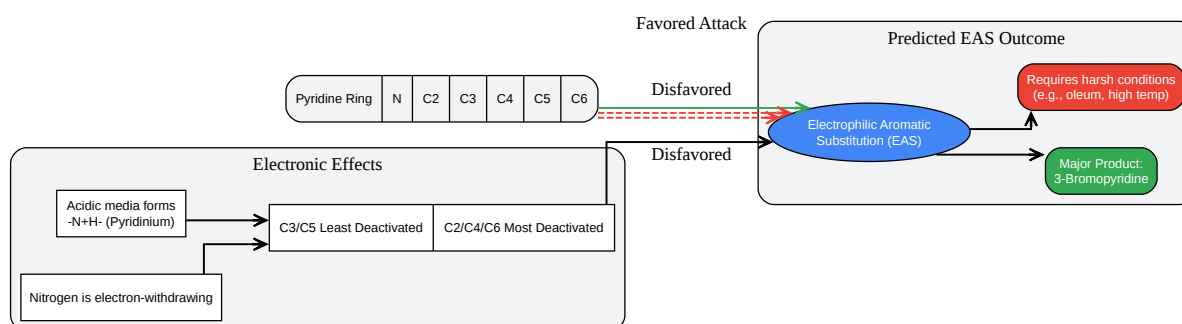

[Click to download full resolution via product page](#)

Caption: Inherent electronic properties of pyridine directing electrophilic attack.

## FAQ 2: How can I achieve bromination at the C3 and C5 positions?

Answer: Direct electrophilic bromination is the most straightforward method for accessing the C3 and C5 positions. Given the ring's deactivation, this typically requires forcing conditions. A

common and effective method involves heating pyridine with bromine in the presence of fuming sulfuric acid (oleum) or concentrated sulfuric acid at high temperatures (e.g., 130-140°C).[6][10][11] The  $\text{SO}_3$  in oleum acts as a Lewis acid, polarizing the Br-Br bond and increasing the electrophilicity of the bromine.

Key Experimental Considerations:

- Reagents: Molecular bromine ( $\text{Br}_2$ ) with oleum ( $\text{H}_2\text{SO}_4 \cdot \text{SO}_3$ ) or concentrated  $\text{H}_2\text{SO}_4$ . [10][11]
- Temperature: Typically high, in the range of 130-140°C. [11]
- Drawbacks: These are harsh conditions that may not be suitable for sensitive substrates. Yields can be moderate, and the process requires careful handling of corrosive materials. [10]

### FAQ 3: My target is a 2-bromo or 4-bromopyridine. How can I override the natural C3 selectivity?

Answer: To achieve substitution at the C2 or C4 positions, you must employ strategies that circumvent the rules of electrophilic aromatic substitution. The most common and reliable methods include:

- Synthesis from Aminopyridines (Sandmeyer Reaction): This is a classic and highly effective method, particularly for synthesizing 2-bromopyridines. [12][13] The process involves the diazotization of an aminopyridine (e.g., 2-aminopyridine) with a nitrite source (like  $\text{NaNO}_2$ ) in the presence of HBr to form a diazonium salt. This intermediate is then displaced by bromide, often with the aid of a copper(I) bromide ( $\text{CuBr}$ ) catalyst. [14][15]
  - Advantage: This method provides excellent and unambiguous regioselectivity. [12][13][16]
  - Applicability: Ideal for 2- and 4-bromopyridine synthesis starting from the corresponding aminopyridines.
- Using Pyridine N-Oxides: The N-oxide group is a powerful tool for altering the regioselectivity of pyridine. It activates the ring towards electrophilic substitution, particularly at the C4 position, by donating electron density through resonance. [17][18] After bromination at the C4-position, the N-oxide can be removed by reduction (e.g., with  $\text{PCl}_3$  or  $\text{PBr}_3$ ) to yield the 4-

bromopyridine.[17] Bromination at the C2 position of N-oxides can also be achieved under specific conditions.[19]

- Advantage: Enables access to C4-substituted pyridines under milder conditions than direct EAS on pyridine itself.[17][18]
- Directed ortho-Metalation (DoM): This strategy uses a directing group (DG) on the pyridine ring to deliver a strong base (typically an organolithium reagent like n-BuLi or LDA) to a specific ortho position. This deprotonation creates a potent nucleophilic organolithium species, which can then be quenched with an electrophilic bromine source (e.g., Br<sub>2</sub>, CBr<sub>4</sub>) to install bromine at the position adjacent to the DG. This is a powerful method for C2, C4, or C6 functionalization depending on the directing group's location.

## FAQ 4: What is the "Halogen Dance" reaction and when should I consider it?

Answer: The Halogen Dance is a base-catalyzed isomerization reaction where a halogen atom on an aromatic ring migrates to a different position.[20][21] This reaction typically occurs under strong basic conditions (e.g., LDA, KHMDS) at low temperatures.[20] It proceeds via a series of deprotonation and metal-halogen exchange steps, often driven by the formation of a more thermodynamically stable organometallic intermediate.[22]

When to Use It:

- Isomerization: If you have synthesized one bromopyridine isomer but require another that is more thermodynamically stable, the halogen dance can be a powerful tool. For example, it can be used to convert a 3-bromopyridine into a 4-substituted product.[21]
- Accessing Difficult Isomers: This reaction can provide a route to isomers that are not easily accessible through other means. Recent advancements have shown that continuous-flow reactors can improve control over these fast and often complex reactions.[20][23]

## Section 2: Troubleshooting Guide

This section addresses specific problems you might encounter during your experiments and provides actionable solutions.

## Problem 1: My electrophilic bromination of pyridine gives a very low yield or no reaction.

Possible Causes & Solutions:

- Cause: Insufficiently harsh conditions. Pyridine is highly deactivated.
  - Solution: Ensure your reaction temperature is high enough (e.g., >130°C).[11] If using H<sub>2</sub>SO<sub>4</sub>, consider switching to fuming sulfuric acid (oleum) to increase the reactivity of the brominating agent.[6]
- Cause: Protonation of pyridine. Under acidic conditions, the pyridine nitrogen is protonated, further deactivating the ring.[8]
  - Solution: While acid is necessary, ensure the conditions are optimized. The use of oleum helps to generate a more potent electrophile (Br<sup>+</sup> character) to overcome the deactivation. [6]
- Cause: Impure reagents. Water can interfere with the reaction, especially with oleum.
  - Solution: Use dry glassware and ensure your reagents are anhydrous.

## Problem 2: I am trying a Sandmeyer reaction to make 2-bromopyridine, but my yield is poor and I see many side products.

Possible Causes & Solutions:

- Cause: Unstable diazonium salt. Aryl diazonium salts can be unstable, especially at elevated temperatures.
  - Solution: Maintain a low temperature (typically 0°C or below) throughout the diazotization step.[12][13][24] Add the sodium nitrite solution slowly to control the exotherm.[12]
- Cause: Inefficient copper catalysis.

- Solution: Ensure you are using a fresh, active source of copper(I) bromide (CuBr). Some protocols benefit from a mixture of Cu(I) and Cu(II) salts.[25] The reaction is a radical-nucleophilic substitution, and the copper species is critical for the electron transfer steps. [14]
- Cause: Premature decomposition or side reactions of the diazonium intermediate.
  - Solution: Use the diazonium salt immediately after its formation. Do not let it sit for extended periods. The presence of excess bromide ions from HBr is crucial for trapping the intermediate effectively.[12]

### Problem 3: I am getting a mixture of regioisomers and can't isolate my desired product.

Possible Causes & Solutions:

- Cause: The chosen synthetic strategy lacks sufficient regiocontrol.
  - Solution: Re-evaluate your synthetic plan. If you need a single, pure isomer, a highly regioselective method is required.
    - For C3-bromo, direct EAS is often the best choice, but purification will be key.[10]
    - For C2-bromo, the Sandmeyer reaction starting from 2-aminopyridine is superior to other methods.[12][16]
    - For C4-bromo, bromination of pyridine N-oxide followed by deoxygenation is a highly reliable route.[17]

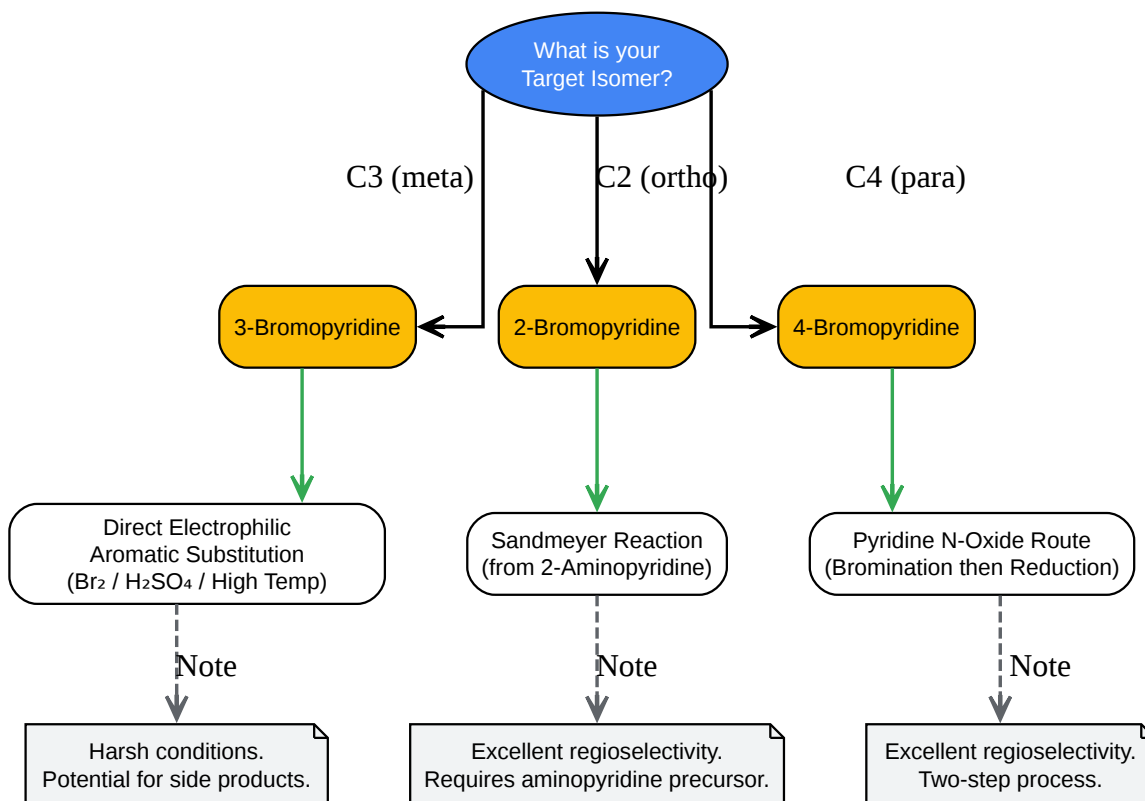

[Click to download full resolution via product page](#)

Caption: Decision workflow for selecting a bromination strategy.

## Section 3: Comparative Data & Protocols

### Table 1: Comparison of Key Bromination Strategies

| Strategy                            | Target Position(s)             | Key Reagents  | Pros  | Cons   |
|-------------------------------------|--------------------------------|---|---|--|
| Electrophilic Aromatic Substitution | C3, C5                         | Br <sub>2</sub> , H <sub>2</sub> SO <sub>4</sub> /Oleum                               | Direct, one-step process for C3.  | Harsh conditions, low-to-moderate yields, not suitable for sensitive substrates.[6][7] |
| Sandmeyer Reaction                  | C2, C4                         | Aminopyridine, NaNO <sub>2</sub> , HBr, CuBr  | Excellent, unambiguous regioselectivity. [12][14]                         | Requires aminopyridine starting material; diazonium intermediate can be unstable.[26]  |
| Pyridine N-Oxide Route              | C4 (primarily), C2             | Pyridine N-oxide, Brominating agent (e.g., PBr <sub>3</sub> ), then a reducing agent. | High regioselectivity for C4, milder conditions.[17][18]                  | Two-step process (oxidation then bromination/reduction).                               |
| Halogen Dance                       | Isomerization (e.g., C3 -> C4) | Bromopyridine, strong base (LDA, KHMDS)   | Access to thermodynamically favored isomers not easily made directly.[21] | Requires cryogenic temperatures, strong bases, and can be complex to control.[20]      |
| Transition Metal Catalysis          | Various (C-H Activation)       | Pyridine, Bromine source, Metal catalyst (e.g., Ru, Pd)                               | Can functionalize specific C-H bonds under milder conditions.[27][28][29] | Catalyst development is ongoing; substrate scope can be limited.                       |

## Experimental Protocol: Synthesis of 2-Bromopyridine via Sandmeyer Reaction

This protocol is adapted from established literature procedures and is provided for illustrative purposes.<sup>[12][13][16]</sup> All operations should be performed in a well-ventilated fume hood with appropriate personal protective equipment.

### Materials:

- 2-Aminopyridine
- 48% Hydrobromic acid (HBr)
- Bromine (Br<sub>2</sub>)
- Sodium nitrite (NaNO<sub>2</sub>)
- Sodium hydroxide (NaOH)
- Diethyl ether
- Anhydrous potassium hydroxide (KOH) or sodium sulfate (Na<sub>2</sub>SO<sub>4</sub>)
- 5 L three-necked flask, mechanical stirrer, dropping funnel, thermometer

### Procedure:

- **Flask Setup:** Equip a 5 L three-necked flask with a mechanical stirrer, a dropping funnel, and a low-temperature thermometer.
- **Initial Cooling:** Place 790 mL (7 moles) of 48% HBr into the flask and cool it to between -10°C and 0°C using an ice-salt bath.
- **Addition of 2-Aminopyridine:** While stirring, slowly add 150 g (1.59 moles) of 2-aminopyridine. Maintain the temperature below 0°C.
- **Bromine Addition:** Keeping the temperature at 0°C or lower, add 240 mL (4.7 moles) of bromine dropwise. The mixture may thicken as a yellow-orange perbromide forms.<sup>[12]</sup>

- **Diazotization:** Prepare a solution of 275 g (4 moles) of sodium nitrite in 400 mL of water. Add this solution dropwise over approximately 2 hours, ensuring the reaction temperature is strictly maintained at 0°C or below.<sup>[12]</sup> Vigorous stirring is essential.
- **Neutralization:** After the addition is complete, continue stirring for another 30 minutes. Then, slowly add a solution of 600 g (15 moles) of NaOH in 600 mL of water. Control the addition rate to keep the temperature below 25°C. The color of the mixture will lighten.<sup>[12]</sup>
- **Extraction:** Transfer the reaction mixture to a separatory funnel. Extract the aqueous layer with four 250 mL portions of diethyl ether. The layers may not separate easily.<sup>[12]</sup>
- **Drying and Distillation:** Combine the ether extracts and dry them over anhydrous KOH or Na<sub>2</sub>SO<sub>4</sub> for at least one hour. Filter, and remove the ether by simple distillation.
- **Purification:** Distill the remaining crude product under reduced pressure. Collect the fraction boiling at 74–75°C/13 mmHg to obtain pure 2-bromopyridine.<sup>[12]</sup>

## References

- Chempanda. (n.d.). Bromopyridine: Common isomorphs, synthesis, applications and storage. Chempanda. Retrieved from [\[Link\]](#)
- Organic Syntheses. (n.d.). 2-bromopyridine. Organic Syntheses Procedure. Retrieved from [\[Link\]](#)
- Patsnap. (2015, October 14). Synthetic method of 3-bromopyridine. Eureka. Retrieved from [\[Link\]](#)
- RSC Publishing. (n.d.). Unveiling the electrophilic aromatic substitution reactions of pyridine derivatives with nitronium ion through molecular electron density theory. New Journal of Chemistry. Retrieved from [\[Link\]](#)
- Blog. (2025, June 18). How to synthesize 4 - bromopyridine hydrochloride?. Retrieved from [\[Link\]](#)
- (n.d.). Mechanism and regioselectivity in an open-and-shut case of pyridine halogenation. Retrieved from [\[Link\]](#)

- ResearchGate. (n.d.). Continuous-flow halogen dance on 2-chloro-3-bromopyridine.[a] The same.... Retrieved from [[Link](#)]
- Kobe University. (2024, April 22). Ultrafast Halogen Dance Reactions of Bromoarenes Enabled by Catalytic Potassium Hexamethyldisilazide. Retrieved from [[Link](#)]
- Google Patents. (n.d.). CN104974081A - Synthetic method of 3-bromopyridine.
- Pearson. (2024, September 23). EAS Reactions of Pyridine: Videos & Practice Problems. Retrieved from [[Link](#)]
- Google Patents. (n.d.). CN104130183A - Synthetic method for 3-bromopyridine.
- Google Patents. (n.d.). CN104402805A - 2-bromopyridine synthesis method.
- Google Patents. (n.d.). US4291165A - Process for making 2-bromopyridine.
- Organic Chemistry Tutor. (n.d.). Electrophilic Aromatic Substitution in Heterocyclic Compounds. Retrieved from [[Link](#)]
- (n.d.). Electrophilic substitution on pyridine. Retrieved from [[Link](#)]
- Google Patents. (n.d.). CN103420905A - Synthetic method of 4-bromine-2,6-diaminopyridine.
- PubMed. (2021, November 19). Directing Group Enables Electrochemical Selectively Meta-Bromination of Pyridines under Mild Conditions. Retrieved from [[Link](#)]
- Who we serve. (2023, November 28). One-Flow Operation via 4-Bromopyridine Enables Flash Synthesis of AChE Inhibitor. Retrieved from [[Link](#)]
- Academia.edu. (n.d.). (PDF) Synthesis of bromocyclopropylpyridines via the Sandmeyer reaction. Retrieved from [[Link](#)]
- ResearchGate. (n.d.). ChemInform Abstract: Effective Lithiation of 3-Bromopyridine: Synthesis of 3-Pyridine Boronic Acid and Variously 3-Substituted Pyridines.. Retrieved from [[Link](#)]
- ResearchGate. (n.d.). Examples of halogen dance reactions and their catalysts.. Retrieved from [[Link](#)]

- Quora. (2019, October 9). Which position does Electrophilic aromatic substitution of Pyridine favour at?. Retrieved from [[Link](#)]
- PubMed. (2022, December 20). Continuous-Flow Divergent Lithiation of 2,3-Dihalopyridines: Deprotolithiation versus Halogen Dance. Retrieved from [[Link](#)]
- ResearchGate. (n.d.). Scheme 1. Transition-metal-catalyzed CH bromination.. Retrieved from [[Link](#)]
- YouTube. (2020, September 4). (L-448) Electrophilic aromatic substitution on Pyridine: Reaction mechanism and product selectivity.. Retrieved from [[Link](#)]
- PMC. (2021, August 20). Recent trends in the chemistry of Sandmeyer reaction: a review. Retrieved from [[Link](#)]
- Wikipedia. (n.d.). Sandmeyer reaction. Retrieved from [[Link](#)]
- ResearchGate. (n.d.). Regioselective bromination of pyridine N-oxide derivatives under... Download Scientific Diagram. Retrieved from [[Link](#)]
- RSC Publishing. (2020, September 9). Base-catalyzed aryl halide isomerization enables the 4-selective substitution of 3-bromopyridines. Chemical Science. DOI:10.1039/D0SC02689A. Retrieved from [[Link](#)]
- (2026, January 28). Direct and Chemoselective Bromination of Pyridines. Retrieved from [[Link](#)]
- The Journal of Organic Chemistry. (n.d.). Bromination of some pyridine and diazine N-oxides. Retrieved from [[Link](#)]
- ResearchGate. (n.d.). C-5 bromination of pyridine under transition metal-free protocol.. Retrieved from [[Link](#)]
- (2018, December 3). Reactions of Diazonium Salts: Sandmeyer and Related Reactions. Retrieved from [[Link](#)]

- PMC. (n.d.). Pyridine C(sp<sup>2</sup>)–H bond functionalization under transition-metal and rare earth metal catalysis. Retrieved from [[Link](#)]
- (n.d.). Heterocyclic Chemistry. Retrieved from [[Link](#)]
- (2022, June 17). (PDF) Pyridine Nucleus as a Directing Group for Metal-Based C-H Bond Activation. Retrieved from [[Link](#)]
- RSC Publishing. (n.d.). Transition-metal-free regioselective C–H halogenation of imidazo[1,2-a]pyridines: sodium chlorite/bromite as the halogen source. Retrieved from [[Link](#)]
- MDPI. (2021, July 23). Facile Synthesis and Characterization of a Bromine-Substituted (Chloromethyl)Pyridine Precursor towards the Immobilization of Biomimetic Metal Ion Chelates on Functionalized Carbons. Retrieved from [[Link](#)]
- PMC - NIH. (n.d.). An Efficient and Facile Methodology for Bromination of Pyrimidine and Purine Nucleosides with Sodium Monobromoisocyanurate (SMBI). Retrieved from [[Link](#)]
- Reddit. (2016, September 29). Can not get the selectivity of a aromatic bromination to behave, also low yielding. Am I just hosed here?. r/chemistry. Retrieved from [[Link](#)]
- (n.d.). Pyridine-catalyzed Halogenation of Aromatic Compounds. I. Bromination. Retrieved from [[Link](#)]

### Need Custom Synthesis?

BenchChem offers custom synthesis for rare earth carbides and specific isotopic labeling.

Email: [info@benchchem.com](mailto:info@benchchem.com) or [Request Quote Online](#).

## Sources

- 1. [organicchemistrytutor.com](https://organicchemistrytutor.com) [[organicchemistrytutor.com](https://organicchemistrytutor.com)]
- 2. [benchchem.com](https://benchchem.com) [[benchchem.com](https://benchchem.com)]
- 3. Electrophilic substitution on pyridine. [[quimicaorganica.org](https://quimicaorganica.org)]
- 4. [quora.com](https://quora.com) [[quora.com](https://quora.com)]

- [5. youtube.com \[youtube.com\]](https://www.youtube.com)
- [6. chempanda.com \[chempanda.com\]](https://chempanda.com)
- [7. Mechanism and regioselectivity in an open-and-shut case of pyridine halogenation - American Chemical Society \[acs.digitellinc.com\]](https://acs.digitellinc.com)
- [8. Unveiling the electrophilic aromatic substitution reactions of pyridine derivatives with nitronium ion through molecular electron density theory - New Journal of Chemistry \(RSC Publishing\) \[pubs.rsc.org\]](https://pubs.rsc.org)
- [9. pdf.benchchem.com \[pdf.benchchem.com\]](https://pdf.benchchem.com)
- [10. Synthetic method of 3-bromopyridine - Eureka | Patsnap \[eureka.patsnap.com\]](https://eureka.patsnap.com)
- [11. CN104974081A - Synthetic method of 3-bromopyridine - Google Patents \[patents.google.com\]](https://patents.google.com)
- [12. Organic Syntheses Procedure \[orgsyn.org\]](https://orgsyn.org)
- [13. 2-Bromopyridine synthesis - chemicalbook \[chemicalbook.com\]](https://chemicalbook.com)
- [14. Sandmeyer reaction - Wikipedia \[en.wikipedia.org\]](https://en.wikipedia.org)
- [15. masterorganicchemistry.com \[masterorganicchemistry.com\]](https://masterorganicchemistry.com)
- [16. US4291165A - Process for making 2-bromopyridine - Google Patents \[patents.google.com\]](https://patents.google.com)
- [17. huarongpharma.com \[huarongpharma.com\]](https://huarongpharma.com)
- [18. researchgate.net \[researchgate.net\]](https://researchgate.net)
- [19. Regioselective Bromination of Fused Pyridine N-Oxides | TCI AMERICA \[tcichemicals.com\]](https://tcichemicals.com)
- [20. researchgate.net \[researchgate.net\]](https://researchgate.net)
- [21. Base-catalyzed aryl halide isomerization enables the 4-selective substitution of 3-bromopyridines - Chemical Science \(RSC Publishing\) DOI:10.1039/D0SC02689A \[pubs.rsc.org\]](https://pubs.rsc.org)
- [22. webpages.iust.ac.ir \[webpages.iust.ac.ir\]](https://webpages.iust.ac.ir)
- [23. Continuous-Flow Divergent Lithiation of 2,3-Dihalopyridines: Deprotolithiation versus Halogen Dance - PubMed \[pubmed.ncbi.nlm.nih.gov\]](https://pubmed.ncbi.nlm.nih.gov)
- [24. CN104402805A - 2-bromopyridine synthesis method - Google Patents \[patents.google.com\]](https://patents.google.com)
- [25. Thieme E-Journals - Synthesis / Abstract \[thieme-connect.de\]](https://thieme-connect.de)

- [26. \(PDF\) Synthesis of bromocyclopropylpyridines via the Sandmeyer reaction \[academia.edu\]](#)
- [27. researchgate.net \[researchgate.net\]](#)
- [28. Pyridine C\(sp<sup>2</sup>\)–H bond functionalization under transition-metal and rare earth metal catalysis - PMC \[pmc.ncbi.nlm.nih.gov\]](#)
- [29. researchgate.net \[researchgate.net\]](#)
- To cite this document: BenchChem. [Technical Support Center: Improving Regioselectivity of Bromopyridine Synthesis]. BenchChem, [2026]. [Online PDF]. Available at: [\[https://www.benchchem.com/product/b2546527/docs#technical-support-center-improving-regioselectivity-of-bromopyridine-synthesis\]](https://www.benchchem.com/product/b2546527/docs#technical-support-center-improving-regioselectivity-of-bromopyridine-synthesis)

---

### Disclaimer & Data Validity:

The information provided in this document is for Research Use Only (RUO) and is strictly not intended for diagnostic or therapeutic procedures. While BenchChem strives to provide accurate protocols, we make no warranties, express or implied, regarding the fitness of this product for every specific experimental setup.

**Technical Support:** The protocols provided are for reference purposes. Unsure if this reagent suits your experiment?

**Need Industrial/Bulk Grade?** [Request Custom Synthesis Quote](#)

## BenchChem

Our mission is to be the trusted global source of essential and advanced chemicals, empowering scientists and researchers to drive progress in science and industry.

### Contact

Address: 3281 E Guasti Rd  
Ontario, CA 91761, United States  
Phone: (601) 213-4426  
Email: [info@benchchem.com](mailto:info@benchchem.com)

Contact our Ph.D. Support Team for a compatibility check