

Technical Support Center: Metabolic Stability of 7-Fluoro Substituted Spiro Compounds

Author: BenchChem Technical Support Team. **Date:** April 2026

Compound of Interest

Compound Name: *7-Fluoro-1H-spiro[indole-3,4'-oxane]-2-one*

CAS No.: 1695305-20-4

Cat. No.: B2545032

[Get Quote](#)

Welcome to the technical support center for researchers, scientists, and drug development professionals. This guide is designed to provide in-depth, practical advice and troubleshooting for experiments involving the metabolic stability of 7-fluoro substituted spiro compounds. My aim is to move beyond simple protocols and offer insights grounded in mechanistic principles and extensive field experience.

A Word from the Scientist

In drug discovery, achieving metabolic stability is a critical hurdle. Spirocyclic scaffolds are increasingly popular due to their unique three-dimensional structures, which can improve potency and selectivity while maintaining favorable physicochemical properties. However, these complex structures often present unique metabolic challenges. A common and effective strategy to enhance metabolic stability is the introduction of a fluorine atom, particularly at a metabolically vulnerable position.[1][2] The 7-fluoro substitution on a spiro core is a prime example of this "metabolic blocking" strategy.[3][4][5]

The rationale is straightforward: the carbon-fluorine bond is significantly stronger than a carbon-hydrogen bond, making it more resistant to oxidative metabolism by cytochrome P450 (CYP) enzymes, the primary drivers of Phase I drug metabolism.^{[1][6][7][8]} This guide will help you navigate the nuances of this strategy, from designing your experiments to interpreting complex results.

Part 1: Frequently Asked Questions (FAQs)

This section addresses common questions about the strategy and theory behind using 7-fluoro substitution to improve the metabolic stability of spiro compounds.

Q1: Why is the 7-position on a spirocyclic core often a target for fluorination?

The 7-position is frequently a "soft spot" for oxidative metabolism. Depending on the specific spiro scaffold, this position can be sterically accessible to the active sites of major metabolizing enzymes like CYP3A4.^[9] By replacing a hydrogen atom at this position with fluorine, you effectively "shield" this site from enzymatic attack.^{[2][3][4]} This modification can dramatically decrease the rate of metabolism, leading to a longer half-life and improved bioavailability.^[10]
^[11]

Q2: What is the primary mechanism by which fluorine improves metabolic stability?

The primary mechanism is the high strength of the C-F bond compared to the C-H bond.^[6] CYP-mediated oxidation typically involves the abstraction of a hydrogen atom. The high energy required to break the C-F bond makes this process far less favorable. Additionally, the high electronegativity of fluorine can deactivate adjacent positions on an aromatic ring, further reducing susceptibility to oxidation.^{[3][4]}

Q3: Besides blocking oxidation, are there other effects of adding a 7-fluoro group?

Yes, and it's crucial to consider these. Fluorine substitution can alter a molecule's physicochemical properties, such as lipophilicity and pKa.^{[2][12]} These changes can, in turn, affect solubility, membrane permeability, and binding affinity to the target protein.^[2] While often beneficial, it's a parameter that must be co-optimized with metabolic stability.

Q4: Which in vitro systems are best for assessing the metabolic stability of these compounds?

For early-stage discovery, liver microsomes are a cost-effective and high-throughput option to assess Phase I (CYP-mediated) metabolism.^{[11][13]} They contain a high concentration of CYP enzymes.^[11] However, for a more comprehensive picture that includes both Phase I and Phase II metabolism (e.g., glucuronidation), hepatocytes are considered the "gold standard" as they represent a more complete and physiologically relevant system.^{[11][14][15]}

Q5: Can 7-fluoro substitution lead to the formation of reactive metabolites?

While less common than with other halogens, it is a possibility that must be investigated. In some contexts, such as with fluoroanilines, metabolism at a fluorinated position can lead to the formation of reactive quinoneimine species.^{[16][17]} Therefore, if you observe unexpected toxicity or high levels of covalent binding, dedicated reactive metabolite screening assays are warranted.

Part 2: Troubleshooting Guide

This section is formatted to address specific problems you might encounter during your experiments, providing potential causes and actionable solutions.

Scenario 1: High In Vitro Clearance Persists Despite 7-Fluoro Substitution

Problem: You've introduced a 7-fluoro group to your parent spiro compound, but the intrinsic clearance (CL_{int}) in human liver microsomes (HLM) is still unacceptably high.

Possible Causes & Troubleshooting Steps:

- **Metabolism at an Alternative Site:** The 7-fluoro group may have successfully blocked one metabolic pathway, but the molecule is now being oxidized at a different, previously minor, "soft spot."
 - **Action:** Perform a "metabolite identification" (MetID) study. Incubate your compound with microsomes or hepatocytes for a longer duration or at a higher concentration and analyze the samples using high-resolution mass spectrometry. This will help identify the structures of the major metabolites and reveal the new site of metabolic attack.^[10]
- **Non-CYP Mediated Metabolism:** Your compound might be a substrate for other enzymes present in liver microsomes, such as Flavin-containing Monooxygenases (FMOs) or

Carboxylesterases (CES).

- Action: Conduct incubations with specific chemical inhibitors for different enzyme classes or use recombinant enzymes to pinpoint the responsible pathway.
- Chemical Instability: The compound may be degrading chemically in the incubation buffer, which can be mistaken for metabolic turnover.
 - Action: Always run a control incubation without the NADPH cofactor (for microsomes) or in heat-inactivated microsomes/hepatocytes.[18] If you still see disappearance of the parent compound, the issue is likely chemical instability.

Scenario 2: Excellent In Vitro Stability, but Poor In Vivo Pharmacokinetics (High Clearance)

Problem: Your 7-fluoro spiro compound shows very low clearance in both microsomes and hepatocytes, but when you dose it in an animal model (e.g., rat), it exhibits high plasma clearance and low exposure.

Possible Causes & Troubleshooting Steps:

- Extrahepatic Metabolism: Metabolism is not limited to the liver.[11] Other organs like the intestine, kidney, or lungs can contribute significantly to clearance.[11][19] Microsomes from these tissues can be used to investigate this.
 - Action: Perform metabolic stability assays using intestinal S9 fractions or kidney microsomes to assess the contribution of these organs to overall metabolism.
- Phase II Conjugation Dominance: The primary clearance mechanism in vivo might be direct conjugation (e.g., glucuronidation) of the parent molecule, which may not be fully captured in microsomal assays without specific cofactors.
 - Action: Ensure your hepatocyte assay is robust. If you suspect glucuronidation, you can also run microsomal assays supplemented with UDPGA, the necessary cofactor for UGT enzymes.[10]
- Active Transport / Biliary Excretion: The compound may be rapidly removed from circulation by transporters in the liver and excreted into the bile without being metabolized.

- Action: Use sandwich-cultured hepatocytes to study biliary efflux. This can provide an indication of whether your compound is a substrate for efflux transporters like P-gp or BCRP.
- Poor In Vitro-In Vivo Extrapolation (IVIVE): The correlation between in vitro stability and in vivo clearance can sometimes be weak.[20][21][22] This can be due to factors like high plasma protein binding or issues with the scaling factors used in predictive models.[21][23]
 - Action: Re-evaluate your IVIVE calculations. Ensure you are using accurate values for plasma protein binding. It's important to recognize that IVIVE is a predictive tool with inherent limitations.[23]

Part 3: Experimental Protocols & Data Visualization

To ensure reproducibility and accuracy, detailed protocols for key experiments are provided below.

Protocol 1: Liver Microsomal Stability Assay

This assay determines the rate of Phase I metabolism of a compound.[13]

Objective: To calculate the in vitro half-life ($t_{1/2}$) and intrinsic clearance (CL_{int}) of a test compound.

Materials:

- Pooled Human Liver Microsomes (HLM)
- Test compound and positive controls (e.g., Verapamil, Testosterone)
- 0.1 M Phosphate Buffer (pH 7.4)
- NADPH regenerating system (e.g., NADPH, glucose-6-phosphate, G6PDH)
- Acetonitrile with an internal standard (for quenching)
- 96-well plates

Step-by-Step Procedure:

- Preparation: Thaw liver microsomes on ice. Prepare working solutions of your test compound and controls in buffer.
- Pre-incubation: Add the liver microsomes and your test compound to the wells of a 96-well plate. Pre-incubate the plate at 37°C for 10 minutes to equilibrate the temperature.[24]
- Initiation: Start the metabolic reaction by adding the pre-warmed NADPH regenerating system to each well. This is your T=0 time point for the reaction kinetics.
- Time Points: At designated time points (e.g., 0, 5, 15, 30, 45 minutes), stop the reaction in specific wells by adding ice-cold acetonitrile containing an internal standard.[18]
- Sample Processing: Once all time points are collected, centrifuge the plate to pellet the precipitated protein.
- Analysis: Transfer the supernatant to a new plate for analysis by LC-MS/MS to quantify the remaining amount of the parent compound at each time point.
- Data Analysis: Plot the natural log of the percentage of compound remaining versus time. The slope of this line is used to calculate the half-life ($t_{1/2} = -0.693 / \text{slope}$). Intrinsic clearance (CL_{int}) is then calculated from the half-life.[10][13]

Data Presentation: Comparing Parent vs. 7-Fluoro Analog

The data below represents a typical outcome of a successful 7-fluoro substitution strategy.

Compound	$t_{1/2}$ in HLM (min)	CL _{int} (μL/min/mg protein)	In Vivo Clearance (Rat, mL/min/kg)
Parent Spiro	8	86.6	55
7-Fluoro Spiro	> 60	< 11.5	12

Table 1: Comparative metabolic stability and in vivo clearance data for a parent spiro compound and its 7-fluoro analog. Data is hypothetical but representative.

Part 4: Visualizing Workflows and Concepts

Diagrams can clarify complex experimental processes and theoretical concepts.

Diagram 1: Metabolic Blocking Strategy

This diagram illustrates the core concept of using 7-fluoro substitution to block a primary site of metabolic oxidation.

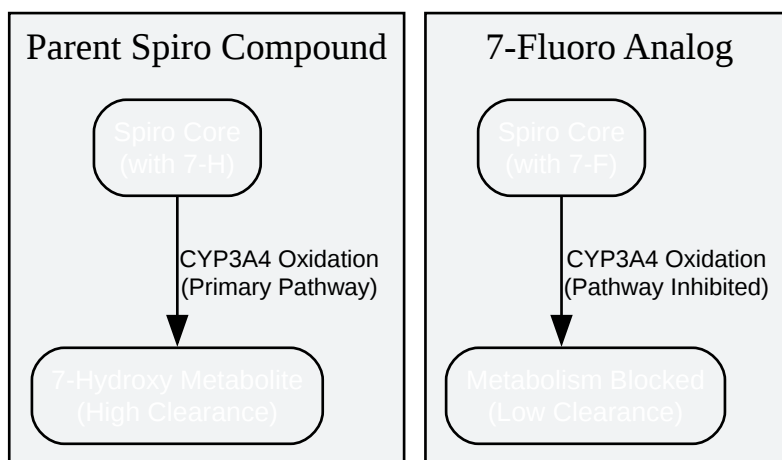

[Click to download full resolution via product page](#)

Caption: Blocking CYP450 oxidation with 7-fluoro substitution.

Diagram 2: Standard Microsomal Stability Assay Workflow

This diagram outlines the key steps in the experimental protocol described above.



[Click to download full resolution via product page](#)

Caption: Workflow for the in vitro liver microsomal stability assay.

References

- Advanced in vitro metabolic stability assays for drug discovery | CRO Services - Nuvisan. (n.d.). Retrieved from [\[Link\]](#)
- In vitro Metabolic Stability of Drugs and Applications of LC-MS in Metabolite Profiling. (2021, December 22). IntechOpen. Retrieved from [\[Link\]](#)
- The Role of Small Molecules Containing Fluorine Atoms - Encyclopedia.pub. (2024, February 27). Retrieved from [\[Link\]](#)
- In Vitro Metabolic Stability - Creative Bioarray. (n.d.). Retrieved from [\[Link\]](#)
- The Role of Small Molecules Containing Fluorine Atoms in Medicine and Imaging Applications - PMC. (n.d.). Retrieved from [\[Link\]](#)
- The role of fluorine in medicinal chemistry | Request PDF - ResearchGate. (n.d.). Retrieved from [\[Link\]](#)
- Introduction to in vitro estimation of metabolic stability and drug interactions of new chemical entities in drug discovery and development - PubMed. (2006, July 15). Retrieved from [\[Link\]](#)
- On the Metabolic Stability of Fluorinated Small Molecules: A Physical Organic Chemistry Perspective - PMC. (n.d.). Retrieved from [\[Link\]](#)
- Bioactivation of 4-fluorinated anilines to benzoquinoneimines as primary reaction products. (n.d.). Retrieved from [\[Link\]](#)
- Fluorine substituent effects (on bioactivity) - ResearchGate. (n.d.). Retrieved from [\[Link\]](#)
- Reaction Pathways for Biodehalogenation of Fluorinated Anilines - PubMed. (n.d.). Retrieved from [\[Link\]](#)
- Full article: The role of fluorine in medicinal chemistry. (2008, October 4). Retrieved from [\[Link\]](#)
- Containing Functional Groups & The Many Roles for Fluorine in Medicinal Chemistry. (n.d.).

- Metabolic Stability Assessed by Liver Microsomes and Hepatocytes | Springer Nature Experiments. (n.d.). Retrieved from [[Link](#)]
- Metabolism and Toxicity of Fluorine Compounds | Chemical Research in Toxicology. (2021, January 29). Retrieved from [[Link](#)]
- Microsomal stability assay for human and mouse liver microsomes - drug metabolism - Protocols.io. (2024, August 14). Retrieved from [[Link](#)]
- Protocol for the Human Liver Microsome Stability Assay - ResearchGate. (n.d.). Retrieved from [[Link](#)]
- Microsomal Clearance/Stability Assay - Domainex. (n.d.). Retrieved from [[Link](#)]
- Microsomal Stability | Cyprotex ADME-Tox Solutions | Evotec. (n.d.). Retrieved from [[Link](#)]
- Evaluating the effects of fluorine on biological properties and metabolic stability of some antitubulin 3-substituted 7-phenyl-pyrroloquinolinones - PubMed. (2019, September 15). Retrieved from [[Link](#)]
- Utility of metabolic stability screening: comparison of in vitro and in vivo clearance. (2008, September 22). Retrieved from [[Link](#)]
- Cytochrome P450-Mediated Metabolism and CYP Inhibition for the Synthetic Peroxide Antimalarial OZ439 - PMC. (n.d.). Retrieved from [[Link](#)]
- Investigating the Theoretical Basis for In Vitro-In Vivo Extrapolation (IVIVE) in Predicting Drug Metabolic Clearance and Proposing Future Experimental Pathways - PMC. (n.d.). Retrieved from [[Link](#)]
- Utility of metabolic stability screening: comparison of in vitro and in vivo clearance - PubMed. (2001, August 15). Retrieved from [[Link](#)]
- On the Metabolic Stability of Fluorinated Small Molecules; A Physical Organic Chemistry Perspective | ChemRxiv. (n.d.). Retrieved from [[Link](#)]

- On the Metabolic Stability of Fluorinated Small Molecules; A Physical Organic Chemistry Perspective - ChemRxiv. (n.d.). Retrieved from [[Link](#)]
- Examination of the Utility of the High Throughput In Vitro Metabolic Stability Assay to Estimate In Vivo Clearance in the Mouse. (2008, December 31). Retrieved from [[Link](#)]
- The Central Role of Cytochrome P450 in Xenobiotic Metabolism—A Brief Review on a Fascinating Enzyme Family - PMC. (n.d.). Retrieved from [[Link](#)]
- Hepatic Drug Metabolism and Cytochrome P450 - OpenAnesthesia. (2023, January 4). Retrieved from [[Link](#)]
- Decoding the Role of CYP450 Enzymes in Metabolism and Disease: A Comprehensive Review - MDPI. (2024, July 2). Retrieved from [[Link](#)]
- Cytochrome P450 Enzymes and Drug Metabolism in Humans - PMC - NIH. (n.d.). Retrieved from [[Link](#)]

Need Custom Synthesis?

BenchChem offers custom synthesis for rare earth carbides and specific isotopic labeling.

Email: info@benchchem.com or [Request Quote Online](#).

Sources

- 1. tandfonline.com [tandfonline.com]
- 2. gousei.f.u-tokyo.ac.jp [gousei.f.u-tokyo.ac.jp]
- 3. encyclopedia.pub [encyclopedia.pub]
- 4. The Role of Small Molecules Containing Fluorine Atoms in Medicine and Imaging Applications - PMC [[pmc.ncbi.nlm.nih.gov](https://pubmed.ncbi.nlm.nih.gov/)]
- 5. researchgate.net [researchgate.net]
- 6. On the Metabolic Stability of Fluorinated Small Molecules: A Physical Organic Chemistry Perspective - PMC [[pmc.ncbi.nlm.nih.gov](https://pubmed.ncbi.nlm.nih.gov/)]
- 7. openanesthesia.org [openanesthesia.org]

- [8. mdpi.com \[mdpi.com\]](#)
- [9. Cytochrome P450-Mediated Metabolism and CYP Inhibition for the Synthetic Peroxide Antimalarial OZ439 - PMC \[pmc.ncbi.nlm.nih.gov\]](#)
- [10. In vitro Metabolic Stability of Drugs and Applications of LC-MS in Metabolite Profiling | IntechOpen \[intechopen.com\]](#)
- [11. dda.creative-bioarray.com \[dda.creative-bioarray.com\]](#)
- [12. researchgate.net \[researchgate.net\]](#)
- [13. Microsomal Clearance/Stability Assay | Domainex \[domainex.co.uk\]](#)
- [14. nuvisan.com \[nuvisan.com\]](#)
- [15. Metabolic Stability Assessed by Liver Microsomes and Hepatocytes | Springer Nature Experiments \[experiments.springernature.com\]](#)
- [16. Bioactivation of 4-fluorinated anilines to benzoquinoneimines as primary reaction products - PubMed \[pubmed.ncbi.nlm.nih.gov\]](#)
- [17. Reaction pathways for biodehalogenation of fluorinated anilines - PubMed \[pubmed.ncbi.nlm.nih.gov\]](#)
- [18. Microsomal Stability | Cyprotex ADME-Tox Solutions | Evotec \[evotec.com\]](#)
- [19. labtesting.wuxiapptec.com \[labtesting.wuxiapptec.com\]](#)
- [20. tandfonline.com \[tandfonline.com\]](#)
- [21. Utility of metabolic stability screening: comparison of in vitro and in vivo clearance - PubMed \[pubmed.ncbi.nlm.nih.gov\]](#)
- [22. benthamopen.com \[benthamopen.com\]](#)
- [23. Investigating the Theoretical Basis for In Vitro-In Vivo Extrapolation \(IVIVE\) in Predicting Drug Metabolic Clearance and Proposing Future Experimental Pathways - PMC \[pmc.ncbi.nlm.nih.gov\]](#)
- [24. protocols.io \[protocols.io\]](#)
- To cite this document: BenchChem. [Technical Support Center: Metabolic Stability of 7-Fluoro Substituted Spiro Compounds]. BenchChem, [2026]. [Online PDF]. Available at: [https://www.benchchem.com/product/b2545032/docs#technical-support-center-metabolic-stability-of-7-fluoro-substituted-spiro-compounds]

Disclaimer & Data Validity:

The information provided in this document is for Research Use Only (RUO) and is strictly not intended for diagnostic or therapeutic procedures. While BenchChem strives to provide accurate protocols, we make no warranties, express or implied, regarding the fitness of this product for every specific experimental setup.

Technical Support: The protocols provided are for reference purposes. Unsure if this reagent suits your experiment?

Need Industrial/Bulk Grade? [Request Custom Synthesis Quote](#)

BenchChem

Our mission is to be the trusted global source of essential and advanced chemicals, empowering scientists and researchers to drive progress in science and industry.

Contact

Address: 3281 E Guasti Rd
Ontario, CA 91761, United States
Phone: (601) 213-4426
Email: info@benchchem.com

[Contact our Ph.D. Support Team for a compatibility check](#)