

Validating Purity of Sulfone Intermediates for Cross-Coupling: A Comparative Guide

Author: BenchChem Technical Support Team. **Date:** April 2026

Compound of Interest

Compound Name: *1-[(4-Bromophenyl)sulfonyl]-2-phenyl-2-propanol*

CAS No.: 338774-86-0

Cat. No.: B2543375

[Get Quote](#)

Introduction: The "Silent Killer" in Cross-Coupling

In modern drug discovery, sulfones are no longer just temporary auxiliaries for Julia-Kocienski olefinations; they are increasingly utilized as electrophilic partners in desulfitative cross-couplings (Suzuki, Negishi, Kumada type). However, the synthesis of sulfones—often via oxidation of sulfides—introduces a critical risk: trace sulfur impurities.

Unreacted sulfides, thiols, or partially oxidized sulfoxides are potent poisons for transition metal catalysts (Pd, Ni, Pt). A sulfone intermediate that appears "clean" by standard HPLC (99+ Area%) can stall a catalytic cycle if it contains even ppm-levels of high-affinity sulfur ligands. Furthermore, the stoichiometry of cross-coupling is unforgiving; a 5% mass error due to solvation or inorganic salts can lead to incomplete conversion and difficult purifications.

This guide objectively compares validation methods to ensure your sulfone intermediates are not just "chemically pure," but "catalyst-ready."

Comparative Analysis of Validation Methods

We evaluated three primary methodologies for validating sulfone purity. The data below summarizes their performance in a drug discovery context.

Table 1: Method Performance Matrix

Feature	Method A: HPLC-UV/MS	Method B: Quantitative NMR (qNMR)	Method C: Functional Stress Test
Primary Output	Relative Purity (Area %)	Absolute Purity (Weight %)	Catalyst Compatibility (Pass/Fail)
Detection Principle	UV Absorbance / Ionization	Nuclear Spin (Proton counting)	Reaction Kinetics
Blind Spot	Non-chromophoric impurities (salts, water), Response Factor errors.	Paramagnetic impurities, overlapping signals.	Does not identify what the impurity is.
Catalyst Sensitivity	Low (Cannot detect trace poisons easily).	Low (unless specific shift known).	High (Directly measures poisoning).
Setup Time	High (Method development required).	Low (< 15 mins).	High (Reaction set up).
Recommendation	Routine QC only.	Gold Standard for Stoichiometry.	Critical for Scale-up.

In-Depth Technical Assessment

Method A: HPLC-UV/MS (The Deceptive Standard)

While indispensable for identifying specific organic impurities, HPLC is often misleading for sulfones.

- **The Chromophore Problem:** Alkyl sulfones often lack strong UV chromophores, requiring low-wavelength detection (205-210 nm) where solvent noise is high.
- **Response Factors:** The oxidation of a sulfide to a sulfone changes the extinction coefficient (

). If the sulfide precursor has a higher

than the product, a 1% impurity can look like 10%, or vice versa.

- The Salt Trap: Sulfones are often isolated via precipitation. HPLC "Area %" ignores inorganic salts (e.g., sodium periodate byproducts) and retained solvent, leading to gross errors in molecular weight calculations for downstream coupling.

Method B: qNMR (The Absolute Standard)

qNMR is the most robust method for validating sulfone intermediates because it measures molar purity directly against an internal standard.

- Causality: Since signal integration is proportional to the number of nuclei, qNMR eliminates the need for compound-specific reference standards.
- Stoichiometry Control: It accounts for invisible impurities (water, salts, silica grease), ensuring that when you calculate 1.0 equivalents for a cross-coupling reaction, you actually add 1.0 equivalents.

Method C: Functional "Stress Test" (The Catalyst Safety Valve)

Analytical purity does not equal catalytic compatibility. A "Stress Test" involves spiking a standard, robust cross-coupling reaction with the sulfone intermediate to observe if the reaction rate is suppressed. This is the only way to detect trace catalyst poisons (e.g., metal-scavenging thioethers) that fall below the LOD of NMR or HPLC.

Experimental Protocols

Protocol 1: High-Precision qNMR for Sulfones

Objective: Determine absolute weight % purity to $\pm 1\%$ accuracy.

Reagents:

- Internal Standard (IS): 1,3,5-Trimethoxybenzene (High solubility, distinct singlet at ~ 6.1 ppm) or Maleic Acid (Singlet at ~ 6.3 ppm). Note: Avoid Dimethyl Sulfone as IS if analyzing alkyl sulfones to prevent overlap.

- Solvent: CDCl_3 or DMSO-d_6 (High quality, 99.8% D).

Workflow:

- Weighing: Accurately weigh ~10 mg of the Sulfone Sample () and ~5 mg of Internal Standard () into the same vial. Record weights to 0.01 mg precision.
- Dissolution: Add 0.6 mL deuterated solvent. Ensure complete dissolution (sonicate if necessary).
- Acquisition (Critical Parameters):
 - Pulse Angle: 90° (maximize signal).
 - Relaxation Delay (d1): Set to of the slowest relaxing proton (typically 30–60 seconds). Standard 1s delays will underestimate purity due to incomplete relaxation.
 - Scans: 16–32 scans for sufficient S/N ratio (>250:1).
- Processing: Phase and baseline correct manually. Integrate the IS peak (calibrate to known H count) and a distinct Sulfone peak.
- Calculation:

Where

=Integral,

=Number of protons,

=Molecular Weight,

=Purity of Internal Standard.

Protocol 2: The "Catalyst Poisoning" Stress Test

Objective: Detect trace sulfur impurities that kill Pd/Ni catalysts.

Concept: Run a "standard" easy reaction. If the addition of your sulfone stops it, your sulfone is dirty.

Workflow:

- Control Reaction: Set up a standard Suzuki coupling: 4-Bromoanisole (1.0 eq), Phenylboronic acid (1.2 eq), (2.0 eq), and (0.5 mol%) in Dioxane/Water.
- Spike: In a parallel vial, set up the exact same reaction but add 10 mol% of your Sulfone Intermediate.
- Monitor: Check conversion by LCMS or GCMS at 1 hour.
- Interpretation:
 - Control: >90% conversion.
 - Spike: >85% conversion
PASS. (Sulfone is safe).
 - Spike: <20% conversion
FAIL. (Sulfone contains catalyst poisons, likely unoxidized sulfides. Recrystallize or treat with scavengers).

Visualization & Logic

Diagram 1: Purity Validation Decision Matrix

This logic flow ensures you select the correct validation method based on downstream application risks.

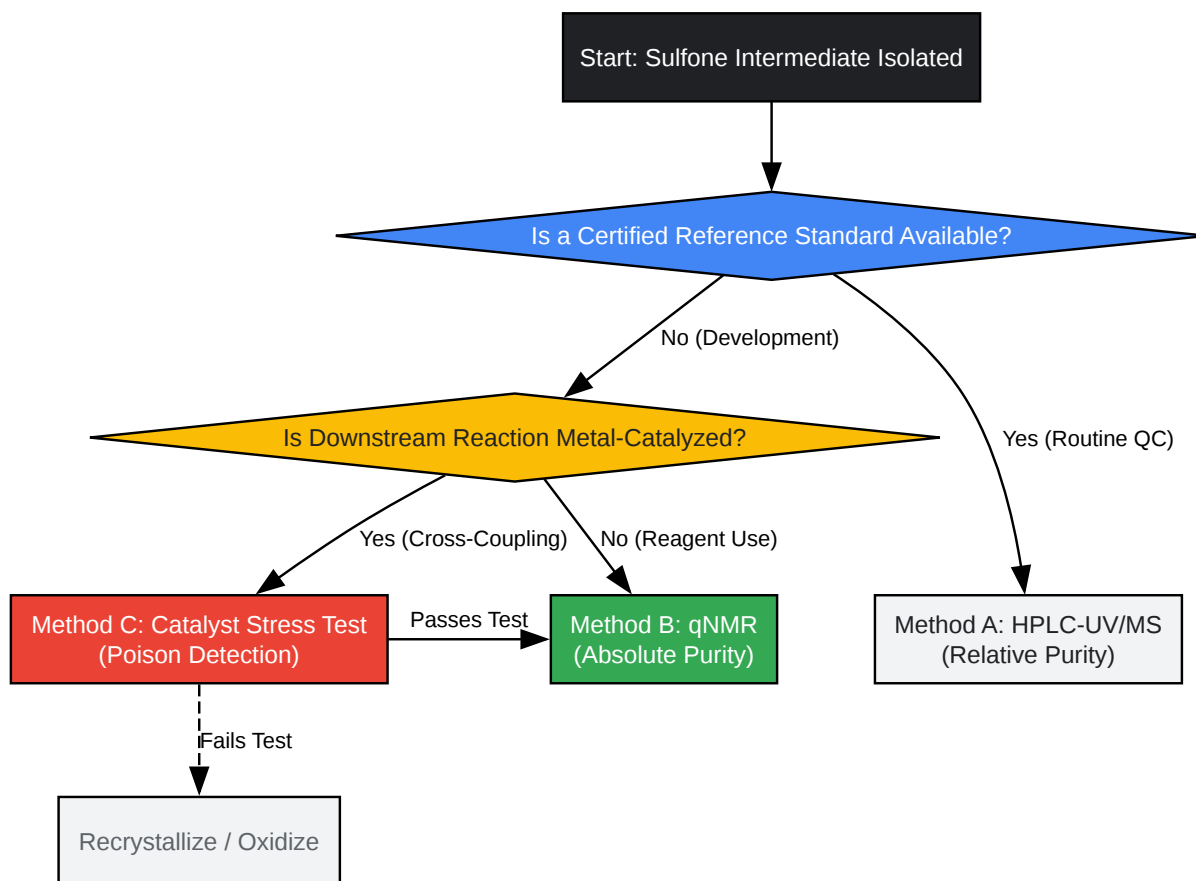

[Click to download full resolution via product page](#)

Caption: Decision matrix for selecting the appropriate purity validation method based on reference availability and downstream catalytic sensitivity.

Diagram 2: Mechanism of Failure vs. Success

Understanding why purity matters: The competition between productive coupling and catalyst poisoning.

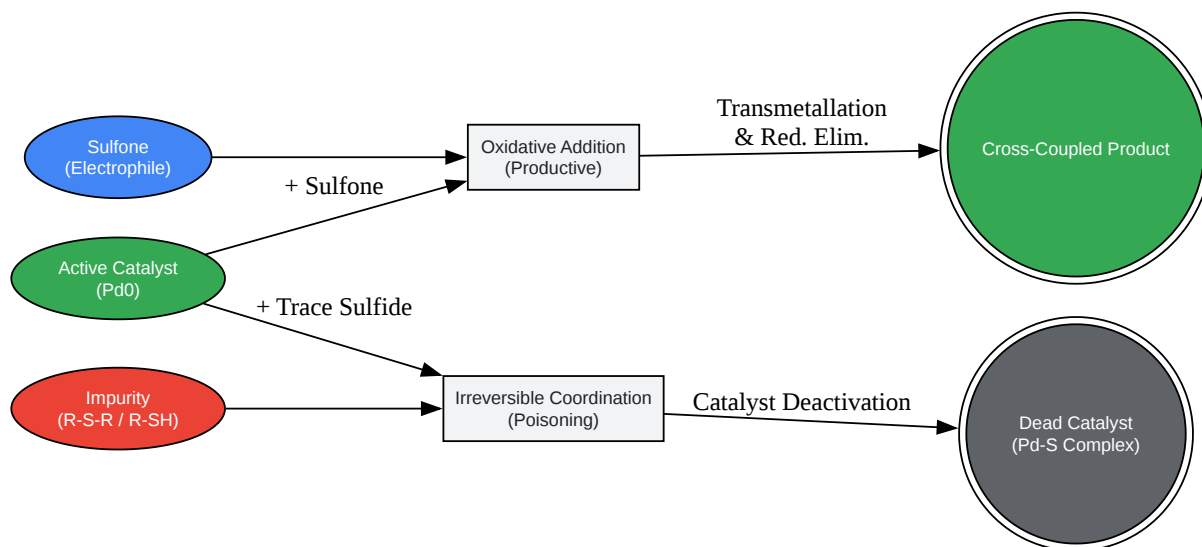

[Click to download full resolution via product page](#)

Caption: Mechanistic pathway showing how trace sulfur impurities (red path) outcompete the desired sulfone oxidative addition (blue path) by irreversibly binding the catalyst.

References

- BIPM. (2018). Internal Standard Reference Data for qNMR: Dimethyl sulfone. Bureau International des Poids et Mesures. [\[Link\]](#)
- Almac Group. (2020). Quantitative NMR (qNMR) as an Alternative to HPLC Assay Analysis. Almac Voice. [\[Link\]](#)
- Nambo, M., & Crudden, C. M. (2021).^[1] Transition Metal-Catalyzed Cross-Couplings of Benzylic Sulfone Derivatives. The Chemical Record. [\[Link\]](#)
- Merchant, R. R., et al. (2018). Modular radical cross-coupling with sulfones enables access to sp³-rich (fluoro)alkylated scaffolds. Science. [\[Link\]](#)

- Dunetz, J. R., Magano, J., & Weisenburger, G. A. (2016). Large-Scale Applications of Amide Coupling Reagents for the Synthesis of Pharmaceuticals. *Organic Process Research & Development*. (Context on impurity impacts in process). [[Link](#)]

Need Custom Synthesis?

BenchChem offers custom synthesis for rare earth carbides and specific isotopic labeling.

Email: info@benchchem.com or [Request Quote Online](#).

Sources

- 1. Transition Metal-Catalyzed Cross-Couplings of Benzylic Sulfone Derivatives - PubMed [pubmed.ncbi.nlm.nih.gov]
- To cite this document: BenchChem. [Validating Purity of Sulfone Intermediates for Cross-Coupling: A Comparative Guide]. BenchChem, [2026]. [Online PDF]. Available at: [<https://www.benchchem.com/product/b2543375/docs#validating-purity-of-sulfone-intermediates-for-cross-coupling-a-comparative-guide>]

Disclaimer & Data Validity:

The information provided in this document is for Research Use Only (RUO) and is strictly not intended for diagnostic or therapeutic procedures. While BenchChem strives to provide accurate protocols, we make no warranties, express or implied, regarding the fitness of this product for every specific experimental setup.

Technical Support: The protocols provided are for reference purposes. Unsure if this reagent suits your experiment?

Need Industrial/Bulk Grade? [Request Custom Synthesis Quote](#)

BenchChem

Our mission is to be the trusted global source of essential and advanced chemicals, empowering scientists and researchers to drive progress in science and industry.

Contact

Address: 3281 E Guasti Rd

Ontario, CA 91761, United States

Phone: (601) 213-4426

Email: info@benchchem.com

[Contact our Ph.D. Support Team for a compatibility check](#)