

# Technical Support Center: Managing Almonertinib Toxicity in Animal Models

**Author:** BenchChem Technical Support Team. **Date:** April 2026

## Compound of Interest

Compound Name: *Almonertinib hydrochloride*

Cat. No.: *B2543745*

[Get Quote](#)

This technical support center provides researchers, scientists, and drug development professionals with comprehensive troubleshooting guides and frequently asked questions (FAQs) for managing toxicities associated with Almonertinib in animal models.

## Frequently Asked Questions (FAQs)

Q1: What is Almonertinib and what is its mechanism of action?

A1: Almonertinib (HS-10296) is a third-generation Epidermal Growth Factor Receptor (EGFR) tyrosine kinase inhibitor (TKI).[1] It is designed to selectively target EGFR-sensitizing mutations and the T790M resistance mutation, with reduced activity against wild-type EGFR.[1][2] By irreversibly binding to the kinase domain of the mutant EGFR, Almonertinib blocks downstream signaling pathways that are crucial for cancer cell proliferation and survival.[1][2]

Q2: What are the most common toxicities observed with Almonertinib in animal models?

A2: Based on clinical data and the known class effects of EGFR inhibitors, the most anticipated toxicities in animal models would primarily affect tissues with high EGFR expression. These include:

- Dermatological: Skin rash (papulopustular) and pruritus (itching).[3]
- Gastrointestinal: Diarrhea, nausea, and vomiting.[3]
- Biochemical Abnormalities: Increased blood creatine phosphokinase and elevated liver transaminases (alanine aminotransferase - ALT).[4][5]
- General: Fatigue and decreased appetite.

Q3: How should I monitor for Almonertinib-induced toxicity in my animal studies?

A3: A robust monitoring plan is essential for the early detection and management of toxicities. We recommend the following:

- Daily Clinical Observations: Record body weight, food and water intake, and general appearance (e.g., posture, activity, grooming).[6]
- Dermatological Assessment: Implement a standardized scoring system to quantify the severity of skin rash.[6]
- Gastrointestinal Monitoring: Note the consistency and frequency of feces to detect and grade diarrhea.[6][7]
- Regular Blood Work: Conduct periodic blood sampling for complete blood counts (CBC) and serum chemistry panels to monitor for changes in liver enzymes, creatine phosphokinase, and kidney function.[6]

Q4: Is there a known Maximum Tolerated Dose (MTD) for Almonertinib in common animal models?

A4: Publicly available preclinical studies explicitly detailing the Maximum Tolerated Dose (MTD) of Almonertinib in rodent models like mice and rats are limited. However, a Phase 1 clinical trial in humans explored doses ranging from 55 mg to 260 mg daily.[5] The 260 mg dose was not further evaluated due to safety concerns and exposure saturation, suggesting that a dose-limiting toxicity threshold was being approached.[4][5] Dose-range finding studies are crucial to establish the MTD in your specific animal model and experimental conditions.[8][9]

## Troubleshooting Guides

### Problem 1: Animal exhibits significant skin rash and pruritus.

- Potential Cause: Inhibition of EGFR signaling in the skin disrupts the normal growth and function of keratinocytes, leading to an inflammatory response.[10]
- Troubleshooting Steps:
  - Dose Reduction/Interruption: Consider a temporary halt in dosing or a dose reduction to allow for skin recovery.[6]
  - Supportive Care: Apply a thin layer of a veterinary-approved, non-medicated emollient to the affected areas to maintain skin hydration.[11]
  - Environmental Enrichment: Provide enrichment to reduce stress-related scratching.[6]
  - Histopathological Analysis: At the end of the study, collect skin biopsies for histological examination to characterize the nature and severity of the dermatitis.[6]

### Problem 2: Animal develops moderate to severe diarrhea.

- Potential Cause: EGFR inhibition in the gastrointestinal tract can disrupt mucosal integrity and alter electrolyte and water absorption, leading to diarrhea.[12][13]
- Troubleshooting Steps:
  - Dose Adjustment: Temporarily suspend dosing or reduce the dose of Almonertinib.[6]
  - Supportive Care: Ensure ad libitum access to water and consider providing a supplementary hydration source like a hydrogel pack or electrolyte solution to prevent dehydration.[14] Monitor body weight daily; if weight loss exceeds 15%, consider subcutaneous fluid administration.[14]
  - Anti-diarrheal Medication: The use of loperamide can be considered to slow intestinal motility. Consult with a veterinarian for appropriate dosing for your animal model.[15][16]

- Dietary Modification: Provide a highly palatable and easily digestible diet.

### **Problem 3: Elevated liver enzymes (ALT) are observed in serum chemistry.**

- Potential Cause: Almonertinib can induce hepatotoxicity, as indicated by elevated ALT levels in clinical trials.[4][5]
- Troubleshooting Steps:
  - Confirm the Finding: Repeat the blood work to confirm the elevation of liver enzymes.
  - Dose Modification: A dose reduction or temporary discontinuation of Almonertinib may be necessary.
  - Histopathology: At necropsy, collect liver tissue for histopathological evaluation to assess the extent of any liver damage.
  - Rule out Other Causes: Ensure that other experimental factors or co-administered agents are not contributing to the liver toxicity.

## **Quantitative Data Summary**

The following table summarizes dose-escalation and adverse event data from a Phase 1 clinical trial of Almonertinib in humans. This data can provide a reference for potential dose-dependent toxicities in animal models, but it is crucial to perform dedicated dose-range finding studies in the specific animal model being used.

Dose Level (Human)	Most Common Grade $\geq$ 3 Treatment-Related Adverse Events
55 mg	Data not specifically stratified by dose in the provided results.
110 mg	Increased blood creatine phosphokinase (10%), Increased alanine aminotransferase (3%)[4][5]
220 mg	Data not specifically stratified by dose in the provided results.
260 mg	Not further evaluated due to safety concerns and saturation of exposure.[4][5]

## Experimental Protocols

### Protocol 1: Assessment and Management of Almonertinib-Induced Dermatitis in Mice

- Animal Model: Utilize an appropriate tumor-bearing mouse model for your study.
- Dosing: Administer Almonertinib at the desired dose and schedule, based on prior dose-range finding studies.
- Monitoring:
  - Visually inspect the skin of each animal daily.
  - Score the severity of the skin rash using a standardized scale (e.g., 0 = no rash, 1 = mild erythema, 2 = moderate erythema with papules, 3 = severe erythema with pustules and/or ulceration).
  - Record the body weight and general health status daily.
- Management:
  - For Grade 1 rash, continue monitoring.

- For Grade 2 rash, consider applying a topical emollient daily.
- For Grade 3 rash, interrupt Almonertinib dosing until the rash improves to Grade 1 or less. Consider a dose reduction upon re-initiation of treatment.
- Pathology: At the end of the study, collect skin samples for histopathological analysis to evaluate epidermal changes and inflammatory infiltrates.

## Protocol 2: Monitoring and Management of Almonertinib-Induced Diarrhea in Mice

- Animal Model: Use a suitable tumor-bearing mouse model.
- Dosing: Administer Almonertinib as planned.
- Monitoring:
  - Measure the body weight of each animal daily.
  - Assess fecal consistency daily using a scoring system (e.g., 0 = normal, well-formed pellets; 1 = soft pellets; 2 = loose, unformed stool; 3 = watery diarrhea).
  - Monitor for signs of dehydration (e.g., skin tenting, reduced activity).
- Management:
  - For Grade 1-2 diarrhea, ensure adequate hydration with free access to water and consider providing electrolyte-supplemented water.
  - For Grade 3 diarrhea or significant weight loss (>15%), suspend Almonertinib treatment. Administer subcutaneous fluids (e.g., 1 mL of sterile saline). Consider initiating loperamide treatment after veterinary consultation.
- Intestinal Histopathology: At necropsy, collect sections of the small and large intestines to evaluate for mucosal changes.

## Visualizations

## Simplified EGFR Signaling Pathway and Almonertinib Inhibition

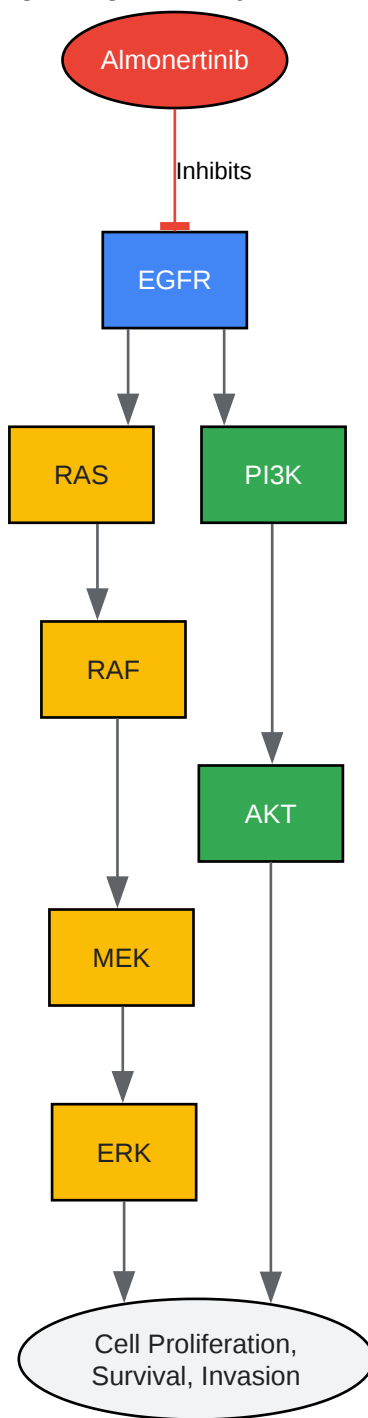

[Click to download full resolution via product page](#)

Caption: Almonertinib inhibits the EGFR signaling pathway.

Experimental Workflow for Managing Almonertinib Toxicity

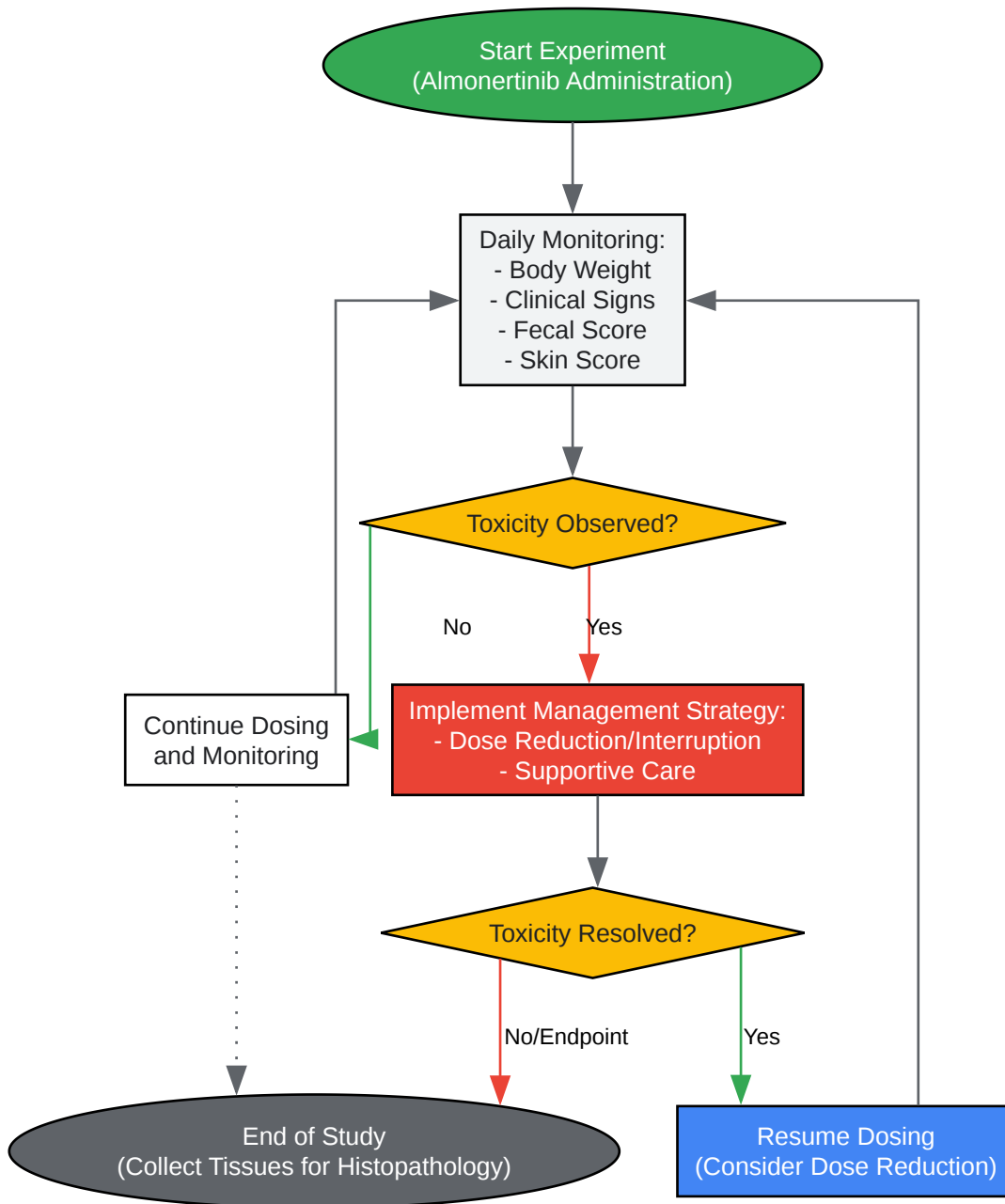

[Click to download full resolution via product page](#)

Caption: Workflow for toxicity management in animal studies.

## Mechanism of Almonertinib-Induced Skin Toxicity

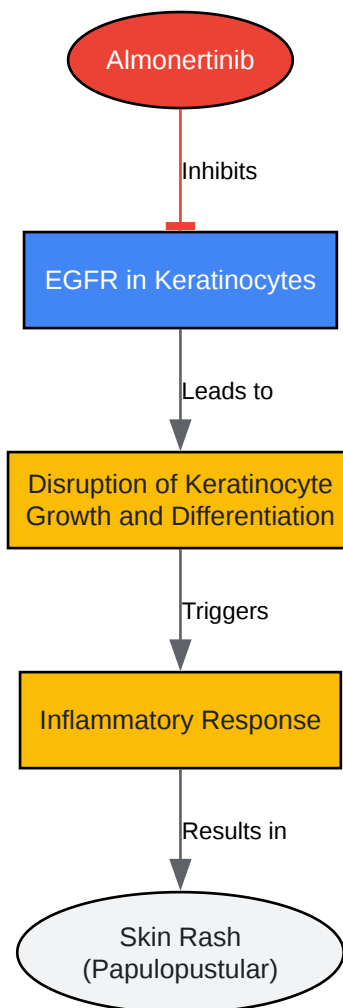

[Click to download full resolution via product page](#)

Caption: Pathophysiology of Almonertinib-induced skin rash.

### Need Custom Synthesis?

BenchChem offers custom synthesis for rare earth carbides and specific isotopic labeling.

Email: [info@benchchem.com](mailto:info@benchchem.com) or [Request Quote Online](#).

## References

- 1. [medkoo.com](https://www.medkoo.com) [medkoo.com]
- 2. What is the mechanism of Almonertinib Mesilate? [synapse.patsnap.com]

- [3. The efficacy of almonertinib and anlotinib combination therapy for advanced non-small-cell lung cancer patients who continued to experience cancer progression during third-generation EGFR-TKI treatment: a retrospective study - PMC \[pmc.ncbi.nlm.nih.gov\]](#)
- [4. researchgate.net \[researchgate.net\]](#)
- [5. Safety, Efficacy, and Pharmacokinetics of Almonertinib \(HS-10296\) in Pretreated Patients With EGFR-Mutated Advanced NSCLC: A Multicenter, Open-label, Phase 1 Trial - PubMed \[pubmed.ncbi.nlm.nih.gov\]](#)
- [6. benchchem.com \[benchchem.com\]](#)
- [7. benchchem.com \[benchchem.com\]](#)
- [8. Dose Range Finding in Preclinical Studies | Altasciences Blog \[altasciences.com\]](#)
- [9. nc3rs.org.uk \[nc3rs.org.uk\]](#)
- [10. Mechanism of Lethal Skin Toxicities Induced by Epidermal Growth Factor Receptor Inhibitors and Related Treatment Strategies - PMC \[pmc.ncbi.nlm.nih.gov\]](#)
- [11. Reducing Skin Toxicities from EGFR Inhibitors with Topical BRAF Inhibitor Therapy - PMC \[pmc.ncbi.nlm.nih.gov\]](#)
- [12. Management of diarrhea induced by EGFR-TKIs in advanced lung adenocarcinoma - PMC \[pmc.ncbi.nlm.nih.gov\]](#)
- [13. researchgate.net \[researchgate.net\]](#)
- [14. benchchem.com \[benchchem.com\]](#)
- [15. Mechanism and treatment of diarrhea associated with tyrosine kinase inhibitors - PMC \[pmc.ncbi.nlm.nih.gov\]](#)
- [16. Diarrhea Induced by Small Molecule Tyrosine Kinase Inhibitors Compared With Chemotherapy: Potential Role of the Microbiome - PMC \[pmc.ncbi.nlm.nih.gov\]](#)
- To cite this document: BenchChem. [Technical Support Center: Managing Almonertinib Toxicity in Animal Models]. BenchChem, [2026]. [Online PDF]. Available at: [\[https://www.benchchem.com/product/b2543745/docs#technical-support-center-managing-almonertinib-toxicity-in-animal-models\]](https://www.benchchem.com/product/b2543745/docs#technical-support-center-managing-almonertinib-toxicity-in-animal-models)

---

### Disclaimer & Data Validity:

The information provided in this document is for Research Use Only (RUO) and is strictly not intended for diagnostic or therapeutic procedures. While BenchChem strives to provide

accurate protocols, we make no warranties, express or implied, regarding the fitness of this product for every specific experimental setup.

**Technical Support:** The protocols provided are for reference purposes. Unsure if this reagent suits your experiment?

**Need Industrial/Bulk Grade?** [Request Custom Synthesis Quote](#)

## BenchChem

Our mission is to be the trusted global source of essential and advanced chemicals, empowering scientists and researchers to drive progress in science and industry.

### Contact

Address: 3281 E Guasti Rd

Ontario, CA 91761, United States

Phone: (601) 213-4426

Email: [info@benchchem.com](mailto:info@benchchem.com)

[Contact our Ph.D. Support Team for a compatibility check](#)