

Technical Guide: Cross-Resistance Patterns Between Propanil and Methoxyimino Derivatives

Author: BenchChem Technical Support Team. **Date:** April 2026

Compound of Interest

Compound Name: *N*-(3,4-dichlorophenyl)-3-(methoxyimino)propanamide
CAS No.: 477851-71-1
Cat. No.: B2543674

[Get Quote](#)

Executive Summary

This guide analyzes the resistance dynamics between Propanil (an amide herbicide) and Methoxyimino derivatives (specifically focusing on ALS-inhibiting herbicides like Pyriminobac-methyl and Bispyribac-sodium, and related oxime chemistries).

Core Insight: Contrary to direct cross-resistance, these two classes typically exhibit distinct metabolic routes and target sites. Propanil resistance is predominantly driven by Aryl Acylamidase (AAA), whereas resistance to methoxyimino derivatives is driven by Acetolactate Synthase (ALS) point mutations or Cytochrome P450 metabolism. Consequently, true cross-resistance (one mechanism conferring resistance to both) is rare. Instead, researchers often observe Multiple Resistance (accumulation of independent mechanisms) or Synergism (where one inhibits the detoxification of the other).

Part 1: Chemical & Mechanistic Profiling

The Challengers

To understand resistance, we must first isolate the mechanism of action (MoA) and primary detoxification pathways.

Feature	Propanil	Methoxyimino Derivatives (e.g., Pyriminobac, Bispyribac)
Chemical Class	Anilide / Amide	Pyrimidinyl carboxy / Benzoate (containing methoxyimino group)
Target Site	Photosystem II (PSII) (D1 protein, psbA gene)	Acetolactate Synthase (ALS) (ALS gene)
Primary Resistance Driver	Metabolic: Hydrolysis by Aryl Acylamidase (AAA)	Target Site: Point mutations (e.g., Trp574Leu) Metabolic: Hydroxylation by Cytochrome P450s
Key Metabolite	3,4-dichloroaniline (DCA)	Hydroxylated/Demethylated conjugates
Synergist Marker	Inhibited by Carbamates/Organophosphate s (e.g., Carbaryl)	Inhibited by P450 inhibitors (e.g., Malathion, PBO)

The "Methoxyimino" Structural Context

In agrochemistry, the "methoxyimino" group (

) is a pharmacophore often found in:

- ALS Inhibitors: Pyriminobac-methyl, Bispyribac-sodium (structural analogs).
- Strobilurin Fungicides: Kresoxim-methyl (relevant for cross-resistance via broad-spectrum efflux pumps or P450s, though less common in herbicide contexts).

Part 2: Cross-Resistance vs. Multiple Resistance The Divergent Metabolic Pathways

The most critical distinction for drug development professionals is that AAA (Propanil-specific) does not typically degrade methoxyimino structures. Conversely, P450s that degrade ALS inhibitors rarely metabolize Propanil efficiently enough to confer high-level resistance.

Diagram 1: Divergent Detoxification Pathways

This diagram illustrates why true cross-resistance is rare: the enzymatic "keys" are different.

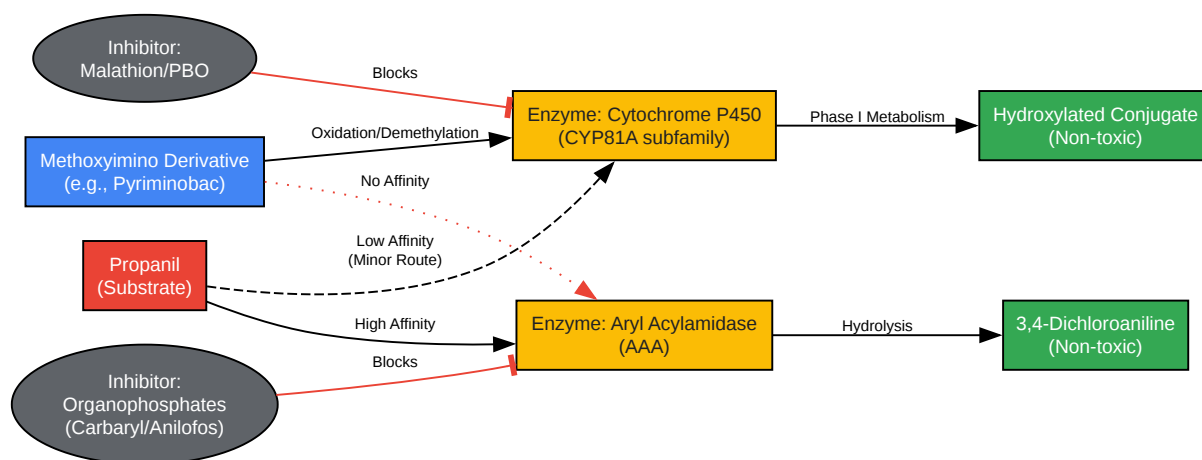

[Click to download full resolution via product page](#)

Caption: Metabolic segregation between Propanil (AAA-mediated) and Methoxyimino derivatives (P450-mediated).

Synergistic Potential (The "Negative" Cross-Resistance)

Because the resistance mechanisms are distinct, these compounds often act as synergists rather than exhibiting cross-resistance.

- Mechanism: Propanil acts as a competitive substrate or inhibitor for certain amidases/esterases that might otherwise degrade co-applied herbicides.
- Field Data: Populations of *Echinochloa crus-galli* resistant to Bispyribac-sodium (via ALS mutation) often remain fully susceptible to Propanil, unless they have independently evolved AAA overexpression (Multiple Resistance).

Part 3: Experimental Protocols for Characterization

To validate whether a population exhibits Cross-Resistance (single mechanism) or Multiple Resistance (independent mechanisms), use this self-validating workflow.

Protocol A: The Synergist Diagnostic Assay

Objective: Differentiate between AAA-mediated and P450-mediated resistance.

Materials:

- Synergist 1: Carbaryl (Specific AAA inhibitor).
- Synergist 2: Malathion or Piperonyl Butoxide (PBO) (General P450 inhibitors).
- Target: 3-4 leaf stage Echinochloa seedlings.

Step-by-Step Methodology:

- Baseline Establishment: Determine

(Growth Reduction 50%) for Propanil and the Methoxyimino candidate separately.

- Pre-Treatment: Apply Synergist 1 (Carbaryl @ 1000 g a.i./ha) or Synergist 2 (Malathion @ 1000 g a.i./ha) 24 hours prior to herbicide application. Note: Ensure synergist controls show no phytotoxicity alone.
- Treatment: Apply herbicide at

and

field rates.
- Evaluation (7 Days After Treatment):
 - Result A: If Carbaryl restores Propanil sensitivity but not Methoxyimino sensitivity

Independent Mechanisms (AAA vs. Target Site/P450).
 - Result B: If Malathion restores sensitivity to both

Metabolic Cross-Resistance (Rare P450 dominance).

- Result C: If neither synergist works

Target Site Resistance (likely psbA and ALS mutations).

Protocol B: Enzyme Activity Quantification (AAA Assay)

Objective: Confirm if Propanil resistance is metabolic (AAA-driven).

- Extraction: Homogenize 1g leaf tissue in 0.1 M Tris-HCl (pH 7.5) with 1 mM DTT. Centrifuge at 10,000g for 20 min.
- Incubation: Mix supernatant with 1 mM Propanil substrate. Incubate at 30°C for 30-60 mins.
- Termination: Stop reaction with 10% TCA.
- Detection: Measure 3,4-dichloroaniline (DCA) production via diazotization (colorimetric assay at 550 nm) or HPLC (C18 column, Acetonitrile:Water 60:40).
- Validation: High DCA levels in resistant biotypes vs. near-zero in susceptible ones confirms AAA activity.

Part 4: Data Visualization & Diagnostic Logic

Diagram 2: Diagnostic Decision Tree

Use this logic flow to categorize the resistance pattern in your target population.

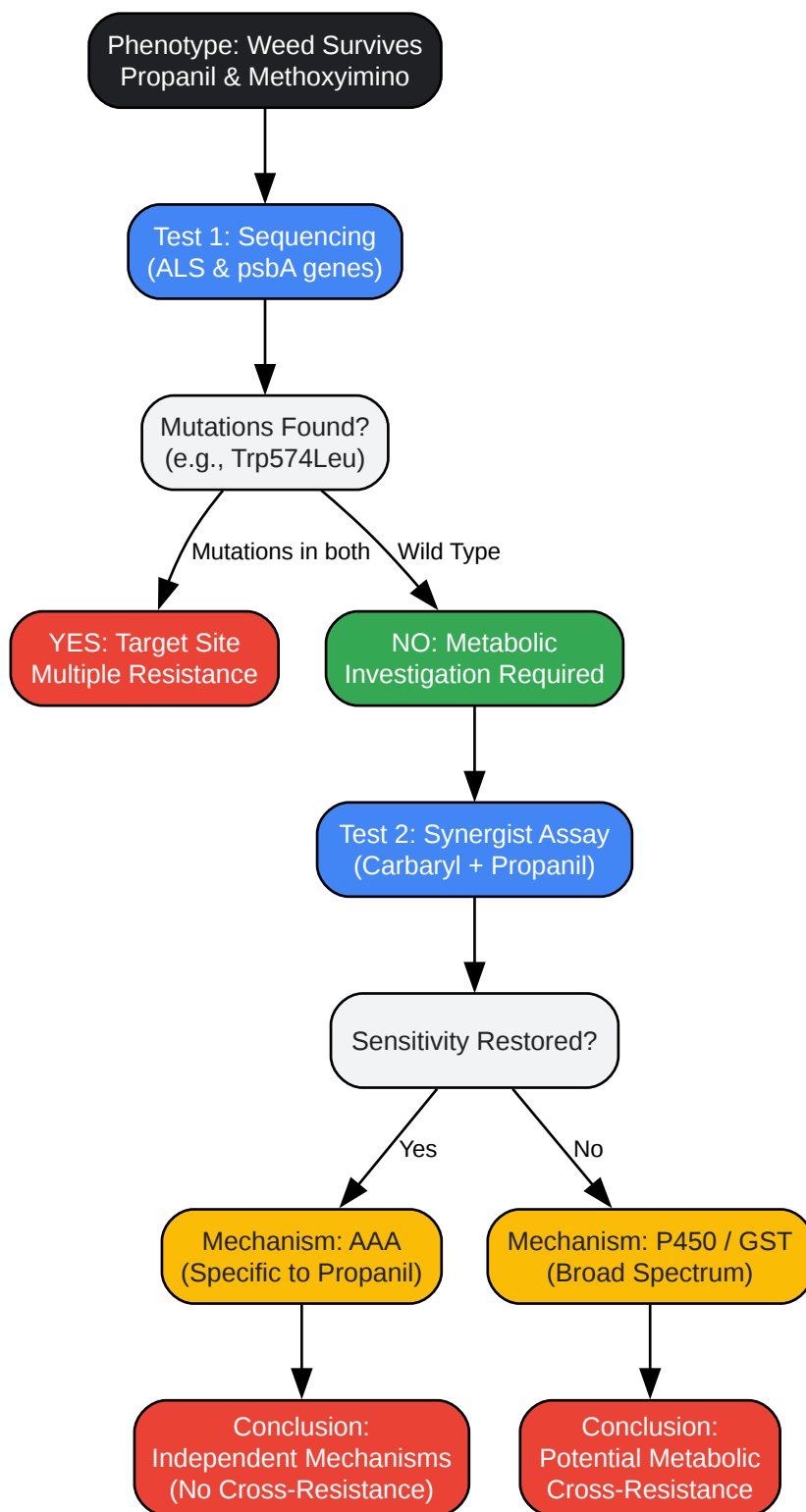

[Click to download full resolution via product page](#)

Caption: Workflow to distinguish between Target-Site Multiple Resistance and Metabolic Cross-Resistance.

References

- Leah, J. M., et al. (1994). Association between elevated activity of aryl acylamidase and propanil resistance in Jungle-rice, *Echinochloa colona*. *Pesticide Science*. [Link](#)
- Carey, V. F., et al. (1997).[1] Resistance mechanism of propanil-resistant barnyardgrass: II. In-vivo metabolism of the propanil molecule. *Pesticide Science*. [Link](#)
- Iwakami, S., et al. (2014).[2] Cytochrome P450 genes induced by bispyribac-sodium treatment in a multiple-herbicide-resistant biotype of *Echinochloa phyllopogon*. *Pest Management Science*. [Link](#)
- Riar, D. S., et al. (2013). Acetolactate synthase functions in herbicide-resistant barnyardgrass (*Echinochloa crus-galli*) biotypes. *Weed Science*. [Link](#)
- Hoagland, R. E., et al. (2004). Propanil metabolism by rhizosphere microbes and propanil-resistant weeds. *Weed Technology*. [Link](#)

Need Custom Synthesis?

BenchChem offers custom synthesis for rare earth carbides and specific isotopic labeling.

Email: info@benchchem.com or [Request Quote Online](#).

Sources

- [1. Metabolism-Based Herbicide Resistance and Cross-Resistance in Crop Weeds: A Threat to Herbicide Sustainability and Global Crop Production - PMC \[pmc.ncbi.nlm.nih.gov\]](#)
- [2. peerj.com \[peerj.com\]](#)
- To cite this document: BenchChem. [Technical Guide: Cross-Resistance Patterns Between Propanil and Methoxyimino Derivatives]. BenchChem, [2026]. [Online PDF]. Available at: [<https://www.benchchem.com/product/b2543674/docs#technical-guide-cross-resistance-patterns-between-propanil-and-methoxyimino-derivatives>]

Disclaimer & Data Validity:

The information provided in this document is for Research Use Only (RUO) and is strictly not intended for diagnostic or therapeutic procedures. While BenchChem strives to provide accurate protocols, we make no warranties, express or implied, regarding the fitness of this product for every specific experimental setup.

Technical Support: The protocols provided are for reference purposes. Unsure if this reagent suits your experiment?

Need Industrial/Bulk Grade? [Request Custom Synthesis Quote](#)

BenchChem

Our mission is to be the trusted global source of essential and advanced chemicals, empowering scientists and researchers to drive progress in science and industry.

Contact

Address: 3281 E Guasti Rd
Ontario, CA 91761, United States
Phone: (601) 213-4426
Email: info@benchchem.com

[Contact our Ph.D. Support Team for a compatibility check](#)