

Optimizing TBAP-001 concentration for cell culture experiments

Author: BenchChem Technical Support Team. **Date:** April 2026

Compound of Interest

Compound Name: TBAP-001
CAS No.: 1777832-90-2
Cat. No.: B2541119

[Get Quote](#)

Technical Support Center: TBAP-001

Welcome to the technical support center for **TBAP-001**, a novel and potent allosteric inhibitor of the mTORC1 complex. This guide provides troubleshooting advice and frequently asked questions to help you optimize your cell culture experiments.

Frequently Asked Questions (FAQs)

Q1: What is the recommended starting concentration for **TBAP-001** in my cell line?

A1: For a novel compound like **TBAP-001**, it is advisable to start with a broad range of concentrations to establish a dose-response curve.^[1] A logarithmic or semi-logarithmic dilution series is recommended, for instance, from 1 nM to 10 μ M.^{[1][2]} For most sensitive cancer cell lines with a hyperactivated PI3K/AKT/mTOR pathway (e.g., MCF-7, A549, U-87 MG), the optimal concentration range is typically between 10-100 nM.

Q2: How do I determine the optimal concentration of **TBAP-001** for my specific cell line?

A2: The optimal concentration is cell-line dependent. To determine this, you should perform a cell viability assay (e.g., MTT, MTS, or Trypan Blue exclusion) with a range of **TBAP-001** concentrations.[1] The goal is to identify the IC50 value, which is the concentration that inhibits 50% of cell growth or viability.[3] It is recommended to perform these assays at different time points (e.g., 24, 48, and 72 hours) to understand the time-dependent effects of the compound.
[1]

Q3: My cells are showing signs of stress or dying even at low concentrations of **TBAP-001**. What should I do?

A3: High cytotoxicity at low concentrations could be due to several factors:

- High Sensitivity of the Cell Line: Your cell line might be exceptionally sensitive to mTORC1 inhibition.
- Solvent Toxicity: Ensure the final concentration of the solvent (e.g., DMSO) is not exceeding 0.1-0.5% in your culture medium.
- Incorrect Concentration: Double-check your stock solution and dilution calculations.

If the issue persists, consider using a narrower and lower concentration range for your dose-response experiments.

Q4: I am not observing any effect of **TBAP-001** on my cells. What could be the reason?

A4: A lack of response could be due to:

- Cell Line Resistance: The cell line you are using may not have a dysregulated mTOR pathway, or it may have compensatory signaling pathways.[4]
- Compound Inactivity: Verify the integrity and proper storage of your **TBAP-001** stock.
- Insufficient Incubation Time: The effect of **TBAP-001** may be time-dependent. Consider extending the incubation period.[5]
- Suboptimal Cell Culture Conditions: Ensure your cells are healthy and in the logarithmic growth phase before adding the compound.[6]

Q5: How can I confirm that **TBAP-001** is inhibiting the mTOR pathway in my cells?

A5: You can perform a Western blot analysis to assess the phosphorylation status of downstream targets of mTORC1.[7] A decrease in the phosphorylation of S6 kinase (S6K) at Thr389 and 4E-BP1 at Thr37/46 would confirm the on-target activity of **TBAP-001**. [7][8]

Data Presentation

Table 1: IC50 Values of **TBAP-001** in Various Cancer Cell Lines

Cell Line	Cancer Type	IC50 (nM)
MCF-7	Breast Cancer	15
A549	Lung Cancer	25
U-87 MG	Glioblastoma	50
PC-3	Prostate Cancer	120
HCT116	Colon Cancer	85

Table 2: Troubleshooting Guide for **TBAP-001** Experiments

Observed Problem	Potential Cause(s)	Recommended Solution(s)
High Cell Death at All Concentrations	Solvent toxicity, calculation error, high cell line sensitivity.	Prepare a fresh stock of TBAP-001, verify calculations, and use a lower concentration range.
No Effect at Any Concentration	Cell line resistance, inactive compound, insufficient incubation time.	Use a positive control cell line, check compound integrity, and perform a time-course experiment.
High Variability Between Replicates	Pipetting errors, uneven cell seeding, edge effects.	Use calibrated pipettes, ensure a single-cell suspension, and avoid using the outer wells of the plate. ^[1]
Bell-Shaped Dose-Response Curve	Off-target effects at high concentrations, compound precipitation.	Investigate potential off-target effects and test a narrower concentration range. ^[1]

Experimental Protocols

Protocol 1: Determining Optimal Concentration using MTT Assay

Objective: To determine the IC₅₀ of **TBAP-001** in a specific cell line.

Materials:

- 96-well cell culture plates
- **TBAP-001** stock solution (e.g., 10 mM in DMSO)
- Complete culture medium
- MTT reagent (5 mg/mL in PBS)
- DMSO

Procedure:

- Seed cells in a 96-well plate at a predetermined optimal density and incubate for 24 hours.[6]
- Prepare serial dilutions of **TBAP-001** in complete culture medium. A common approach is a 1:10 dilution series (e.g., 10 μ M, 1 μ M, 100 nM, 10 nM, 1 nM).[1]
- Remove the old medium and add 100 μ L of the medium containing different concentrations of **TBAP-001** to the respective wells. Include vehicle-only (DMSO) and untreated controls.
- Incubate the plate for the desired time period (e.g., 48 hours).
- Add 20 μ L of MTT reagent to each well and incubate for 4 hours at 37°C.
- Remove the medium and add 150 μ L of DMSO to each well to dissolve the formazan crystals.
- Measure the absorbance at 570 nm using a microplate reader.
- Plot the percentage of cell viability against the log of **TBAP-001** concentration to generate a dose-response curve and calculate the IC50 value.[1]

Protocol 2: Western Blot for mTORC1 Pathway Inhibition

Objective: To confirm the inhibitory effect of **TBAP-001** on the mTORC1 signaling pathway.

Materials:

- 6-well cell culture plates
- **TBAP-001**
- Lysis buffer (e.g., RIPA buffer) with protease and phosphatase inhibitors
- Primary antibodies (anti-phospho-S6K, anti-S6K, anti-phospho-4E-BP1, anti-4E-BP1, anti-actin)
- HRP-conjugated secondary antibodies

- ECL substrate

Procedure:

- Seed cells in 6-well plates and grow until they reach 70-80% confluency.
- Treat the cells with **TBAP-001** at the predetermined IC50 concentration for the desired time.
- Wash the cells with ice-cold PBS and lyse them with lysis buffer.
- Determine the protein concentration of the lysates using a BCA or Bradford assay.
- Separate the proteins by SDS-PAGE and transfer them to a PVDF membrane.
- Block the membrane with 5% non-fat milk or BSA in TBST for 1 hour.
- Incubate the membrane with primary antibodies overnight at 4°C.
- Wash the membrane with TBST and incubate with HRP-conjugated secondary antibodies for 1 hour at room temperature.
- Wash the membrane again and visualize the protein bands using an ECL substrate and an imaging system.

Visualizations

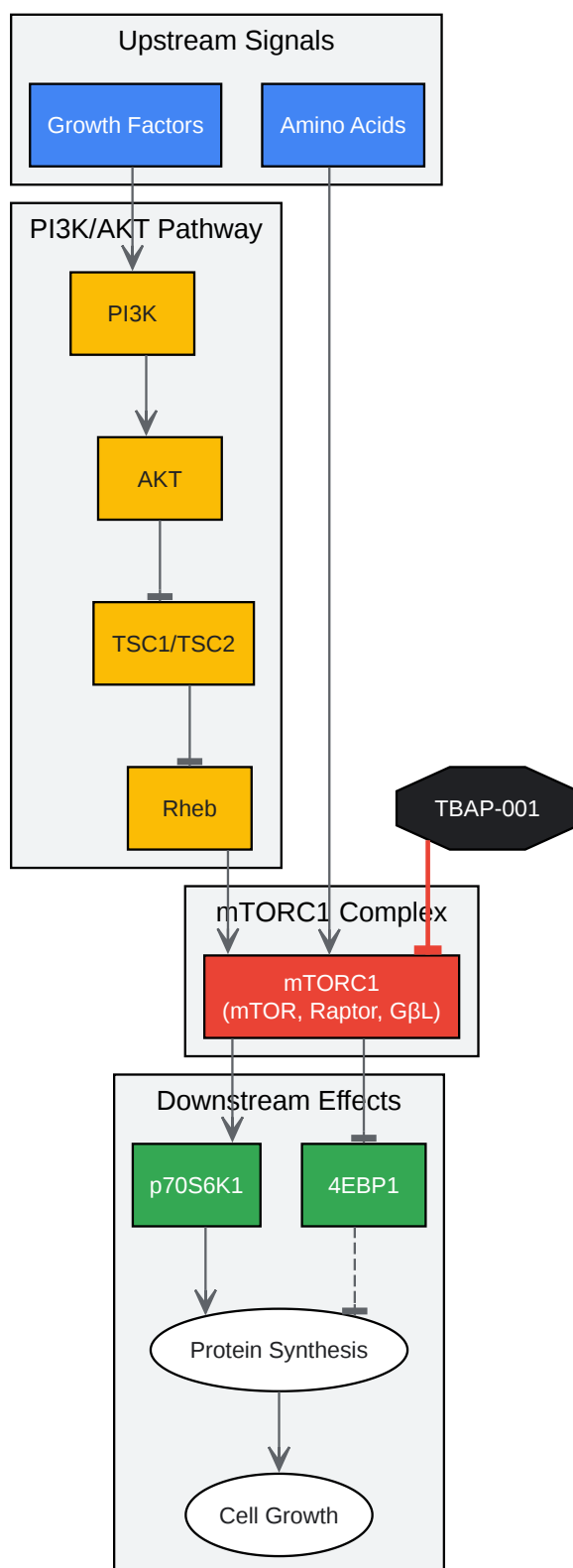

[Click to download full resolution via product page](#)

Caption: The mTOR signaling pathway and the inhibitory action of **TBAP-001**.

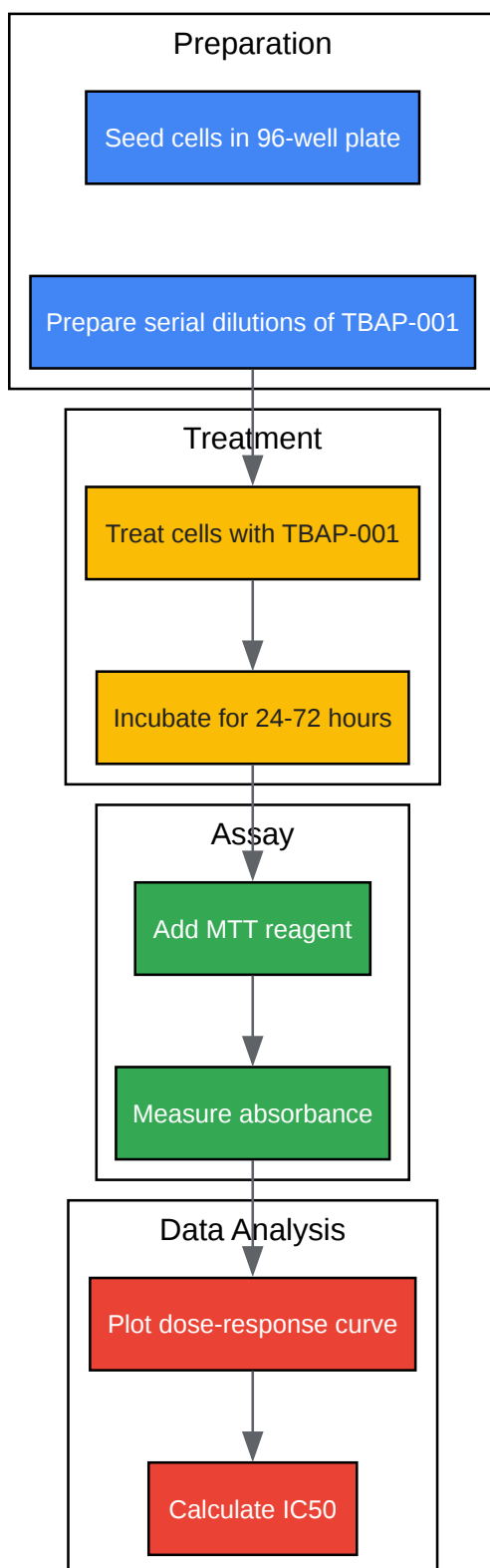

[Click to download full resolution via product page](#)

Caption: Workflow for determining the optimal concentration of **TBAP-001**.

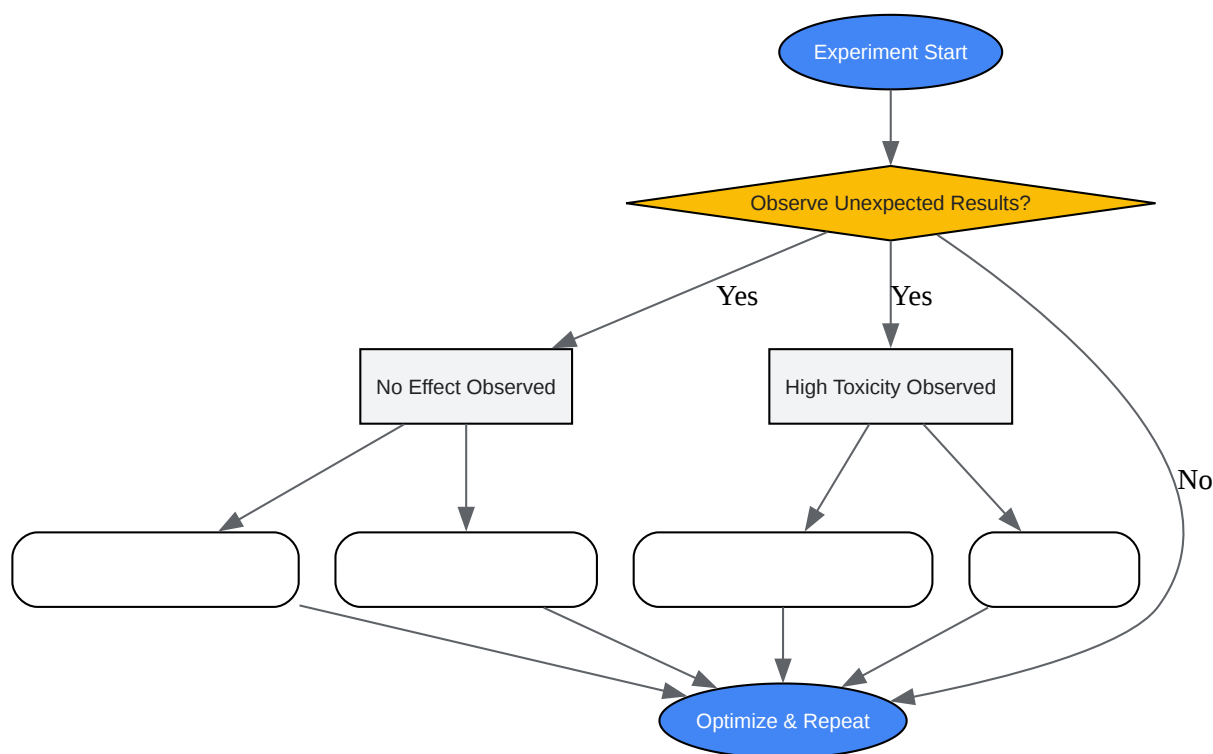

[Click to download full resolution via product page](#)

Caption: A logical diagram for troubleshooting common experimental issues.

Need Custom Synthesis?

BenchChem offers custom synthesis for rare earth carbides and specific isotopic labeling.

Email: info@benchchem.com or [Request Quote Online](#).

References

- [1. benchchem.com \[benchchem.com\]](https://www.benchchem.com)
- [2. researchgate.net \[researchgate.net\]](https://www.researchgate.net)
- [3. researchgate.net \[researchgate.net\]](https://www.researchgate.net)

- [4. aacrjournals.org \[aacrjournals.org\]](https://aacrjournals.org)
- [5. bitesizebio.com \[bitesizebio.com\]](https://bitesizebio.com)
- [6. sorger.med.harvard.edu \[sorger.med.harvard.edu\]](https://sorger.med.harvard.edu)
- [7. researchgate.net \[researchgate.net\]](https://researchgate.net)
- [8. Updates of mTOR inhibitors - PMC \[pmc.ncbi.nlm.nih.gov\]](https://pubmed.ncbi.nlm.nih.gov)
- To cite this document: BenchChem. [Optimizing TBAP-001 concentration for cell culture experiments]. BenchChem, [2026]. [Online PDF]. Available at: [\[https://www.benchchem.com/product/b2541119/docs#optimizing-tbap-001-concentration-for-cell-culture-experiments\]](https://www.benchchem.com/product/b2541119/docs#optimizing-tbap-001-concentration-for-cell-culture-experiments)

Disclaimer & Data Validity:

The information provided in this document is for Research Use Only (RUO) and is strictly not intended for diagnostic or therapeutic procedures. While BenchChem strives to provide accurate protocols, we make no warranties, express or implied, regarding the fitness of this product for every specific experimental setup.

Technical Support: The protocols provided are for reference purposes. Unsure if this reagent suits your experiment?

Need Industrial/Bulk Grade? [Request Custom Synthesis Quote](#)

BenchChem

Our mission is to be the trusted global source of essential and advanced chemicals, empowering scientists and researchers to drive progress in science and industry.

Contact

Address: 3281 E Guasti Rd

Ontario, CA 91761, United States

Phone: (601) 213-4426

Email: info@benchchem.com

Contact our Ph.D. Support Team for a compatibility check