

Technical Support Center: Optimizing Solvent Choice for Unsymmetrical Diamine Cyclization

Author: BenchChem Technical Support Team. **Date:** May 2026

Compound of Interest

Compound Name: *3-Bromo-6-chlorobenzene-1,2-diamine*

CAS No.: 1823876-88-5

Cat. No.: B2540400

[Get Quote](#)

Welcome to the technical support center dedicated to the nuanced challenge of solvent optimization for the cyclization of unsymmetrical diamines. This guide is designed for researchers, medicinal chemists, and process development professionals who are navigating the complexities of forming heterocyclic structures from precursors with non-equivalent reactive centers. The choice of solvent is not merely about dissolution; it is a critical parameter that dictates regioselectivity, reaction rate, and the suppression of side products.^{[1][2]}

This resource moves beyond generic advice to provide in-depth, mechanistically-grounded troubleshooting strategies and answers to frequently encountered experimental hurdles.

Core Principles: The Role of the Solvent

Far from being a passive medium, the solvent actively shapes the reaction's energy landscape.

^[1] Its influence is primarily exerted through:

- **Differential Solvation:** The solvent's ability to stabilize the reactants, intermediates, transition states, and products to different extents.^{[3][4]} A solvent that preferentially stabilizes the

transition state leading to the desired product will accelerate the reaction.[3]

- **Reactant Organization:** The solvent shell around the unsymmetrical diamine can influence its conformation, pre-organizing it for cyclization and potentially favoring the formation of one regioisomer over another.
- **Participation in the Reaction:** Protic solvents can act as proton donors or acceptors, directly participating in the reaction mechanism, for instance, by activating an electrophile or stabilizing a charged intermediate through hydrogen bonding.[4][5][6]

Troubleshooting Guide & FAQs

This section addresses common issues encountered during the cyclization of unsymmetrical diamines in a practical question-and-answer format.

Issue 1: Poor or No Regioselectivity

Q: My reaction is producing a mixture of regioisomers. How can I improve the selectivity for the desired product?

A: Poor regioselectivity is the most common challenge and is directly influenced by the solvent's ability to differentiate between the two non-equivalent amino groups and stabilize the respective transition states.

- **Underlying Cause:** The two amine groups of the unsymmetrical diamine possess different steric and electronic environments. The solvent's polarity, proticity, and hydrogen-bonding capability can either amplify or diminish these intrinsic differences. For instance, a polar protic solvent might preferentially solvate the less sterically hindered amine, making the more hindered one more available for reaction, or vice-versa depending on the specific substrate and reaction mechanism.
- **Troubleshooting Strategies:**
 - **Vary Solvent Polarity:** The polarity of the solvent can significantly influence which reaction pathway is favored.[3]
 - **Polar Aprotic Solvents (e.g., DMF, DMSO, Acetonitrile):** These solvents are excellent at dissolving charged species and can stabilize polar transition states.[5] They are a good

starting point if the cyclization involves the formation of a charged intermediate.

- Non-Polar Aprotic Solvents (e.g., Toluene, Dichloromethane, Dioxane): These solvents are less likely to strongly interact with the reactants and may allow the intrinsic reactivity of the diamine to dominate.^[7] In some cases, this can lead to higher selectivity. They are generally preferred for reactions involving carbene insertions to minimize side reactions with the solvent.^[7]
- Polar Protic Solvents (e.g., Ethanol, Methanol, Water): The ability of these solvents to hydrogen bond can be a double-edged sword.^[5] They can stabilize charged intermediates but may also deactivate a nucleophilic amine through hydrogen bonding, slowing the reaction or altering selectivity.^{[6][8]} However, in some cases, they can facilitate proton transfer steps that are crucial for the desired cyclization pathway.^[9]
- Consider "Green" Solvents: Water, ionic liquids, and deep eutectic solvents can offer unique reactivity profiles and should be considered during screening.^{[10][11][12]}
- High Dilution: Intermolecular side reactions can compete with the desired intramolecular cyclization. Performing the reaction under high dilution conditions, by slowly adding the substrate to a large volume of solvent, can favor the intramolecular pathway.^[7]

Issue 2: Low or No Yield of Cyclized Product

Q: I'm observing very little or no formation of my desired heterocyclic product. What are the likely causes and solutions?

A: Low yields can stem from several factors, including slow reaction kinetics, decomposition of starting materials or products, and competing side reactions.

- Underlying Cause & Troubleshooting Strategies:
 - Poor Solubility: Ensure your starting materials are fully dissolved in the chosen solvent at the reaction temperature. If solubility is an issue, a different solvent or a co-solvent system may be necessary. Computational tools like COSMO-RS can aid in predicting solubility and guiding solvent selection.^{[13][14][15]}

- Decomposition: The starting diamine or the cyclized product may be unstable under the reaction conditions.
 - Action: Run the reaction at a lower temperature. While this may decrease the reaction rate, it can improve the overall yield by minimizing degradation.[7] Also, ensure the reaction is performed under an inert atmosphere (e.g., nitrogen or argon) if your compounds are sensitive to air or moisture.[7]
- Unfavorable Kinetics: The activation energy for the cyclization may be too high in the chosen solvent.
 - Action: Switch to a solvent that can better stabilize the transition state.[3] For reactions that proceed through a more polar transition state than the ground state, increasing the solvent polarity will increase the reaction rate.[3] Conversely, if the transition state is less polar than the reactants, a less polar solvent may be beneficial.[16]
- Intermolecular Polymerization: As mentioned, intermolecular reactions can be a significant competing pathway.
 - Action: Employ high dilution techniques.[7]

Issue 3: Formation of Unexpected Side Products

Q: My reaction is clean by TLC, but after workup and purification, I isolate a product that is not my target heterocycle. What could be happening?

A: The solvent can sometimes participate in the reaction or promote alternative reaction pathways, leading to unexpected products.

- Underlying Cause & Troubleshooting Strategies:
 - Solvent Participation: Protic solvents can sometimes act as nucleophiles, or aprotic solvents can be susceptible to deprotonation under basic conditions, leading to their incorporation into the product.
 - Action: Switch to a more inert solvent. If a protic solvent is necessary for the reaction mechanism, consider one that is less nucleophilic (e.g., tert-butanol vs. methanol).

- Promotion of Alternative Pathways: A particular solvent might favor a competing reaction, such as an elimination or rearrangement, over the desired cyclization.
 - Action: A systematic solvent screen is the best approach here. Changing the solvent's properties (polarity, proticity) can dramatically alter the product distribution.

Data-Driven Solvent Selection

A systematic approach to solvent screening is crucial for efficient optimization. The following table provides key properties of common solvents to guide your selection process.

Solvent	Dielectric Constant (ϵ) at 25°C[3]	Type	Key Characteristics & Typical Applications
Water	78	Polar Protic	Highly polar, excellent at stabilizing ions. Can promote reactions through hydrogen bonding. A "green" solvent option.[3][10]
Dimethyl Sulfoxide (DMSO)	47	Polar Aprotic	High dielectric constant, dissolves a wide range of compounds. Can accelerate SN2 reactions.[3]
Acetonitrile	37	Polar Aprotic	Less viscous than DMSO, easier to remove. Good for reactions involving charged intermediates.[3]
Methanol	32.7	Polar Protic	Can act as a proton source and hydrogen-bond donor. Often used when a mild acid catalyst is implicitly needed.[16]
Ethanol	24.55	Polar Protic	Similar to methanol but less polar and toxic. A good "green" alternative.[16]
Dichloromethane (DCM)	9.1	Aprotic (borderline polar)	Good general-purpose solvent for a wide range of organic

compounds.
Relatively non-coordinating.

Ethereal solvent, can coordinate to metal cations.

Can facilitate reactions at higher temperatures. Good for reactions where polarity needs to be minimized.

A higher boiling point ethereal solvent, miscible with water.

Very non-polar, used when trying to minimize all solvent interactions.

Experimental Protocols

Protocol 1: Systematic Solvent Screening for Cyclization Optimization

This protocol outlines a parallel screening approach to efficiently identify a suitable solvent.

- **Preparation:** In an array of reaction vials, place an equal amount of the unsymmetrical diamine and any other necessary reagents (e.g., the electrophile for cyclocondensation).
- **Solvent Addition:** To each vial, add a different solvent from the selection table above, ensuring the concentration of the diamine is consistent across all experiments.
- **Reaction Execution:** Place the vials in a temperature-controlled shaker or on a multi-position stir plate. Run the reactions at a predetermined temperature (e.g., room temperature, 50 °C,

80 °C) for a set period (e.g., 24 hours).

- Monitoring: At regular intervals (e.g., 2, 6, 24 hours), take a small aliquot from each reaction vial.
- Analysis: Analyze the aliquots by Thin Layer Chromatography (TLC) or Liquid Chromatography-Mass Spectrometry (LC-MS).[17][18]
 - TLC Analysis: Spot the starting material, the reaction mixture, and if available, an authentic sample of the desired product on the same plate. This allows for qualitative assessment of starting material consumption and product formation.[18]
 - LC-MS Analysis: This provides quantitative data on the conversion of starting material and the formation of products and byproducts, including the ratio of regioisomers.
- Selection: Based on the analysis, identify the solvent(s) that provide the highest conversion and selectivity to the desired product. Further optimization of temperature and concentration can then be performed in the selected solvent(s).

Protocol 2: Reaction Monitoring by Thin Layer Chromatography (TLC)

TLC is a rapid and effective technique for qualitatively monitoring the progress of a reaction.
[17]

- Prepare the TLC Chamber: Add a suitable solvent system (eluent) to the chamber to a depth of about 0.5 cm. A common starting point is a mixture of a non-polar solvent (e.g., hexanes) and a polar solvent (e.g., ethyl acetate).[17]
- Spot the Plate: On a silica gel TLC plate, use a capillary tube to apply small spots of:
 - Lane 1: Starting diamine
 - Lane 2: A co-spot of the starting diamine and the reaction mixture
 - Lane 3: The reaction mixture

- **Develop the Plate:** Place the TLC plate in the chamber and allow the eluent to travel up the plate until it is about 1 cm from the top.
- **Visualize:** Remove the plate, mark the solvent front, and visualize the spots under a UV lamp and/or by staining (e.g., with iodine or potassium permanganate).^[17]
- **Interpretation:** The disappearance of the starting material spot and the appearance of a new spot corresponding to the product indicate that the reaction is proceeding. The presence of multiple new spots suggests the formation of byproducts or regioisomers.

Visualizing the Optimization Workflow

The process of optimizing solvent choice can be visualized as a decision-making flowchart.

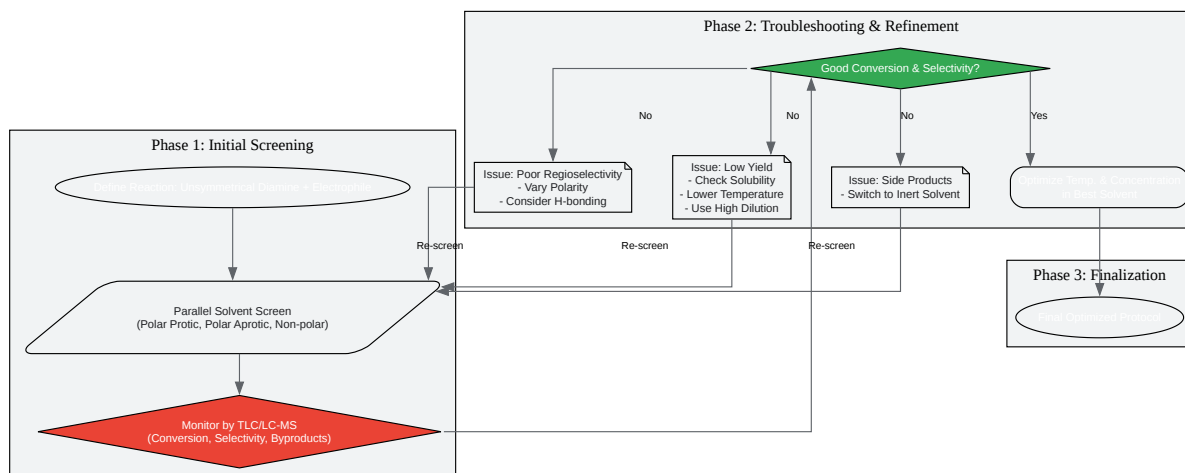

[Click to download full resolution via product page](#)

Caption: Workflow for solvent optimization in unsymmetrical diamine cyclization.

The following diagram illustrates the fundamental concept of how a solvent can differentially stabilize the transition states leading to two different regioisomers.

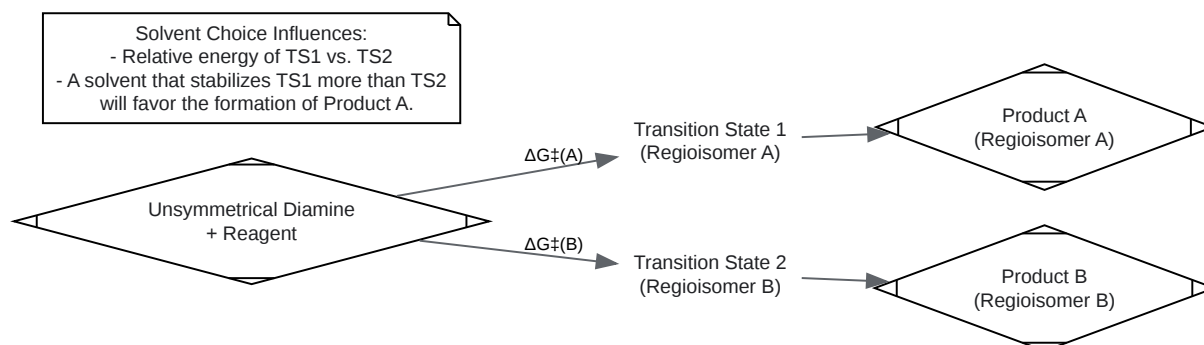

[Click to download full resolution via product page](#)

Caption: Solvent effects on transition state stabilization and regioselectivity.

References

- Reichardt, C., & Welton, T. (2011). *Solvents and Solvent Effects in Organic Chemistry* (4th ed.). John Wiley & Sons.
- MDPI. (2024). The Application of Green Solvents in the Synthesis of S-Heterocyclic Compounds—A Review. Retrieved from [\[Link\]](#)
- Wiley Online Library. (2025). Screening of Suitable Solvents in Organic Synthesis. Strategies for Solvent Selection. Retrieved from [\[Link\]](#)
- MDPI. (2022). New Screening Protocol for Effective Green Solvents Selection of Benzamide, Salicylamide and Ethenzamide. Retrieved from [\[Link\]](#)
- Semantic Scholar. (2022). New Screening Protocol for Effective Green Solvents Selection of Benzamide, Salicylamide and Ethenzamide. Retrieved from [\[Link\]](#)
- Wikipedia. (n.d.). Solvent effects. Retrieved from [\[Link\]](#)
- Wiley-VCH. (2003). *Solvents and Solvent Effects in Organic Chemistry* (Third Edition).
- ResearchGate. (2024). The Application of Green Solvents in the Synthesis of S-Heterocyclic Compounds—A Review. Retrieved from [\[Link\]](#)

- ACS Publications. (2022). Effect of Solvents on Proline Modified at the Secondary Sphere: A Multivariate Exploration. Retrieved from [[Link](#)]
- SciSpace. (2012). The Solvent Selection framework: solvents for organic synthesis, separation processes and ionic-organic synthesis. Retrieved from [[Link](#)]
- MDPI. (2023). Finding the Right Solvent: A Novel Screening Protocol for Identifying Environmentally Friendly and Cost-Effective Options for Benzenesulfonamide. Retrieved from [[Link](#)]
- International Journal of Pharmaceutical Sciences and Research. (n.d.). GREEN CHEMISTRY APPROACH TO THE SUSTAINABLE ADVANCEMENT TO THE SYNTHESIS OF HETEROCYCLIC CHEMISTRY.
- National Institutes of Health. (2022). Synthesis of Unsymmetrical Vicinal Diamines via Directed Hydroamination. Retrieved from [[Link](#)]
- MDPI. (2025). Green Strategies for the Synthesis of Heterocyclic Derivatives with Potential Against Neglected Tropical Diseases. Retrieved from [[Link](#)]
- ChemTalk. (2025). A Deep Dive into Common Organic Solvents. Retrieved from [[Link](#)]
- Wiley-VCH. (n.d.). Solvents and Solvent Effects in Organic Chemistry.
- Asian Journal of Green Chemistry. (n.d.). Effect of Solvents on Kinetics and Mechanistic Investigation of Highly Substituted Piperidines: Spectrometry Approaches.
- Semantic Scholar. (2021). Demonstration of Green Solvent Performance on O,S,N-Heterocycles Synthesis: Metal-Free Click Chemistry and Buchwald—Hartwig Coupling. Retrieved from [[Link](#)]
- ChemRxiv. (n.d.). Kinetic Solvent Effects in Organic Reactions. Retrieved from [[Link](#)]
- Royal Society of Chemistry. (n.d.). Quantitative study of solvent effects on the Menshutkin reaction between 1,4-diazabicyclo[2.2.2]octane and 2-chloroethylbenzene, 2-bromoethylbenzene, and 2-iodoethylbenzene. Part 2. Mixed solvents. Retrieved from [[Link](#)]
- PubMed. (2018). Role of Solvent Polarity and Hydrogen-Bonding on Excited-State Fluorescence of 3-[(E)-{4-[Dimethylamino]benzylidene}amino]-2-naphthoic Acid (DMAMN):

Isomerization vs Rotomerization. Retrieved from [[Link](#)]

- Organic Chemistry Portal. (2023). Regioselective Synthesis of Unsymmetrical Vicinal Diamines via Azidoimination of Alkenes with TMSN₃ and Ketimines. Retrieved from [[Link](#)]
- Washington State University. (n.d.). Monitoring Reactions by TLC. Retrieved from [[Link](#)]
- ResearchGate. (2025). Activatable self-reporting cyclization reaction for in-cell synthesis of cyclocyanines. Retrieved from [[Link](#)]
- National Institutes of Health. (2024). π - π stacking assisted regioselectivity regulation in palladium-catalyzed cyclization reactions: a theoretical study. Retrieved from [[Link](#)]
- Cooperative Organic Chemistry Student Laboratory Manual. (n.d.). Monitoring a Reaction. Retrieved from [[Link](#)]
- Master Organic Chemistry. (2012). Polar Protic? Polar Aprotic? Nonpolar? All About Solvents. Retrieved from [[Link](#)]
- ResearchGate. (2025). Activatable self-reporting cyclization reaction for in-cell synthesis of cyclocyanines. Retrieved from [[Link](#)]
- National Institutes of Health. (2025). Striking Impact of Solvent Polarity on the Strength of Hydrogen-Bonded Complexes: A Nexus Between Theory and Experiment. Retrieved from [[Link](#)]
- Office of Scientific and Technical Information. (2021). Influence of Solvent Structure and Hydrogen Bonding on Catalysis at Solid-Liquid Interfaces. Retrieved from [[Link](#)]
- YouTube. (2021). Solvent Effects on Reaction Rates | SN₁ vs SN₂, Polar Protic & Aprotic Solvents. Retrieved from [[Link](#)]
- Royal Society of Chemistry. (n.d.). Activatable self-reporting cyclization reaction for in-cell synthesis of cyclocyanines. Retrieved from [[Link](#)]
- ACS Publications. (2023). [3 + 2] Cycloadditions of Tertiary Amine N-Oxides and Silyl Imines as an Innovative Route to 1,2-Diamines. Retrieved from [[Link](#)]

- Journal of Applicable Chemistry. (n.d.).
- ResearchGate. (n.d.). Optimization of cyclization reaction. Retrieved from [[Link](#)]
- National Institutes of Health. (n.d.). Deciphering and reprogramming the cyclization regioselectivity in bifurcation of indole alkaloid biosynthesis. Retrieved from [[Link](#)]
- Journal of Heterocyclic Chemistry. (n.d.). Different Pathways for the Cyclocondensation Reactions of 1,2-Diamine and 1,2-Diketone.
- Sci-Hub. (n.d.).
- Royal Society of Chemistry. (n.d.). Multicomponent synthesis of unsymmetrical 1,2-diamines via photo-induced carbonyl alkylative amination. Retrieved from [[Link](#)]
- National Institutes of Health. (2023). Rational design of N-heterocyclic compound classes via regenerative cyclization of diamines. Retrieved from [[Link](#)]
- Royal Society of Chemistry. (n.d.). Visible light-induced intramolecular cyclization reactions of diamines: a new strategy to construct tetrahydroimidazoles. Retrieved from [[Link](#)]
- ACS Publications. (2024). Cascade Cyclization/Annulation of β -Enamino Diketones and o-Phenylenediamine: A Strategy to Access Pyrrole-fused 1,5-Benzodiazepines. Retrieved from [[Link](#)]
- Beilstein Journal of Organic Chemistry. (2016).
- PubMed. (2004). Diastereoselective [2+2]-cycloaddition reactions of unsymmetrical cyclic ketenes with imines: synthesis of modified prolines and theoretical study of the reaction mechanism. Retrieved from [[Link](#)]

Need Custom Synthesis?

BenchChem offers custom synthesis for rare earth carbides and specific isotopic labeling.

Email: info@benchchem.com or [Request Quote Online](#).

Sources

- [1. A Deep Dive into Common Organic Solvents | ChemTalk \[chemistrytalk.org\]](#)
- [2. jru-b.com \[jru-b.com\]](#)
- [3. Solvent effects - Wikipedia \[en.wikipedia.org\]](#)
- [4. osti.gov \[osti.gov\]](#)
- [5. masterorganicchemistry.com \[masterorganicchemistry.com\]](#)
- [6. m.youtube.com \[m.youtube.com\]](#)
- [7. pdf.benchchem.com \[pdf.benchchem.com\]](#)
- [8. Quantitative study of solvent effects on the Menshutkin reaction between 1,4-diazabicyclo\[2.2.2\]octane and 2-chloroethylbenzene, 2-bromoethylbenzene, and 2-iodoethylbenzene. Part 2. Mixed solvents - Journal of the Chemical Society, Perkin Transactions 2 \(RSC Publishing\) \[pubs.rsc.org\]](#)
- [9. cjcu.jlu.edu.cn \[cjcu.jlu.edu.cn\]](#)
- [10. mdpi.com \[mdpi.com\]](#)
- [11. researchgate.net \[researchgate.net\]](#)
- [12. mdpi.com \[mdpi.com\]](#)
- [13. New Screening Protocol for Effective Green Solvents Selection of Benzamide, Salicylamide and Ethenzamide - PMC \[pmc.ncbi.nlm.nih.gov\]](#)
- [14. semanticscholar.org \[semanticscholar.org\]](#)
- [15. mdpi.com \[mdpi.com\]](#)
- [16. ajgreenchem.com \[ajgreenchem.com\]](#)
- [17. s3.wp.wsu.edu \[s3.wp.wsu.edu\]](#)
- [18. Monitoring a Reaction – Cooperative Organic Chemistry Student Laboratory Manual \[openbooks.lib.msu.edu\]](#)
- [To cite this document: BenchChem. \[Technical Support Center: Optimizing Solvent Choice for Unsymmetrical Diamine Cyclization\]. BenchChem, \[2026\]. \[Online PDF\]. Available at: \[https://www.benchchem.com/product/b2540400/docs#technical-support-center-optimizing-solvent-choice-for-unsymmetrical-diamine-cyclization\]](#)

Disclaimer & Data Validity:

The information provided in this document is for Research Use Only (RUO) and is strictly not intended for diagnostic or therapeutic procedures. While BenchChem strives to provide

accurate protocols, we make no warranties, express or implied, regarding the fitness of this product for every specific experimental setup.

Technical Support: The protocols provided are for reference purposes. Unsure if this reagent suits your experiment?

Need Industrial/Bulk Grade? [Request Custom Synthesis Quote](#)

BenchChem

Our mission is to be the trusted global source of essential and advanced chemicals, empowering scientists and researchers to drive progress in science and industry.

Contact

Address: 3281 E Guasti Rd

Ontario, CA 91761, United States

Phone: (601) 213-4426

Email: info@benchchem.com

[Contact our Ph.D. Support Team for a compatibility check](#)