

Technical Support Center: Regioselective Functionalization of Piperidines

Author: BenchChem Technical Support Team. **Date:** April 2026

Compound of Interest

Compound Name: Methyl 4-(1-acetylpiperidin-4-yl)benzoate

CAS No.: 2490403-99-9

Cat. No.: B2539954

[Get Quote](#)

Core Directive & Strategy

Piperidine is the most common nitrogen heterocycle in FDA-approved drugs. However, its saturation renders it chemically inert compared to pyridine, making direct, regioselective functionalization a significant challenge.

The Central Challenge:

- C2 (Alpha): Electronically activated (adjacent to N) but prone to over-oxidation and racemization.
- C3 (Beta): Electronically deactivated (inductive withdrawal) and sterically unshielded.
- C4 (Gamma): Distal and difficult to distinguish from other methylene groups without directing groups.

This guide provides field-proven protocols to target each position selectively.

Decision Matrix: Select Your Target Position

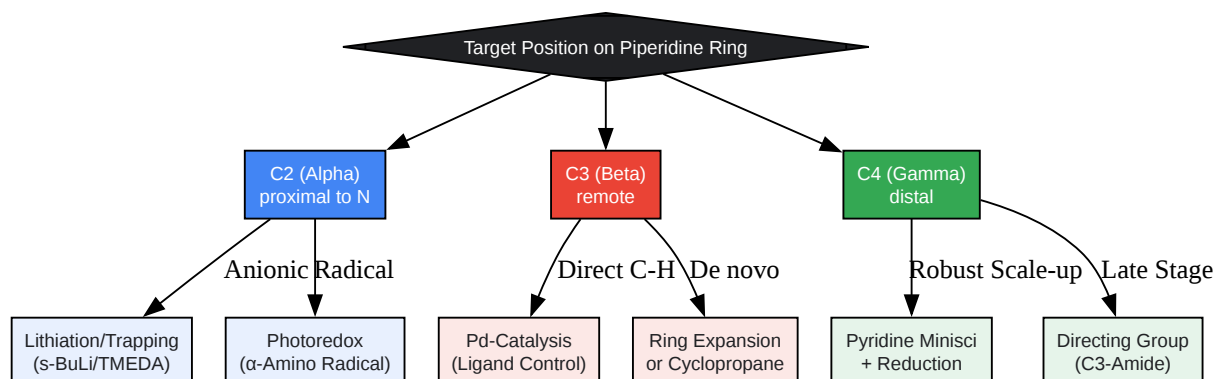

[Click to download full resolution via product page](#)

Figure 1: Strategic decision tree for selecting the optimal functionalization methodology based on the target carbon position.

Module 1: C2-Functionalization (The Alpha Position)

The C2 position is the most accessible due to the acidity of the

-proton adjacent to the nitrogen.

Method A: Lithiation-Trapping (Beak-O'Brien Protocol)

This is the gold standard for installing electrophiles at C2. It relies on the dipole-stabilized lithiation of

-Boc piperidine.

Protocol:

- Substrate:

 - Boc-piperidine (1.0 equiv).

- Reagent:

-BuLi (1.2 equiv) / TMEDA (1.2 equiv).

- Conditions: THF, -78 °C, 1-4 hours.
- Quench: Add electrophile (e.g., MeI, DMF, allyl bromide).

Critical Mechanism: The

-Boc group creates a dipole that directs the lithium to the equatorial

-proton. The resulting organolithium species is configurationally stable at -78 °C but racemizes rapidly upon warming.

Method B: Photoredox -Arylation

For coupling with aryl nitriles/halides, photoredox catalysis generates an

-amino radical that couples with electron-deficient arenes (Minisci-type mechanism on the radical cation).

Key Reagents:

- Catalyst: [Ir(ppy)₃] (1 mol%).
- Light Source: Blue LEDs.
- Additives: Quinuclidine (HAT agent).

Troubleshooting Guide: C2 Functionalization

Symptom	Probable Cause	Corrective Action
Racemic Product	Temperature fluctuation during lithiation.	Ensure internal probe monitors temperature. Do not allow °C before electrophile addition.
Low Yield (Lithiation)	Incomplete deprotonation.	Use fresh -BuLi (titrate before use). Ensure TMEDA is dry and distilled.
Ring Opening	"Parosec" elimination.	Avoid warming the lithiated species above -40 °C without an electrophile present.
C2 vs C6 Mixtures	Over-reaction.	Use strict 1.0 : 1.1 stoichiometry of substrate to base.

Module 2: C3-Functionalization (The Beta Position)

Direct C3 functionalization is challenging because it lacks the electronic activation of C2.

Method A: Ligand-Controlled Pd-Catalyzed Arylation

Standard Pd-catalysis favors

-arylation (C2). However, using specific bulky, electron-rich ligands can switch selectivity to the -position (C3) via a migratory insertion mechanism.

The "Switch" Ligand:

- Ligand: 2-(Diisopropylphosphanyl)-1-phenylpyrrole (and related biaryl phosphines).
- Mechanism: The flexible ligand allows the palladium to migrate from the initial -agostic interaction to the

-position before reductive elimination.

Protocol Summary:

- Catalyst: Pd(OAc)₂ / Ligand (2:1 ratio).
- Base: Cs₂CO₃.
- Solvent: Xylene, 130 °C.
- Selectivity: Can achieve >10:1 C3:C2 selectivity.

Method B: Indirect Synthesis (Cyclopropane Ring Opening)

For high enantioselectivity, it is often more reliable to synthesize the piperidine ring rather than functionalize it.

- Workflow: Pyridine reduction

Tetrahydropyridine

Cyclopropanation

Reductive ring opening (cleaves the bond distal to N, placing substituent at C3).

Module 3: C4-Functionalization (The Gamma Position)

Method A: The "Pyridine Route" (Minisci + Reduction)

The most robust way to access C4-substituted piperidines is to functionalize the corresponding pyridine first and then reduce it.

Step 1: Minisci Reaction

- Substrate: Pyridine (protonated with TFA).
- Radical Source: Carboxylic acid + AgNO₃ + (NH₄)₂S₂O₈.

- Selectivity: Protonated pyridines react at C2 and C4.[1][2] Blocking C2 (e.g., with methyl groups) or using specific radical precursors forces C4 substitution.

Step 2: Hydrogenation

- Conditions: H₂ / PtO₂ or Pd/C in acidic methanol.
- Result: Fully saturated C4-substituted piperidine.

Method B: Directing Group Strategy

If you must functionalize an existing piperidine ring at C4:

- Directing Group: Install an amide at C3 (e.g., 8-aminoquinoline).
- Catalyst: Pd(OAc)₂.
- Outcome: The DG directs C-H activation to the cis-C4 position.

Troubleshooting Guide: C4 Functionalization

Symptom	Probable Cause	Corrective Action
C2/C4 Mixture (Minisci)	Lack of steric control.	Use a bulky radical source (e.g., tert-butyl) or block C2 positions with methyls/halogens.
Polysubstitution	Radical concentration too high.	Add the oxidant and radical precursor portion-wise (syringe pump) to keep radical concentration low.
Low Yield (Direct C4)	Distal C-H bond is inert.	Ensure the C3-directing group forms a rigid 5-membered chelate with Pd.

Visualizing the Selectivity Logic

The following diagram illustrates the mechanistic divergence between C2 (Lithiation) and C3 (Ligand-Controlled) pathways.

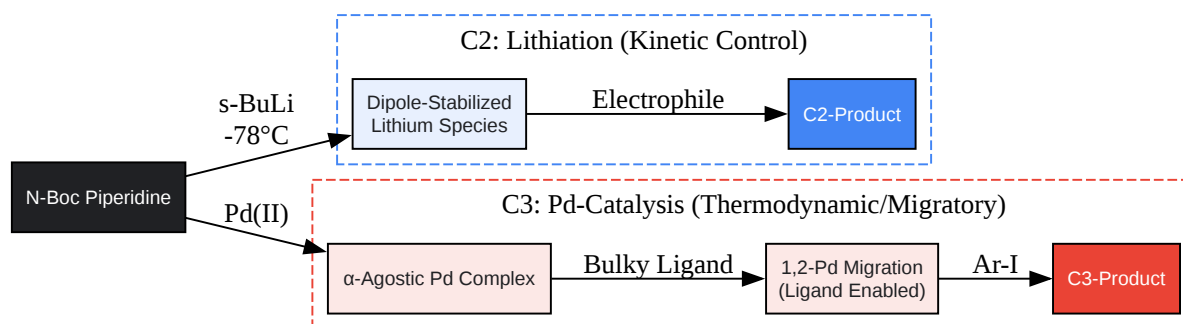

[Click to download full resolution via product page](#)

Figure 2: Mechanistic divergence. C2 functionalization is driven by kinetic deprotonation stabilized by the N-Boc dipole. C3 functionalization requires a transition-metal catalyst to initially engage at C2 and then migrate to C3, a process enabled by specific ligand architecture.

FAQ: Common User Queries

Q1: Why am I getting the C2-product when attempting C3-arylation?

- Answer: This is likely a ligand issue. Standard phosphines (like PPh_3 or XPhos) favor the electronically activated C2 position. You must use a ligand capable of promoting the 1,2-palladium migration, such as 2-(diisopropylphosphanyl)-1-phenylpyrrole. Also, ensure the reaction temperature is high enough ($>120^\circ\text{C}$) to overcome the activation energy for migration.

Q2: Can I use $n\text{-BuLi}$ instead of $s\text{-BuLi}$ for N-Boc piperidine lithiation?

- Answer: Generally, no.

$n\text{-BuLi}$ is nucleophilic enough to attack the Boc carbonyl group (acting as a nucleophile rather than a base), leading to decomposition.

$n\text{-BuLi}$ is more basic and sterically hindered, favoring deprotonation over nucleophilic attack.

Q3: How do I remove the 8-aminoquinoline directing group after C4 functionalization?

- Answer: The directing group can be removed via hydrolysis or reduction. A common method is treatment with $\text{Boc}_2\text{O}/\text{DMAP}$ followed by $\text{LiOH}/\text{H}_2\text{O}_2$, or reduction with SmI_2 if the substrate is sensitive to oxidation.

References

- Beak, P., & Lee, W. K. (1994). α -Lithioamine Synthetic Equivalents: Syntheses of Diastereoisomers from the Boc Derivatives of Cyclic Amines. *Journal of Organic Chemistry*. [Link](#)
- Beng, T. K., & Gawley, R. E. (2010). Application of Catalytic Dynamic Resolution of N-Boc-2-lithiopiperidine to the Asymmetric Synthesis of 2-Aryl and 2-Vinyl Piperidines. *Organic Letters*. [Link](#)
- Baudoin, O., et al. (2015). Palladium-Catalyzed β -Selective $\text{C}(\text{sp}^3)\text{-H}$ Arylation of N-Boc-Piperidines.[3][4] *Organic Syntheses*. [2][5] [Link](#)
- McNally, A., Prier, C. K., & MacMillan, D. W. C. (2011). Discovery of an α -Amino C-H Arylation Reaction Using the Strategy of Accelerated Serendipity. *Science*. [Link](#)
- Antermite, D., & Bull, J. A. (2023). On the Mechanism and Selectivity of Palladium-Catalyzed $\text{C}(\text{sp}^3)\text{-H}$ Arylation of Pyrrolidines and Piperidines at Unactivated C4 Positions. *ACS Catalysis*. [Link](#)

Need Custom Synthesis?

BenchChem offers custom synthesis for rare earth carbides and specific isotopic labeling.

Email: info@benchchem.com or [Request Quote Online](#).

Sources

- 1. scispace.com [scispace.com]
- 2. Recent Advances in the C-H -Functionalization of the Distal Positions in Pyridines and Quinolines - PMC [[pmc.ncbi.nlm.nih.gov](https://pubmed.ncbi.nlm.nih.gov)]

- [3. Ligand-controlled \$\beta\$ -selective C\(sp³\)–H arylation of N-Boc-piperidines - Chemical Science \(RSC Publishing\) \[pubs.rsc.org\]](#)
- [4. chemrxiv.org \[chemrxiv.org\]](#)
- [5. BJOC - Opportunities and challenges for direct C–H functionalization of piperazines \[beilstein-journals.org\]](#)
- To cite this document: BenchChem. [Technical Support Center: Regioselective Functionalization of Piperidines]. BenchChem, [2026]. [Online PDF]. Available at: [\[https://www.benchchem.com/product/b2539954/docs#technical-support-center-regioselective-functionalization-of-piperidines\]](https://www.benchchem.com/product/b2539954/docs#technical-support-center-regioselective-functionalization-of-piperidines)

Disclaimer & Data Validity:

The information provided in this document is for Research Use Only (RUO) and is strictly not intended for diagnostic or therapeutic procedures. While BenchChem strives to provide accurate protocols, we make no warranties, express or implied, regarding the fitness of this product for every specific experimental setup.

Technical Support: The protocols provided are for reference purposes. Unsure if this reagent suits your experiment?

Need Industrial/Bulk Grade? [Request Custom Synthesis Quote](#)

BenchChem

Our mission is to be the trusted global source of essential and advanced chemicals, empowering scientists and researchers to drive progress in science and industry.

Contact

Address: 3281 E Guasti Rd
Ontario, CA 91761, United States
Phone: (601) 213-4426
Email: info@benchchem.com

Contact our Ph.D. Support Team for a compatibility check