

Comparing metabolic stability of alpha-peptides vs beta-peptides

Author: BenchChem Technical Support Team. **Date:** April 2026

Compound of Interest

Compound Name: (S)-3-N-Cbz-Amino-pentanoic acid

CAS No.: 271600-24-9

Cat. No.: B2535346

[Get Quote](#)

Metabolic Stability Guide: Alpha-Peptides vs. Beta-Peptides[1]

Executive Summary

In drug development, the therapeutic potential of natural

-peptides is frequently compromised by rapid proteolytic degradation in vivo.

-peptides—peptidomimetics containing an extra methylene group in the backbone—have emerged as a superior alternative for metabolic stability.

The Verdict: While

-peptides typically exhibit serum half-lives (

) ranging from minutes to hours,

-peptides demonstrate near-total resistance to major peptidases (trypsin, chymotrypsin, pepsin), often retaining structural integrity for days to weeks. This guide details the structural

causality of this stability and provides a validated LC-MS protocol for quantifying these differences.

Structural Basis of Stability

The fundamental difference lies in the backbone chemistry. Natural

-peptides differ from

-peptides by a single methylene (

) insertion.^{[1][2]}

- -Peptides: Amino group attached to the

atom.^{[3][4]}

- -Peptides: Amino group attached to the

atom.^{[3][1][2]} This can occur as a

-substitution (side chain on

) or

-substitution (side chain on

).

This homologation alters the backbone torsion angles, allowing

-peptides to fold into unique stable secondary structures (e.g., the 14-helix, stabilized by H-bonds between residues

and

) that are sterically incompatible with the active sites of endogenous proteases.

Diagram 1: Backbone Homologation Logic



[Click to download full resolution via product page](#)

Figure 1: Chemical comparison showing the methylene insertion that renders

-peptides unrecognizable to standard proteases.

Comparative Enzymatic Stability Profile

The following data synthesizes stability profiles across standard proteolytic assays.

-peptides do not merely degrade slower; they often function as "orthogonal" molecules to the biological enzymatic machinery.

Table 1: Half-Life () Comparison

| Enzyme / Medium | Substrate Class | -Peptide | -Peptide | Notes |
|-----------------|---------------------------|--------------|-----------------------|--|
| Human Serum | Mixed | 10 – 30 mins | > 48 hours | -peptides often show 0% degradation at 24h. |
| Trypsin | Basic Residues (Lys/Arg) | < 15 mins | No Cleavage | Trypsin requires specific backbone geometry for the catalytic triad. |
| Chymotrypsin | Hydrophobic (Phe/Tyr/Trp) | < 15 mins | No Cleavage | Steric clash prevents hydrolysis of the scissile bond. |
| Pepsin | Acidic/General | ~ 30 mins | No Cleavage | Stable even at low pH (gastric simulation). |
| Pronase | Non-specific mixture | Minutes | Very Slow / Resistant | Only aggressive bacterial cocktails show minor activity. |

Data Source: Synthesized from Seebach et al. and Gellman et al. studies (See References).

Mechanistic Insight: The "Lock and Key" Failure

Why are they stable? Proteolysis is a stereoelectronic event. For a protease to cleave a bond:

[3]

- The substrate must bind (affinity).

- The scissile amide bond must align precisely with the enzyme's catalytic triad (e.g., Ser-His-Asp).

-peptides may bind to the protease (acting as competitive inhibitors), but the extra

group shifts the carbonyl carbon away from the nucleophilic attack of the enzyme's active site serine or water molecule.

Diagram 2: Mechanism of Proteolytic Resistance

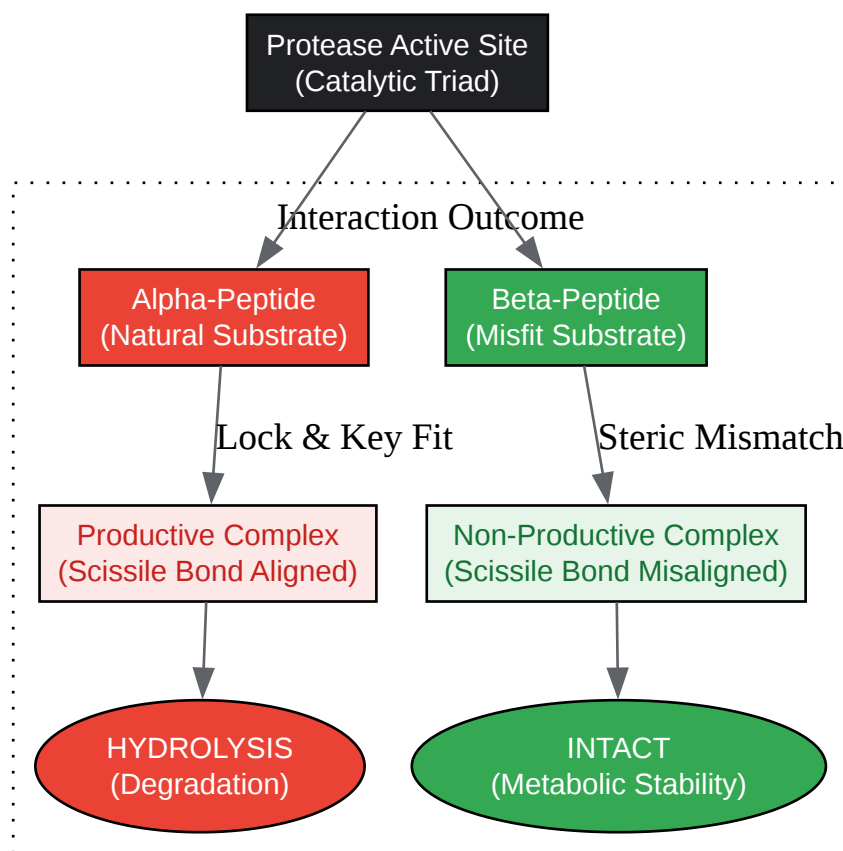

[Click to download full resolution via product page](#)

Figure 2: The extra backbone methylene prevents the formation of the transition state required for peptide bond hydrolysis.

Experimental Protocol: Serum Stability Assay (LC-MS)

To validate the stability claims above, researchers must perform a kinetic study in biological matrix. This protocol uses LC-MS for sensitive, label-free quantification.

Materials:

- Matrix: Pooled Human Serum (commercial) or Rat Plasma.
- Test Article:
 - peptide (control) and
 - peptide analog (10 mM DMSO stock).
- Internal Standard (IS): Stable isotope-labeled peptide or structural analog (crucial for normalization).
- Quenching Agent: Acetonitrile (ACN) with 1% Formic Acid (FA). Note: ACN is preferred over TCA for LC-MS to prevent ion suppression.

Workflow:

- Preparation: Dilute Test Article in pre-warmed () Serum to a final concentration of ~10 . (Keep DMSO < 1%).
- Incubation: Incubate mixture in a water bath at .
- Sampling: At defined timepoints (), remove 50 aliquots.
- Quenching: Immediately add aliquot to 150 ice-cold Quenching Agent containing the Internal Standard. Vortex vigorously for 30s.

- Precipitation: Centrifuge at 14,000 x g for 15 mins at
to pellet serum proteins.
- Analysis: Inject supernatant onto RP-HPLC coupled to ESI-MS. Monitor parent ion via SIM or MRM mode.

Calculation:

Diagram 3: Assay Workflow

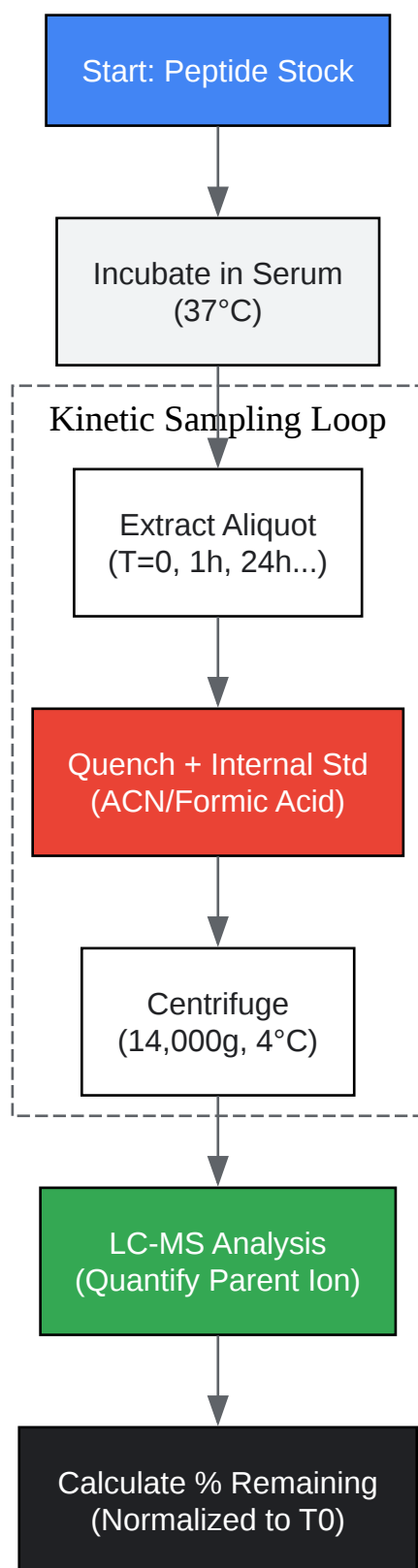

[Click to download full resolution via product page](#)

Figure 3: Step-by-step LC-MS workflow for determining metabolic half-life.

Therapeutic Implications

The metabolic stability of

-peptides offers specific advantages in drug design:

- **Extended Half-Life:** Reduces dosing frequency from multiple times daily (common for -peptides like insulin) to potentially once daily or weekly.
- **Oral Bioavailability:** Resistance to gastric pepsin and intestinal trypsin opens the possibility of oral administration, bypassing the need for injection.
- **Target Specificity:** While stable, -peptides can be designed to mimic the helix of -peptides, allowing them to bind natural receptors (e.g., GPCRs) without being degraded by the associated enzymes.[4]

References

- Seebach, D., et al. (1996). "Beta-Peptides: Synthesis by Arndt-Eistert homologation with concomitant peptide coupling. Structure determination of the beta-hexapeptide H-beta-HVal-beta-HAla-beta-HLeu-OH in solution and in the solid state." *Helvetica Chimica Acta*. [5]
- Hook, D. F., et al. (2005). [3] "The proteolytic stability of 'designed' beta-peptides containing alpha-peptide-bond mimics and of mixed alpha,beta-peptides." [3][6] *Chemistry & Biodiversity*. [3][5]
- Steer, D. L., et al. (2002). "Beta-amino acids: versatile peptidomimetics." *Current Medicinal Chemistry*.
- Frackenpohl, J., et al. (2001). "The outstanding biological stability of beta- and gamma-peptides toward proteolytic enzymes: an in vitro investigation with fifteen peptidases." *ChemBioChem*.
- Gellman, S. H. (1998). "Foldamers: A Manifesto." *Accounts of Chemical Research*.

Need Custom Synthesis?

BenchChem offers custom synthesis for rare earth carbides and specific isotopic labeling.

Email: info@benchchem.com or [Request Quote Online](#).

Sources

- [1. researchgate.net \[researchgate.net\]](https://www.researchgate.net)
- [2. pubs.acs.org \[pubs.acs.org\]](https://pubs.acs.org)
- [3. The proteolytic stability of 'designed' beta-peptides containing alpha-peptide-bond mimics and of mixed alpha,beta-peptides: application to the construction of MHC-binding peptides - PubMed \[pubmed.ncbi.nlm.nih.gov\]](#)
- [4. A comparison of the different helices adopted by \$\alpha\$ - and \$\beta\$ -peptides suggests different reasons for their stability - PMC \[pmc.ncbi.nlm.nih.gov\]](#)
- [5. ethz.ch \[ethz.ch\]](https://www.ethz.ch)
- [6. Folding and function in \$\alpha/\beta\$ -peptides: Targets and therapeutic applications - PMC \[pmc.ncbi.nlm.nih.gov\]](#)
- To cite this document: BenchChem. [Comparing metabolic stability of alpha-peptides vs beta-peptides]. BenchChem, [2026]. [Online PDF]. Available at: [\[https://www.benchchem.com/product/b2535346/docs#comparing-metabolic-stability-of-alpha-peptides-vs-beta-peptides\]](https://www.benchchem.com/product/b2535346/docs#comparing-metabolic-stability-of-alpha-peptides-vs-beta-peptides)

Disclaimer & Data Validity:

The information provided in this document is for Research Use Only (RUO) and is strictly not intended for diagnostic or therapeutic procedures. While BenchChem strives to provide accurate protocols, we make no warranties, express or implied, regarding the fitness of this product for every specific experimental setup.

Technical Support: The protocols provided are for reference purposes. Unsure if this reagent suits your experiment?

Need Industrial/Bulk Grade? [Request Custom Synthesis Quote](#)

BenchChem

Our mission is to be the trusted global source of essential and advanced chemicals, empowering scientists and researchers to drive progress in science and industry.

Contact

Address: 3281 E Guasti Rd

Ontario, CA 91761, United States

Phone: (601) 213-4426

Email: info@benchchem.com

[Contact our Ph.D. Support Team for a compatibility check](#)