

Technical Support Center: Controlling Regioselectivity in 5-Bromo-Pyridin-2-one Functionalization

Author: BenchChem Technical Support Team. **Date:** April 2026

Compound of Interest

Compound Name:	5-Bromo-6-oxo-1,6-dihydropyridine-2-carbonitrile
CAS No.:	1780045-62-6
Cat. No.:	B2534667

[Get Quote](#)

Prepared by: Gemini, Senior Application Scientist

Welcome to the technical support center for the regioselective functionalization of 5-bromopyridin-2-one. This guide is designed for researchers, medicinal chemists, and drug development professionals to navigate the complexities of this versatile heterocyclic scaffold. Here, we provide in-depth troubleshooting guides, frequently asked questions (FAQs), and validated protocols to help you achieve predictable and high-yielding transformations.

Understanding the Reactivity of 5-Bromo-Pyridin-2-one

5-Bromo-pyridin-2-one is a privileged heterocyclic core found in numerous bioactive compounds and pharmaceutical agents.^{[1][2]} Its utility stems from multiple reactive sites that can be selectively functionalized. However, this same feature presents a significant challenge: controlling regioselectivity. The molecule exists in tautomeric equilibrium with 5-bromo-2-

hydroxypyridine, and its electronics are complex, with both electron-rich and electron-deficient positions.^{[1][2][3]}

Key Reactive Sites:

- N1-Position (Amide): Nucleophilic and prone to alkylation/arylation.
- O-Position (Enol): Nucleophilic, creating competition with N-functionalization.
- C3 and C5 Positions: Electron-rich due to resonance, making them susceptible to electrophilic attack.^{[1][2]}
- C4 and C6 Positions: Electron-deficient, favoring reactions with nucleophiles.^{[1][2]}
- C5-Br Bond: A handle for transition-metal-catalyzed cross-coupling reactions.^[4]

Understanding these intrinsic properties is the first step toward designing successful and selective functionalization strategies.

Frequently Asked Questions (FAQs)

Q1: What is the primary challenge when alkylating 5-bromo-pyridin-2-one?

The main challenge is the competition between N-alkylation and O-alkylation due to the amide-enol tautomerism.^{[3][5][6]} The outcome is highly dependent on reaction conditions, including the choice of base, solvent, and the nature of the alkylating agent (electrophile).^{[5][6][7]} Often, reactions yield a mixture of N- and O-alkylated isomers, complicating purification and reducing the yield of the desired product.^{[6][8]}

Q2: How can I confirm if I have the N- or O-alkylated product?

Unequivocal structure determination is critical. A combination of 1D and 2D NMR spectroscopy techniques is the most reliable method.^{[8][9]}

- HMBC (Heteronuclear Multiple Bond Correlation): Look for a 3-bond correlation from the N-CH₂ protons to the C2 and C6 carbons of the pyridone ring. An O-CH₂ group will typically show a correlation to the C2 carbon only.

- ROESY/NOESY (Rotating/Nuclear Overhauser Effect Spectroscopy): A cross-peak between the protons of the alkyl group (e.g., N-CH₂) and the C6-H of the pyridone ring is strong evidence for N-alkylation.[9][10]
- ¹³C NMR: The chemical shift of the C2 carbon can also be indicative, though prediction models should be used with care.[8]

Q3: Beyond N/O alkylation and C5-coupling, what are the other key sites for functionalization?

Direct C-H functionalization of the pyridone ring is a powerful strategy for introducing complexity.[1][2] The primary targets are:

- C3-Position: An electron-rich site, often targeted via radical or electrophilic metalation pathways.[1][2]
- C6-Position: The most electron-deficient carbon, requiring specific catalytic systems, such as Ni/Al cooperative catalysis, for functionalization with nucleophiles like alkenes or alkyl groups.[1][2]
- C4-Position: Generally less reactive for C-H functionalization but can be targeted if more reactive sites are blocked.[1]

Q4: What is the purpose of the bromine atom at the C5 position?

The C5-bromo substituent is an exceptionally versatile synthetic handle, primarily used for transition-metal-catalyzed cross-coupling reactions.[4] This allows for the introduction of a wide variety of aryl, heteroaryl, alkyl, and alkynyl groups via reactions like Suzuki, Negishi, and Sonogashira couplings.[4][11][12] This position is electronically distinct from the other C-H bonds, allowing for chemoselective functionalization.

Troubleshooting Guides

This section addresses specific experimental failures in a question-and-answer format, providing causal analysis and actionable solutions.

Guide 1: Poor Selectivity in N- vs. O-Alkylation

Problem: "My reaction with an alkyl halide produced a mixture of N- and O-alkylated 5-bromopyridin-2-one, with the O-alkylated isomer being the major product. How can I selectively synthesize the N-alkylated derivative?"

Analysis: The ratio of N- to O-alkylation is governed by the principles of Hard and Soft Acid and Base (HSAB) theory and kinetic versus thermodynamic control. The pyridone anion is an ambident nucleophile. The nitrogen is a "softer" nucleophilic center, while the oxygen is "harder."

Solutions:

- Modify the Alkylating Agent:
 - Favor N-Alkylation (Soft Electrophiles): Use alkylating agents with soft leaving groups, such as alkyl iodides (e.g., methyl iodide).[7] These react preferentially at the soft nitrogen center.
 - Favor O-Alkylation (Hard Electrophiles): Use alkylating agents with hard leaving groups, such as dimethyl sulfate or methyl triflate ("Magic Methyl").[7] These react at the hard oxygen center.
- Change the Base and Solvent System:
 - For N-Alkylation: Use a strong, non-coordinating base like sodium hydride (NaH) or potassium carbonate (K_2CO_3) in a polar aprotic solvent like DMF or THF.[10] These conditions generate a "free" pyridone anion, where the more nucleophilic nitrogen atom is favored to react.
 - For O-Alkylation: Using silver salts (e.g., Ag_2CO_3) can favor O-alkylation. The silver cation coordinates to the nitrogen lone pair, leaving the oxygen as the more accessible nucleophilic site.[6]
- Control Reaction Temperature:
 - Lower temperatures often favor the kinetically controlled N-alkylation product. Running the deprotonation at 0 °C and the alkylation at room temperature or slightly elevated temperatures (e.g., 70 °C) can improve N-selectivity.[9]

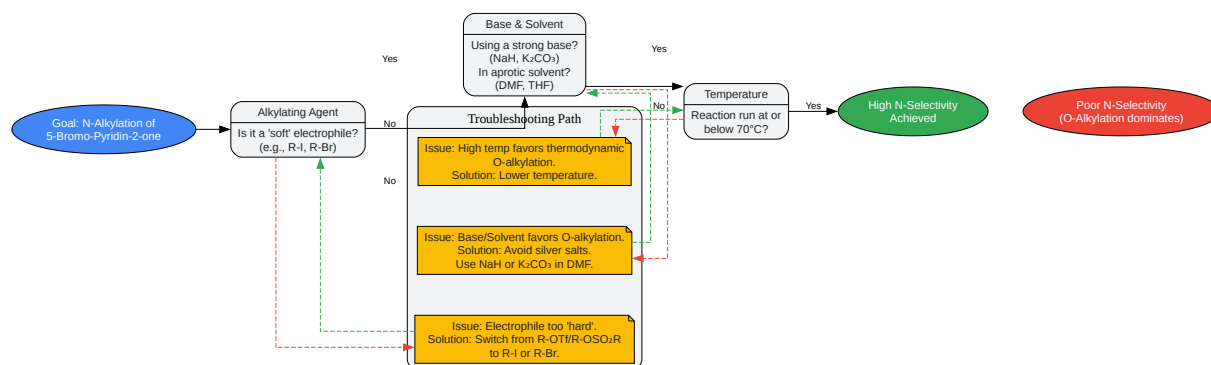

[Click to download full resolution via product page](#)

Decision workflow for achieving selective N-alkylation.

Guide 2: Failure in C5-Position Suzuki Cross-Coupling

Problem: "I am attempting a Suzuki coupling at the C5-bromo position with an arylboronic acid, but I am observing low conversion, significant starting material degradation, or formation of a homocoupled biaryl product."

Analysis: Suzuki cross-coupling reactions are complex catalytic cycles involving oxidative addition, transmetalation, and reductive elimination.[11] Failure can occur at any stage and is often related to catalyst activity, reagent quality, or suboptimal reaction conditions.[13]

Solutions:

- Verify Reagent and System Integrity:
 - Atmosphere: Ensure the reaction is run under a strictly inert atmosphere (Argon or Nitrogen). Oxygen can deactivate the Palladium(0) catalyst.[13]
 - Solvent: Use anhydrous, degassed solvents. Water content can affect the base and the stability of the catalyst. A common solvent system is 1,4-dioxane/water.[4]
 - Reagent Purity: Impurities in the 5-bromo-pyridin-2-one or the boronic acid can poison the catalyst.[13] Boronic acids are prone to dehydration to form boroxines; use fresh or properly stored material.
- Optimize the Catalytic System:
 - Palladium Precursor: Pd(PPh₃)₄ is often effective.[4] Other common precursors include Pd(OAc)₂ and Pd₂(dba)₃, which require the addition of phosphine ligands.[14][15]
 - Ligand Choice: If using a precursor like Pd(OAc)₂, the ligand is critical. Electron-rich, bulky phosphine ligands (e.g., SPhos, XPhos) often accelerate the reaction and stabilize the catalyst.
 - Catalyst Loading: Low catalyst loading can lead to incomplete reactions. While typical loadings are 1-5 mol%, problematic couplings may require optimization.[16] Conversely, excessively high loading can sometimes promote side reactions.
- Screen Bases and Temperature:
 - Base: The base is crucial for activating the boronic acid in the transmetalation step. K₃PO₄ is a common and effective choice.[4] Other bases like K₂CO₃ or Cs₂CO₃ can be screened.
 - Temperature: Most Suzuki couplings on this scaffold require heating (e.g., 85-95 °C).[4] If degradation is observed, try lowering the temperature and extending the reaction time. If conversion is low, a higher temperature may be necessary.

Component	Recommended Reagent/Condition	Rationale & Troubleshooting Tip
Bromide	5-Bromo-N-alkyl-pyridin-2-one	Ensure high purity. N-H pyridones can sometimes interfere with the catalyst.
Boronic Acid	Aryl-B(OH) ₂ (1.1-1.5 equiv.)	Use fresh reagent to avoid boroxine formation.
Catalyst	Pd(PPh ₃) ₄ (5 mol %)	A reliable choice. If it fails, try a Pd(OAc) ₂ /SPhos system.
Base	K ₃ PO ₄ (2-3 equiv.)	A strong base is needed for transmetalation. Ensure it is finely ground and dry.
Solvent	1,4-Dioxane / H ₂ O (e.g., 4:1 v/v)	Must be thoroughly degassed to remove oxygen.
Temperature	85-95 °C	Balance between reaction rate and thermal stability of reactants/catalyst.

Guide 3: Lack of Regioselectivity in C-H Functionalization

Problem: "I want to introduce an aryl group at the C3 position of N-methyl-5-bromo-pyridin-2-one, but my reaction is non-selective or fails completely."

Analysis: The intrinsic electronic biases of the pyridone ring make the C3 and C5 positions electron-rich and the C4 and C6 positions electron-deficient.^{[1][2]} Achieving selectivity requires overcoming these natural tendencies with a well-designed strategy, often involving directing groups or specialized catalysts.

Solutions:

- C3-Selective Functionalization:

- Strategy: This electron-rich site is a good target for reactions proceeding via an electrophilic pathway or a radical mechanism.
- Methodology: Nickel-catalyzed radical alkylation with α -bromo carbonyl compounds has shown excellent C3-selectivity.^{[1][2]} For arylation, conditions must be carefully chosen to favor electrophilic metalation at this site.
- C6-Selective Functionalization:
 - Strategy: This is the most electron-deficient C-H bond, making it a target for nucleophilic attack.
 - Methodology: A cooperative Ni/Al catalytic system has been successfully used for C6-selective alkenylation and alkylation.^{[1][2]} The Lewis acidic aluminum component coordinates to the carbonyl oxygen, increasing the electrophilicity of the C6 position and directing the nickel-catalyzed C-H activation.
- Use of Directing Groups:
 - Strategy: Installing a removable directing group onto the pyridone can override the ring's intrinsic reactivity and force functionalization at a specific site.^{[17][18]}
 - Methodology: A group attached to the N1 position can direct ortho-metalation to the C6 position. While less common for C3/C4, this is a powerful and general strategy in heterocycle chemistry for achieving otherwise difficult transformations.^{[17][19]}

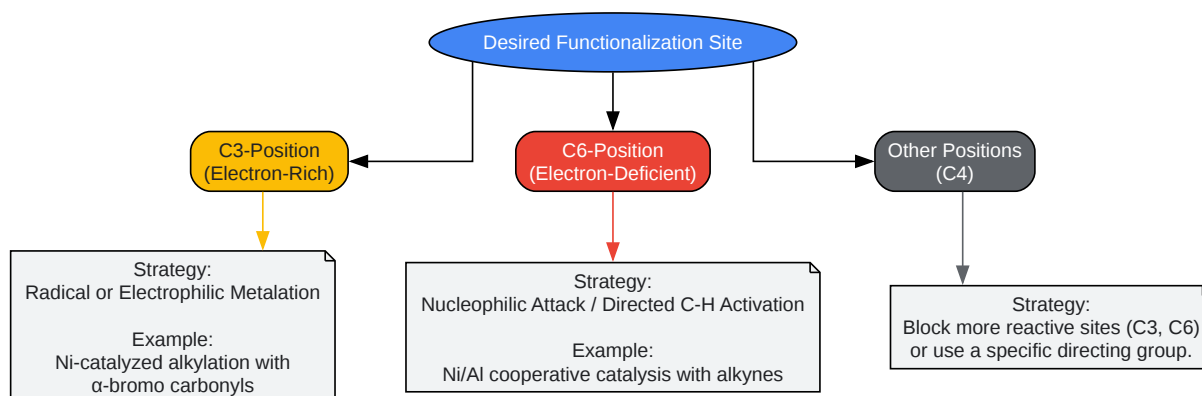

[Click to download full resolution via product page](#)

Strategic approaches for site-selective C-H functionalization.

Key Experimental Protocols

Protocol 1: Selective N-Alkylation of 5-Bromo-pyridin-2-one

This protocol is optimized for selective N-alkylation using a standard alkyl iodide.

- **Setup:** To a flame-dried, three-neck round-bottom flask under an argon atmosphere, add 5-bromo-pyridin-2-one (1.0 equiv.).
- **Solvent Addition:** Add anhydrous N,N-dimethylformamide (DMF) to create a 0.2 M solution.
- **Deprotonation:** Cool the flask to 0 °C in an ice bath. Add sodium hydride (NaH, 60% dispersion in mineral oil, 1.2 equiv.) portion-wise over 10 minutes.
- **Stirring:** Allow the mixture to stir at 0 °C for 30 minutes, then warm to room temperature and stir for an additional 30 minutes. The solution should become homogeneous.
- **Alkylation:** Add the alkyl iodide (1.1 equiv.) dropwise via syringe.

- Reaction: Heat the reaction mixture to 70 °C and monitor by TLC or LC-MS until the starting material is consumed (typically 2-6 hours).
- Workup: Cool the reaction to room temperature and carefully quench by the slow addition of saturated aqueous NH₄Cl solution. Extract the product with ethyl acetate (3x).
- Purification: Combine the organic layers, wash with brine, dry over Na₂SO₄, filter, and concentrate under reduced pressure. Purify the crude product by flash column chromatography (e.g., hexanes/ethyl acetate gradient) to yield the N-alkylated product.
- Validation: Confirm the structure and regioselectivity using ¹H NMR, ¹³C NMR, and 2D NMR (HMBC, ROESY) as described in the FAQ section.[\[8\]](#)[\[9\]](#)

Protocol 2: C5-Arylation via Suzuki-Miyaura Cross-Coupling

This protocol provides a general procedure for the Suzuki coupling at the C5-bromo position.

- Setup: To a Schlenk flask, add N-alkyl-5-bromo-pyridin-2-one (1.0 equiv.), the desired arylboronic acid (1.2 equiv.), potassium phosphate (K₃PO₄, 2.5 equiv.), and tetrakis(triphenylphosphine)palladium(0) [Pd(PPh₃)₄] (0.05 equiv.).[\[4\]](#)
- Inert Atmosphere: Evacuate and backfill the flask with argon three times.
- Solvent Addition: Add a degassed mixture of 1,4-dioxane and water (4:1 v/v) to create a 0.1 M solution based on the pyridinone.[\[4\]](#)
- Reaction: Heat the mixture to 90 °C with vigorous stirring. Monitor the reaction progress by TLC or LC-MS (typically 12-18 hours).[\[4\]](#)
- Workup: After completion, cool the reaction to room temperature and dilute with ethyl acetate. Filter the mixture through a pad of Celite® to remove the palladium catalyst and inorganic salts.
- Extraction: Transfer the filtrate to a separatory funnel, wash with water and then with brine.

- Purification: Dry the organic layer over anhydrous Na_2SO_4 , filter, and concentrate in vacuo. Purify the residue by flash column chromatography to isolate the C5-arylated product.

References

- ChemInform Abstract: Regioselective Synthesis of Two Types of Highly Substituted 2-Pyridones Through Similar Multicomponent Reactions. ResearchGate. Available at: [\[Link\]](#)
- Regioselectivity and Mechanism of Synthesizing N-Substituted 2-Pyridones and 2-Substituted Pyridines via Metal-Free C-O and C-N Bond-Cleaving of Oxazoline[3,2-a]pyridiniums. PubMed. Available at: [\[Link\]](#)
- Efficient, mild and completely regioselective synthesis of substituted pyridines. Chemical Communications (RSC Publishing). Available at: [\[Link\]](#)
- Synthesis of 2-Substituted Pyridines via a Regiospecific Alkylation, Alkynylation, and Arylation of Pyridine N-Oxides. Organic Chemistry Portal. Available at: [\[Link\]](#)
- A Mild and Highly Diastereoselective Preparation of N-Alkenyl-2-Pyridones via 2-Halopyridinium Salts and Aldehydes. PMC. Available at: [\[Link\]](#)
- Regioselective synthesis of 2-(2-hydroxyaryl)pyridines from the reactions of benzyne with pyridine N-oxides. RSC Publishing. Available at: [\[Link\]](#)
- Regiodivergent Alkylation of Pyridines: Alkylolithium Clusters Direct Chemical Reactivity. American Chemical Society. Available at: [\[Link\]](#)
- Alkylation and acylation of pyridine. quimicaorganica.org. Available at: [\[Link\]](#)
- Optimization of 2-pyridone ligands and transient directing groups. ResearchGate. Available at: [\[Link\]](#)
- NEW FUNCTIONALISATION CHEMISTRY OF 2- AND 4-PYRIDONES AND RELATED HETEROCYCLES. Loughborough University Research Repository. Available at: [\[Link\]](#)
- Efficient Synthesis of Novel Pyridine-Based Derivatives via Suzuki Cross-Coupling Reaction of Commercially Available 5-Bromo-2-methylpyridin-3-amine: Quantum Mechanical Investigations and Biological Activities. MDPI. Available at: [\[Link\]](#)

- Pyridine Nucleus as a Directing Group for Metal-Based C-H Bond Activation. ResearchGate. Available at: [\[Link\]](#)
- Directing Group-Free Regioselective meta-C-H Functionalization of Pyridines. PubMed. Available at: [\[Link\]](#)
- Recent Progress in Nitro-Promoted Direct Functionalization of Pyridones and Quinolones. PMC. Available at: [\[Link\]](#)
- P(NMe₂)₃-Mediated Regioselective N-Alkylation of 2-Pyridones via Direct Deoxygenation of α -Keto Esters. Organic Chemistry Portal. Available at: [\[Link\]](#)
- A lesson for site-selective C–H functionalization on 2-pyridones: radical, organometallic, directing group and steric controls. Chemical Science (RSC Publishing). Available at: [\[Link\]](#)
- Mechanism and regioselectivity in an open-and-shut case of pyridine halogenation. academictree.org. Available at: [\[Link\]](#)
- Removal of the Pyridine Directing Group from α -Substituted N-(Pyridin-2-yl)piperidines Obtained via Directed Ru-Catalyzed sp³ C–H Functionalization. ResearchGate. Available at: [\[Link\]](#)
- Regioselectivity of pyridine nucleus. ResearchGate. Available at: [\[Link\]](#)
- PALLADIUM-CATALYZED CROSS COUPLINGS IN ORGANIC SYNTHESIS. Nobel Prize. Available at: [\[Link\]](#)
- Selective C-H Functionalization. Organic Chemistry Portal. Available at: [\[Link\]](#)
- Why n-alkylation is more favorable than o-alkylation? ResearchGate. Available at: [\[Link\]](#)
- A lesson for site-selective C–H functionalization on 2-pyridones: radical, organometallic, directing group and steric controls. PMC. Available at: [\[Link\]](#)
- Site-Selective Aliphatic C-H Bromination Using N-Bromoamides and Visible Light. pubs.acs.org. Available at: [\[Link\]](#)

- Regioselective reactions of 3,4-pyridynes enabled by the aryne distortion model. PubMed. Available at: [\[Link\]](#)
- meta-Selective C-H Functionalization of Pyridines. PubMed. Available at: [\[Link\]](#)
- Regioselective C-H Functionalization of the Six-Membered Ring of the 6,5-Fused Heterocyclic Systems: An Overview. MDPI. Available at: [\[Link\]](#)
- Advances in the site-selective C-5, C-3 and C-2 functionalization of chromones via sp² C–H activation. RSC Publishing. Available at: [\[Link\]](#)
- Palladium Catalyzed Cross-Coupling of Five-Membered Heterocyclic Silanolates. PMC. Available at: [\[Link\]](#)
- The ubiquitous cross-coupling catalyst system 'Pd(OAc)₂/2PPh₃ forms a unique dinuclear PdI complex: an important entry point into catalytically competent cyclic Pd₃ clusters. Chemical Science (RSC Publishing). Available at: [\[Link\]](#)
- Regioselectivity – Knowledge and References. Taylor & Francis. Available at: [\[Link\]](#)
- one-pot synthesis of n-alkylated 2-pyridone derivatives under microwave irradiation. Sciforum. Available at: [\[Link\]](#)
- Pd-Catalyzed Cross-Couplings: On the Importance of the Catalyst Quantity Descriptors, mol % and ppm. ACS Publications. Available at: [\[Link\]](#)
- N- versus O-alkylation: utilizing NMR methods to establish reliable primary structure determinations for drug discovery. PubMed. Available at: [\[Link\]](#)
- Mild and Regioselective N-Alkylation of 2-Pyridones in Water. ResearchGate. Available at: [\[Link\]](#)
- N-Alkylation of Some Imidazopyridines. FABAD Journal of Pharmaceutical Sciences. Available at: [\[Link\]](#)
- 2-Bromopyridines as Versatile Synthons for Heteroarylated 2-Pyridones via Ru(II)-Mediated Domino C–O/C–N/C–C Bond Formation Reactions. PMC. Available at: [\[Link\]](#)

- Regioselective synthesis of 3-alkynyl-5-bromo-2-pyrones via Pd-catalyzed couplings on 3,5-dibromo-2-pyrone. PubMed. Available at: [\[Link\]](#)
- Regioselective difunctionalization of pyridines via 3,4-pyridynes. RSC Publishing. Available at: [\[Link\]](#)

Need Custom Synthesis?

BenchChem offers custom synthesis for rare earth carbides and specific isotopic labeling.

Email: info@benchchem.com or [Request Quote Online](#).

Sources

- 1. A lesson for site-selective C–H functionalization on 2-pyridones: radical, organometallic, directing group and steric controls - Chemical Science (RSC Publishing) DOI:10.1039/C7SC04509C [pubs.rsc.org]
- 2. A lesson for site-selective C–H functionalization on 2-pyridones: radical, organometallic, directing group and steric controls - PMC [pubmed.ncbi.nlm.nih.gov]
- 3. P(NMe₂)₃-Mediated Regioselective N-Alkylation of 2-Pyridones via Direct Deoxygenation of α-Keto Esters [[organic-chemistry.org](https://www.organic-chemistry.org)]
- 4. [mdpi.com](https://www.mdpi.com) [[mdpi.com](https://www.mdpi.com)]
- 5. A Mild and Highly Diastereoselective Preparation of N-Alkenyl-2-Pyridones via 2-Halopyridinium Salts and Aldehydes - PMC [pubmed.ncbi.nlm.nih.gov]
- 6. Sciforum : Event management platform [[sciforum.net](https://www.sciforum.net)]
- 7. [researchgate.net](https://www.researchgate.net) [[researchgate.net](https://www.researchgate.net)]
- 8. N- versus O-alkylation: utilizing NMR methods to establish reliable primary structure determinations for drug discovery - PubMed [pubmed.ncbi.nlm.nih.gov]
- 9. [researchgate.net](https://www.researchgate.net) [[researchgate.net](https://www.researchgate.net)]
- 10. [dergi.fabad.org.tr](https://www.dergi.fabad.org.tr) [[dergi.fabad.org.tr](https://www.dergi.fabad.org.tr)]
- 11. [nobelprize.org](https://www.nobelprize.org) [[nobelprize.org](https://www.nobelprize.org)]
- 12. Regioselective synthesis of 3-alkynyl-5-bromo-2-pyrones via Pd-catalyzed couplings on 3,5-dibromo-2-pyrone - PubMed [pubmed.ncbi.nlm.nih.gov]
- 13. pdf.benchchem.com [pdf.benchchem.com]

- [14. pdf.benchchem.com \[pdf.benchchem.com\]](https://pdf.benchchem.com)
- [15. The ubiquitous cross-coupling catalyst system 'Pd\(OAc\)₂/2PPh₃ forms a unique dinuclear PdI complex: an important entry point into catalytically competent cyclic Pd₃ clusters - Chemical Science \(RSC Publishing\) \[pubs.rsc.org\]](#)
- [16. pubs.acs.org \[pubs.acs.org\]](https://pubs.acs.org)
- [17. researchgate.net \[researchgate.net\]](https://researchgate.net)
- [18. researchgate.net \[researchgate.net\]](https://researchgate.net)
- [19. researchgate.net \[researchgate.net\]](https://researchgate.net)
- To cite this document: BenchChem. [Technical Support Center: Controlling Regioselectivity in 5-Bromo-Pyridin-2-one Functionalization]. BenchChem, [2026]. [Online PDF]. Available at: [\[https://www.benchchem.com/product/b2534667/docs#technical-support-center-controlling-regioselectivity-in-5-bromo-pyridin-2-one-functionalization\]](https://www.benchchem.com/product/b2534667/docs#technical-support-center-controlling-regioselectivity-in-5-bromo-pyridin-2-one-functionalization)

Disclaimer & Data Validity:

The information provided in this document is for Research Use Only (RUO) and is strictly not intended for diagnostic or therapeutic procedures. While BenchChem strives to provide accurate protocols, we make no warranties, express or implied, regarding the fitness of this product for every specific experimental setup.

Technical Support: The protocols provided are for reference purposes. Unsure if this reagent suits your experiment?

Need Industrial/Bulk Grade? [Request Custom Synthesis Quote](#)

BenchChem

Our mission is to be the trusted global source of essential and advanced chemicals, empowering scientists and researchers to drive progress in science and industry.

Contact

Address: 3281 E Guasti Rd
Ontario, CA 91761, United States
Phone: (601) 213-4426
Email: info@benchchem.com

Contact our Ph.D. Support Team for a compatibility check