

Technical Support Center: High-Efficiency Coupling of Methyl 2-(3-iodophenyl)acetate

Author: BenchChem Technical Support Team. **Date:** May 2026

Compound of Interest

Compound Name: Methyl 2-(3-iodophenyl)acetate

CAS No.: 502649-73-2

Cat. No.: B2530432

[Get Quote](#)

Ticket ID: OPT-53093-65-5 Status: Open Assigned Specialist: Senior Application Scientist, Process Optimization Unit[1]

Executive Summary & Chemical Profile

Subject: **Methyl 2-(3-iodophenyl)acetate** (CAS: 53093-65-5) Core Challenge: Optimizing reaction kinetics (turnover frequency) while preserving the base-sensitive methyl ester functionality during Palladium-catalyzed cross-coupling (Suzuki-Miyaura, Sonogashira, Heck).

Technical Assessment: **Methyl 2-(3-iodophenyl)acetate** presents a classic "Reactivity vs. Stability" paradox.[1] The aryl iodide moiety (C-I bond) allows for rapid oxidative addition, theoretically enabling fast reaction times. However, the pendant methyl ester is susceptible to hydrolysis (saponification) under the aqueous basic conditions typical of standard Suzuki protocols. Furthermore, the high reactivity of the iodide can lead to homocoupling (Ullmann-type side reactions) if the catalytic cycle is not properly balanced.

This guide provides an optimized workflow to reduce reaction times from hours (thermal) to minutes (microwave/high-activity catalyst) while maintaining >95% chemoselectivity for the

ester.

Critical Parameter Optimization (The "Engine")

To improve efficiency, we must upgrade the catalytic "engine" from first-generation systems (e.g., Pd(PPh₃)₄) to third-generation precatalysts.

A. Catalyst & Ligand Selection

Standard Pd(PPh₃)₄ is often too slow and air-sensitive.[1] For this substrate, we recommend bulky, electron-rich phosphine ligands or NHC complexes.[1]

Parameter	Standard (Legacy)	Optimized (High Efficiency)	Technical Rationale
Catalyst	Pd(PPh ₃) ₄	XPhos Pd G4 or Pd(dppf)Cl ₂	G4 precatalysts ensure rapid activation at low temperatures; dppf prevents dehalogenation.[1]
Ligand	Triphenylphosphine	XPhos or SPhos	Bulky biaryl ligands accelerate reductive elimination, the rate-determining step for sterically demanding couplings.[1]
Loading	5–10 mol%	0.5–2.0 mol%	High-activity ligands increase Turnover Number (TON), reducing cost and metal scavenging needs.[1]

B. Reaction Environment (The "Fuel")

The choice of base and solvent is critical to preventing the "Ester Trap" (hydrolysis).[2]

Component	Standard (Risk)	Optimized (Safe)	Mechanism of Improvement
Base	NaOH, KOH, NaOEt	K ₃ PO ₄ or Cs ₂ CO ₃	Weaker, non-nucleophilic bases minimize attack on the methyl ester carbonyl. [1]
Solvent	MeOH/Water	Dioxane/Water (10:1) or Toluene	Reducing water content and avoiding primary alcohols prevents transesterification and hydrolysis.[1]
Energy	Thermal (Reflux)	Microwave (80–100°C)	Microwave irradiation provides volumetric heating, reducing reaction time from 12h to <20 min.

Visualizing the Optimization Logic

The following diagram illustrates the decision matrix for optimizing the coupling of **Methyl 2-(3-iodophenyl)acetate**, highlighting the pathways to avoid side reactions.

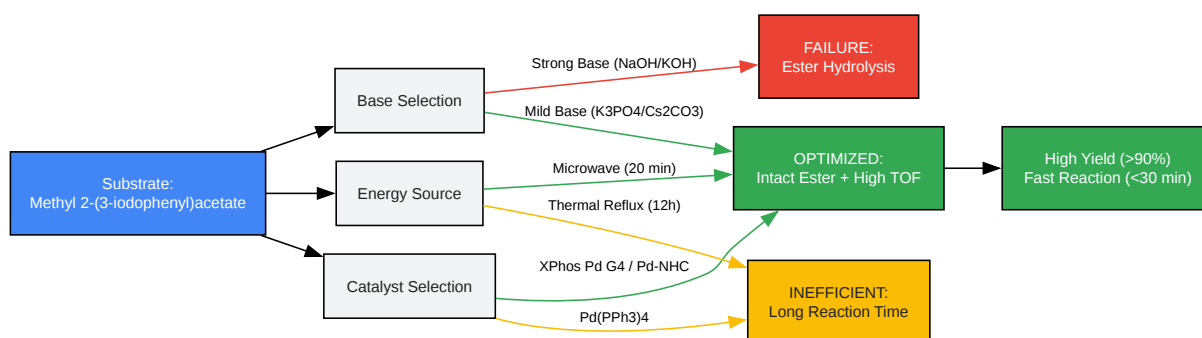

[Click to download full resolution via product page](#)

Figure 1: Optimization logic flow. Green paths indicate the recommended protocol to avoid hydrolysis and slow kinetics.

Troubleshooting Specific Failures (FAQs)

Q1: I am observing the formation of (3-iodophenyl)acetic acid instead of the coupled product. What is happening?

- **Diagnosis:** Saponification.^[1] You are likely using a hydroxide base (NaOH) or running the reaction in a solvent mixture with too much water/alcohol at high temperatures.
- **Fix:** Switch to anhydrous conditions using Cesium Carbonate (Cs₂CO₃) in Toluene or Dioxane.^[1] If water is required for boronic acid solubility, limit it to a 10:1 ratio and use Potassium Phosphate (K₃PO₄) as the base.

Q2: The reaction stalls at 60% conversion despite using 10 mol% Pd(PPh₃)₄.

- **Diagnosis:** Catalyst deactivation (Pd black formation) or oxidation of the phosphine ligand. Aryl iodides release iodide ions, which can poison Pd catalysts in the absence of stabilizing ligands.

- Fix: Switch to Pd(dppf)Cl₂ or XPhos Pd G3.[1] These ligands bind tighter to the metal center, extending the catalyst lifetime. Alternatively, add a "catalyst booster" like TBAB (Tetrabutylammonium bromide) to stabilize the Pd nanoparticles.

Q3: I see a significant amount of homocoupling (dimerization of the starting material).

- Diagnosis: This is common with aryl iodides.[1] It is often caused by the presence of oxygen or excessive catalyst loading.
- Fix:
 - Degas rigorously: Sparge solvents with Argon for 15 minutes before adding the catalyst.
 - Slow Addition: Add the aryl iodide slowly to the mixture if possible (though less practical in microwave).
 - Change Solvent: Switch from DMF to Toluene/Water mixtures; homocoupling is often favored in polar aprotic solvents.[1]

Optimized Experimental Protocol

Method: Microwave-Assisted Suzuki-Miyaura Coupling Target Scale: 1.0 mmol[1]

Materials

- **Methyl 2-(3-iodophenyl)acetate** (1.0 equiv)[1]
- Aryl Boronic Acid (1.2 – 1.5 equiv)
- Catalyst: XPhos Pd G4 (2 mol%) or Pd(dppf)Cl₂ (3 mol%)
- Base: K₃PO₄ (2.0 equiv)
- Solvent: 1,4-Dioxane : Water (9:1 ratio)[1]

Workflow

- Charge Vessel: In a microwave-safe vial, add the **methyl 2-(3-iodophenyl)acetate**, boronic acid, and K₃PO₄.

- Solvent Addition: Add the Dioxane/Water mixture.[1]
- Degas: Cap the vial and purge with Argon/Nitrogen for 5 minutes (via needle).
- Catalyst Addition: Remove the cap briefly (under inert flow) to add the Pd catalyst, then recap immediately.
- Reaction: Irradiate in a microwave reactor:
 - Temperature: 100 °C
 - Time: 20 minutes
 - Stirring: High
- Workup: Dilute with Ethyl Acetate, wash with water (x2) and brine. Dry over MgSO₄. [1]
- Purification: Flash chromatography (Hexane/EtOAc).

Troubleshooting Flowchart

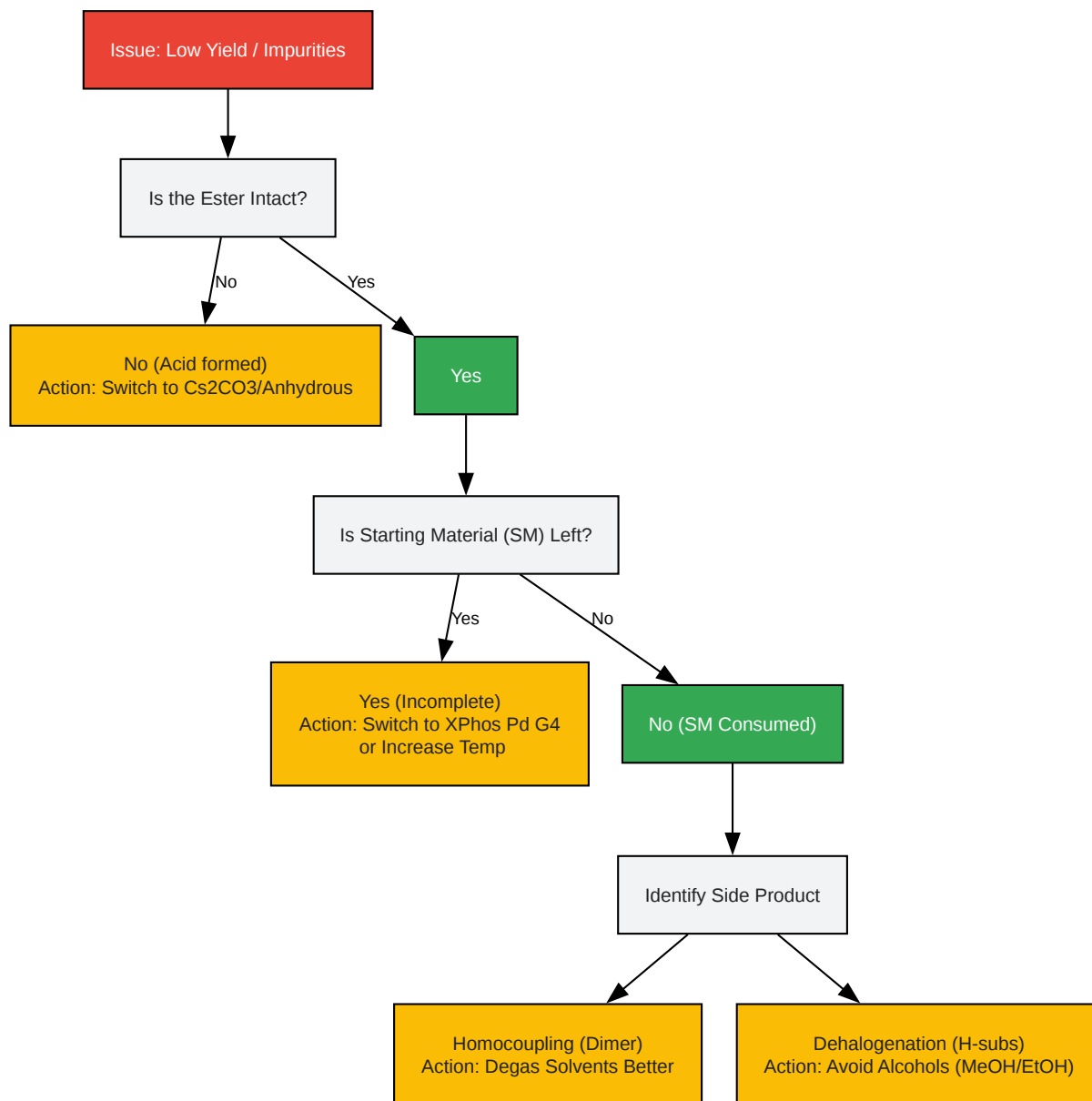

[Click to download full resolution via product page](#)

Figure 2: Diagnostic workflow for resolving reaction failures.

References

- National Center for Biotechnology Information (2025). PubChem Compound Summary for CID 21939462, **Methyl 2-(3-iodophenyl)acetate**.^[1] Retrieved from [\[Link\]](#)
- Miyaura, N., & Suzuki, A. (1995). Palladium-Catalyzed Cross-Coupling Reactions of Organoboron Compounds.^[1] *Chemical Reviews*, 95(7), 2457-2483. (Foundational text on mechanism and base selection).
- Martin, R., & Buchwald, S. L. (2008). Palladium-Catalyzed Suzuki-Miyaura Cross-Coupling Reactions Employing Dialkylbiaryl Phosphine Ligands.^[1] *Accounts of Chemical Research*, 41(11), 1461–1473. (Source for XPhos/SPhos efficiency).
- Kappe, C. O. (2004). Controlled Microwave Heating in Modern Organic Synthesis.^[1] *Angewandte Chemie International Edition*, 43(46), 6250-6284. (Source for microwave kinetic acceleration).^{[3][4]}
- Sigma-Aldrich. Product Specification: Methyl (3-iodophenyl)acetate (CAS 53093-65-5).^[1] (Verification of CAS/Structure identity).

Need Custom Synthesis?

BenchChem offers custom synthesis for rare earth carbides and specific isotopic labeling.

Email: info@benchchem.com or [Request Quote Online](#).

Sources

- 1. CN101225045A - Micro-wave synthetic method for preparing methyl salicylate - Google Patents [\[patents.google.com\]](https://patents.google.com)
- 2. Elucidating the Role of the Boronic Esters in the Suzuki–Miyaura Reaction: Structural, Kinetic, and Computational Investigations - PMC [\[pmc.ncbi.nlm.nih.gov\]](https://pubmed.ncbi.nlm.nih.gov)
- 3. [researchgate.net](https://www.researchgate.net) [\[researchgate.net\]](https://www.researchgate.net)
- 4. [chemicaljournals.com](https://www.chemicaljournals.com) [\[chemicaljournals.com\]](https://www.chemicaljournals.com)
- To cite this document: BenchChem. [Technical Support Center: High-Efficiency Coupling of Methyl 2-(3-iodophenyl)acetate]. BenchChem, [2026]. [Online PDF]. Available at:

[<https://www.benchchem.com/product/b2530432/docs#technical-support-center-high-efficiency-coupling-of-methyl-2-3-iodophenyl-acetate>]

Disclaimer & Data Validity:

The information provided in this document is for Research Use Only (RUO) and is strictly not intended for diagnostic or therapeutic procedures. While BenchChem strives to provide accurate protocols, we make no warranties, express or implied, regarding the fitness of this product for every specific experimental setup.

Technical Support: The protocols provided are for reference purposes. Unsure if this reagent suits your experiment?

Need Industrial/Bulk Grade? [Request Custom Synthesis Quote](#)

BenchChem

Our mission is to be the trusted global source of essential and advanced chemicals, empowering scientists and researchers to drive progress in science and industry.

Contact

Address: 3281 E Guasti Rd
Ontario, CA 91761, United States
Phone: (601) 213-4426
Email: info@benchchem.com

[Contact our Ph.D. Support Team for a compatibility check](#)