

Biological activity of peptides containing D-alanine

Author: BenchChem Technical Support Team. **Date:** May 2026

Compound of Interest

Compound Name: N-Cbz-d-alanine
CAS No.: 1142-20-7; 26607-51-2
Cat. No.: B2529757

[Get Quote](#)

An In-Depth Technical Guide to the Biological Activity of Peptides Containing D-Alanine

Prepared by: Gemini, Senior Application Scientist

Abstract

The incorporation of non-proteinogenic amino acids into peptides represents a cornerstone of modern drug discovery and chemical biology. Among these, D-amino acids, the enantiomeric counterparts to the canonical L-amino acids, have garnered significant attention. This guide provides a comprehensive technical overview of the biological impact of incorporating D-alanine into peptide sequences. We will explore the fundamental stereochemical principles that govern the unique properties of D-alanine-containing peptides, from their profound effects on secondary structure and conformational stability to their remarkable resistance to enzymatic degradation. This guide delves into the natural roles of D-alanine in bacterial cell wall biosynthesis and neuromodulation, and critically examines its strategic application in the design of robust therapeutic peptides, including next-generation antimicrobial agents and drug candidates with enhanced pharmacokinetic profiles. Methodological insights, including detailed protocols for synthesis and analysis, are provided to equip researchers and drug development

professionals with the practical knowledge required to harness the therapeutic potential of D-alanine modification.

Introduction: The Chirality of Life and the Significance of D-Amino Acids

In the central dogma of molecular biology, proteins and peptides are constructed almost exclusively from L-amino acids. This homochirality is a fundamental characteristic of life, with the ribosomal machinery specifically evolved to recognize and incorporate L-isomers.[1] However, a fascinating world of D-amino acids exists beyond this canonical framework, playing critical roles in various biological systems. D-amino acids are found in organisms ranging from bacteria to humans, where they function in cell wall structure, signaling, and defense.[2][3]

The substitution of a single L-amino acid with its D-enantiomer can dramatically alter a peptide's three-dimensional structure and, consequently, its biological activity. This simple chiral inversion—from (S)-configuration in L-alanine to (R)-configuration in D-alanine—introduces profound changes in backbone torsion angles and side-chain orientations. These structural perturbations are the primary drivers of the unique biological properties conferred by D-alanine, most notably a dramatic increase in resistance to proteolysis.[1][4] This guide will dissect the science behind these properties and illustrate how the strategic incorporation of D-alanine has become an indispensable tool in peptide science and therapeutic development.

The Stereochemical Keystone: How D-Alanine Shapes Peptide Structure and Function

The substitution of an L-alanine with a D-alanine residue imposes significant local conformational constraints on the peptide backbone. While L-amino acids preferentially adopt conformations like the right-handed α -helix or standard β -sheets, the introduction of a D-amino acid disrupts these structures and favors alternative arrangements.[5][6]

Induction of Secondary Structures

The presence of a D-alanine residue can induce specific types of turns, such as β -turns, in the peptide backbone.[5] This is a direct consequence of the altered stereochemistry, which favors backbone dihedral angles (ϕ , ψ) that are energetically unfavorable for L-amino acids in the same position. Theoretical and experimental studies have shown that D-alanine can stabilize

unique helical structures or induce kinks in otherwise linear peptides.[7][8] This ability to precisely control peptide conformation is a powerful tool for designing peptides that fit into specific receptor binding pockets or adopt bioactive conformations.

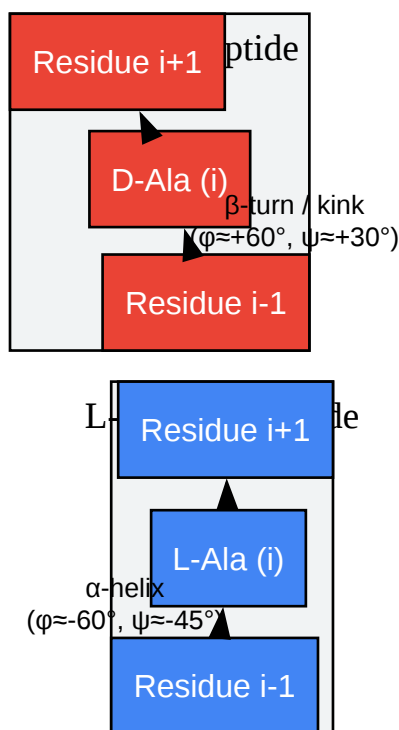

[Click to download full resolution via product page](#)

Caption: Impact of D-Alanine on Peptide Backbone Conformation.

Impact on Conformational Flexibility

Compared to glycine, which lacks a side chain and thus has high conformational flexibility, both L- and D-alanine restrict the available conformational space due to the presence of the methyl side chain.[9] However, the specific regions of the Ramachandran plot that are favored differ significantly between the L- and D-isomers. The incorporation of D-alanine can therefore be used to "lock" a peptide into a more rigid and defined conformation, reducing the entropic penalty upon binding to a target and potentially increasing binding affinity.

The Shield of Stability: D-Alanine as a Potent Tool for Enhancing Proteolytic Resistance

One of the most significant and therapeutically valuable consequences of incorporating D-alanine into a peptide is the profound increase in its stability against enzymatic degradation.[1] [4] Peptidases and proteases, the enzymes responsible for peptide breakdown, exhibit a high degree of stereospecificity, having evolved to recognize and cleave peptide bonds flanked by L-amino acids.

The Mechanics of Protease Evasion

The active site of a protease is a precisely shaped pocket that accommodates the substrate peptide in a specific orientation. The substitution of an L-amino acid with a D-amino acid creates a stereochemical clash that prevents the peptide from binding correctly within the enzyme's active site. This steric hindrance effectively renders the adjacent peptide bonds resistant to cleavage. This principle is a cornerstone of modern peptide drug design, as it directly addresses the primary limitation of peptide therapeutics: their short in vivo half-life.[10]

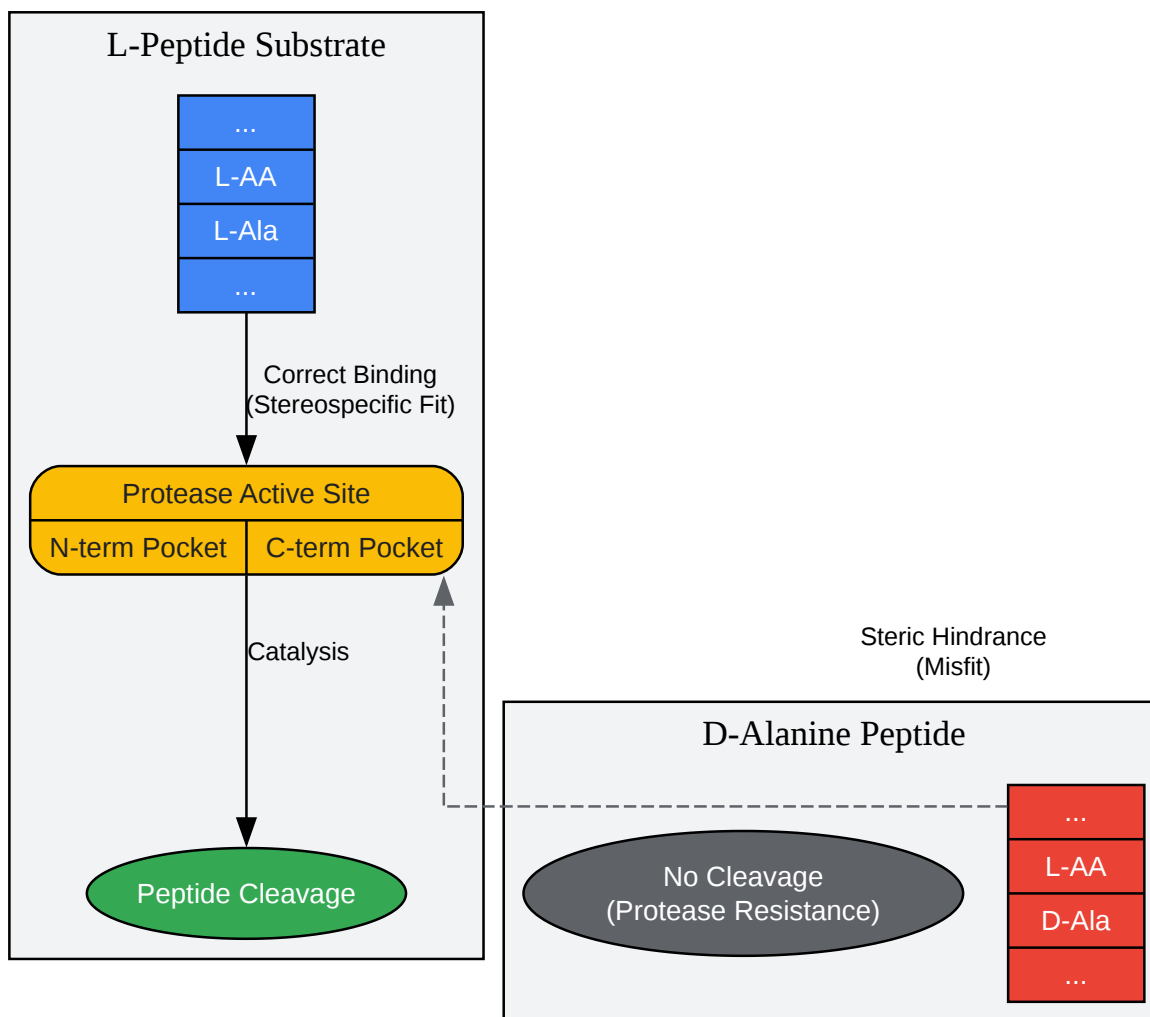

[Click to download full resolution via product page](#)

Caption: Mechanism of D-Alanine-Mediated Protease Resistance.

D-Alanine in Nature's Blueprint

While engineered by scientists for therapeutic advantage, D-alanine is no mere laboratory curiosity. Nature has long employed this non-canonical amino acid for critical biological functions.

The Bacterial Fortress: D-Alanine in Peptidoglycan and Teichoic Acids

D-alanine is an indispensable component of the bacterial cell wall.[11][12][13] The structural integrity of peptidoglycan, the mesh-like layer that protects bacteria from osmotic stress, relies on cross-links formed between peptide stems. These stems universally feature a terminal D-alanyl-D-alanine (D-Ala-D-Ala) dipeptide.[3][14][15] The synthesis of this dipeptide is catalyzed by the D-alanine-D-alanine ligase (Ddl) enzyme, a critical target for antibiotics.[15] The final transpeptidation reaction, which creates the peptidoglycan cross-links, involves the cleavage of the terminal D-alanine.[14] This entire process is a primary target for iconic antibiotics like penicillin and vancomycin.[14]

Furthermore, D-alanine is used to modify teichoic acids, which are polymers on the surface of Gram-positive bacteria.[16][17] This D-alanylation reduces the net negative charge of the bacterial cell surface, which in turn decreases susceptibility to positively charged cationic antimicrobial peptides (AMPs) produced by the host immune system.[11][18][13][16][17][19]

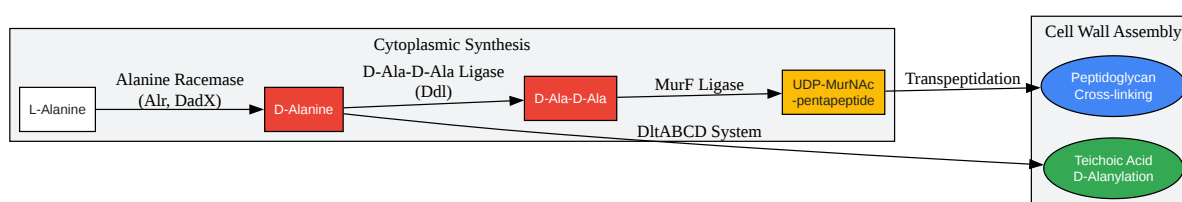

[Click to download full resolution via product page](#)

Caption: Role of D-Alanine in Bacterial Cell Wall Synthesis.

Neuromodulation and Beyond: D-Alanine in Neuropeptides and Toxins

Beyond the microbial world, D-amino acids are found in the neuropeptides and toxins of various animals, including mollusks, amphibians, and spiders.[20] The isomerization of an L-amino acid to its D-enantiomer is a post-translational modification that can dramatically alter the peptide's interaction with its receptor.[21][22] For instance, the opioid peptide dermorphin,

originally isolated from frog skin, contains a D-alanine at the second position, which is crucial for its high potency and selectivity for the μ -opioid receptor.[22] This modification is catalyzed by a specific L-to-D amino acid isomerase.[22] The presence of D-alanine in these neuropeptides suggests a sophisticated evolutionary strategy to fine-tune signaling pathways and enhance peptide stability.[2][20]

Engineering Peptide Therapeutics with D-Alanine

The insights gained from nature's use of D-alanine, combined with its profound impact on stability, have made it a premier tool for peptide drug development.

Revitalizing Antimicrobial Peptides (AMPs)

AMPs are a promising class of therapeutics for combating antibiotic-resistant bacteria.[23] However, their clinical utility is often hampered by their susceptibility to host and bacterial proteases. Substituting specific L-amino acids with D-alanine is a well-established strategy to overcome this limitation.[4][10] This modification can significantly enhance the peptide's stability in biological fluids like serum, leading to improved antimicrobial activity and a longer duration of action, without necessarily compromising the membrane-disrupting mechanism of action.[4]

Table 1: Impact of D-Amino Acid Substitution on Antimicrobial Peptide (AMP) Stability

Peptide	Sequence	Modification	Half-life in Serum ($t_{1/2}$)	Reference MIC ($\mu\text{g/mL}$)
R4F4	(L-Arg) ₄ -(L-Phe) ₄	All L-amino acids	< 30 min	8
D-R4F4	(D-Arg) ₄ -(D-Phe) ₄	All D-amino acids	> 24 hours	4

Data conceptualized from findings in reference[4]. MIC (Minimum Inhibitory Concentration) is a representative value against a common bacterial strain.

Optimizing Peptide Drugs for Enhanced Pharmacokinetics

For any peptide drug candidate, achieving a favorable pharmacokinetic profile is essential. The strategic placement of D-alanine can extend the circulating half-life of a peptide by protecting it from degradation by systemic proteases. This leads to reduced dosing frequency and improved patient compliance. This approach has been successfully applied to numerous peptide hormones and their analogs, transforming peptides with fleeting in vivo action into viable therapeutic agents.

Methodologies in D-Alanine Peptide Research

Harnessing the power of D-alanine requires robust methodologies for both the synthesis of modified peptides and the validation of their properties.

Synthesis of D-Alanine-Containing Peptides

The most common method for producing D-alanine-containing peptides is solid-phase peptide synthesis (SPPS). This technique involves the stepwise addition of amino acids to a growing peptide chain anchored to a solid resin support. To incorporate D-alanine, a protected D-alanine building block, such as Fmoc-D-Ala-OH or Boc-D-Ala-OH, is used in the appropriate cycle of the synthesis. A particularly useful building block is H-D-Ala-OtBu·HCl, which is designed for efficient incorporation within the Fmoc/tBu synthesis framework.[\[24\]](#)

Alternatively, enzymatic methods are emerging for the post-translational introduction of D-alanine into ribosomally synthesized peptides.[\[1\]](#) For instance, enzymes involved in lanthipeptide biosynthesis can be engineered to catalyze the formation of D-alanine from dehydroalanine residues, which are themselves derived from serine.[\[1\]](#)

Protocol: Solid-Phase Synthesis of a D-Alanine-Modified Peptide

Objective: To synthesize a peptide with a D-alanine substitution using Fmoc/tBu solid-phase chemistry.

Causality: The Fmoc protecting group on the α -amine is base-labile, allowing for its selective removal without affecting the acid-labile side-chain protecting groups or the resin linkage. The

D-alanine is introduced as a standard building block at the desired position in the sequence.

Materials:

- Fmoc-Rink Amide resin
- Fmoc-L-amino acids with acid-labile side-chain protection (e.g., Trt, Boc, tBu)
- Fmoc-D-Ala-OH
- Coupling reagents: HBTU, HOBt
- Activator base: DIPEA
- Deprotection solution: 20% piperidine in DMF
- Solvents: DMF, DCM
- Cleavage cocktail: Reagent B (88% TFA, 5% Phenol, 5% Water, 2% TIS)[\[24\]](#)
- Cold diethyl ether

Procedure:

- Resin Swelling: Swell the Fmoc-Rink Amide resin in DMF for 30 minutes.
- Fmoc Deprotection: Remove the Fmoc group from the resin by treating with 20% piperidine in DMF for 5 minutes, then again for 15 minutes. Wash thoroughly with DMF.
- Amino Acid Coupling: a. Pre-activate the first Fmoc-L-amino acid (3 eq.) with HBTU (3 eq.), HOBt (3 eq.), and DIPEA (6 eq.) in DMF for 5 minutes. b. Add the activated amino acid solution to the deprotected resin and shake for 1-2 hours. c. Monitor coupling completion with a Kaiser test.
- Chain Elongation: Repeat steps 2 and 3 for each amino acid in the sequence. For the desired position, use Fmoc-D-Ala-OH in the coupling step.

- Final Deprotection: After the final amino acid is coupled, perform a final Fmoc deprotection (Step 2).
- Cleavage and Global Deprotection: a. Wash the peptide-resin with DCM and dry under vacuum. b. Treat the resin with the cleavage cocktail for 2-3 hours at room temperature.^[24] c. Filter the resin and collect the TFA solution containing the peptide.
- Peptide Precipitation: Precipitate the crude peptide by adding the TFA solution to a large volume of cold diethyl ether.^[24]
- Purification: Pellet the peptide by centrifugation, wash with cold ether, and dry. Purify the crude peptide using reverse-phase HPLC.
- Verification: Confirm the mass and purity of the final peptide using LC-MS.

Protocol: Assessing Proteolytic Stability of Peptides

Objective: To compare the stability of an L-peptide and its D-alanine-containing analog in the presence of a protease.

Self-Validation: This protocol includes a positive control (the all-L peptide, which should be degraded) and the test article (the D-Ala peptide). The stability is quantified by measuring the disappearance of the full-length peptide peak over time via HPLC, providing a direct and robust measure of degradation.

Materials:

- Purified L-peptide and D-Ala-peptide
- Protease solution (e.g., Trypsin, Chymotrypsin, or Human Serum)
- Reaction buffer (e.g., PBS, pH 7.4)
- Quenching solution (e.g., 10% TFA)
- RP-HPLC system with a C18 column

Procedure:

- Prepare Peptide Stocks: Dissolve both peptides in the reaction buffer to a final concentration of 1 mg/mL.
- Reaction Setup: a. In separate microcentrifuge tubes, mix 90 μ L of each peptide stock with 10 μ L of the protease solution (e.g., 10% human serum). b. For a T=0 time point, immediately quench 10 μ L of the reaction mixture with 90 μ L of 10% TFA.
- Incubation: Incubate the reaction tubes at 37°C.
- Time Points: At various time points (e.g., 1, 4, 8, 24 hours), withdraw 10 μ L of the reaction mixture and quench it in 90 μ L of 10% TFA.
- HPLC Analysis: a. Analyze each quenched time point sample by RP-HPLC. b. Use a gradient of water/acetonitrile (both containing 0.1% TFA). c. Monitor the absorbance at 214 nm or 280 nm.
- Data Analysis: a. Integrate the peak area of the full-length peptide at each time point. b. Normalize the peak area at each time point to the T=0 peak area. c. Plot the percentage of remaining peptide versus time for both the L-peptide and the D-Ala-peptide to determine their respective half-lives.

Protocol: Confirming D-Amino Acid Incorporation

Objective: To verify the presence and position of a D-amino acid in a synthetic peptide.

Causality: This method leverages the stereospecificity of certain enzymes. For example, microsomal alanyl aminopeptidase selectively cleaves peptides from the N-terminus but will stop if it encounters a D-amino acid at the second position.^[21] Comparing the mass spectrometry (MS) fragmentation patterns before and after enzymatic digestion can pinpoint the location of the D-amino acid.

Materials:

- Purified peptide of unknown or to-be-confirmed chirality
- Chirally selective enzyme (e.g., microsomal alanyl aminopeptidase)
- Digestion buffer

- Mass spectrometer (e.g., MALDI-TOF or ESI-MS)

Procedure:

- Initial MS Analysis: Obtain a high-resolution mass spectrum of the intact peptide to confirm its molecular weight.
- Enzymatic Digestion: a. Dissolve the peptide in the appropriate digestion buffer. b. Add the chirally selective aminopeptidase. c. Incubate under optimal conditions (e.g., 37°C for 1-4 hours).
- Post-Digestion MS Analysis: a. Analyze the digestion mixture using mass spectrometry. b. Interpretation:
 - If the peptide contains an L-amino acid at position 2, it will be degraded, and the full-length peptide peak will disappear or be significantly reduced.
 - If the peptide contains a D-amino acid at position 2, the enzyme will be blocked, and the full-length peptide peak will remain unchanged.[\[21\]](#)
- Confirmation: Comparison of the "before" and "after" spectra provides strong evidence for the presence of a D-amino acid at the specific position targeted by the enzyme.

Conclusion and Future Perspectives

The incorporation of D-alanine is more than a simple chemical trick; it is a sophisticated, bio-inspired strategy for manipulating the structure, stability, and function of peptides. From its fundamental role in defining bacterial architecture to its application in creating next-generation therapeutics, D-alanine offers a powerful solution to the inherent limitations of canonical peptides. As our understanding of peptide-protein interactions deepens and new enzymatic tools for peptide modification become available, the rational design of D-alanine-containing peptides will continue to be a driving force in drug discovery, enabling the development of more potent, stable, and effective peptide-based medicines. The continued exploration of D-amino acid isomerases and their substrate specificities may one day allow for the programmable, in vivo production of D-amino acid-containing peptides, opening new frontiers in synthetic biology and medicine.

References

- Ushijima, Y., et al. (2025). D-alanine synthesis and exogenous alanine affect the antimicrobial susceptibility of Staphylococcus aureus. ASM Journals. [[Link](#)]
- Ushijima, Y., et al. (2025). D-alanine synthesis and exogenous alanine affect the antimicrobial susceptibility of Staphylococcus aureus. PMC - NIH. [[Link](#)]
- Ushijima, Y., et al. (2025). (PDF) D-alanine synthesis and exogenous alanine affect the antimicrobial susceptibility of Staphylococcus aureus. ResearchGate. [[Link](#)]
- Ushijima, Y., et al. (2025). D-alanine synthesis and exogenous alanine affect the antimicrobial susceptibility of Staphylococcus aureus. PubMed. [[Link](#)]
- Bhatnagar, S., Rao, G. S., & Singh, T. P. (1995). The role of dehydro-alanine in the design of peptides. Biosystems. [[Link](#)]
- Montalbán-López, M., et al. (2021). Polymer Conjugates of Antimicrobial Peptides (AMPs) with d-Amino Acids (d-aa): State of the Art and Future Opportunities. MDPI. [[Link](#)]
- Genchi, G. (2017). D-Amino Acids in the Nervous and Endocrine Systems. PMC - PubMed Central. [[Link](#)]
- Sarkar, S., et al. (2018). Mechanical Genomic Studies Reveal the Role of d-Alanine Metabolism in Pseudomonas aeruginosa Cell Stiffness. PubMed Central. [[Link](#)]
- Wang, Y., et al. (2025). D-amino acid substitution and cyclisation enhance the stability and antimicrobial activity of arginine-rich peptides. bioRxiv. [[Link](#)]
- Ortega, M. A., & van der Donk, W. A. (2015). Post-translational Introduction of d-Alanine into Ribosomally Synthesized Peptides by the Dehydroalanine Reductase NpnJ. Journal of the American Chemical Society. [[Link](#)]
- Perkins, H. R. (2025). (PDF) The significance of D-alanyl-D-alanine termini in the biosynthesis of bacterial cell walls and the action of penicillin, vancomycin and ristocetin. ResearchGate. [[Link](#)]
- Neuhaus, F. C. (2025). (PDF) The Enzymatic Synthesis of d-Alanyl-d-alanine. ResearchGate. [[Link](#)]

- Heaton, M. P., & Neuhaus, F. C. (2011). Revised mechanism of d-alanine incorporation into cell wall polymers in Gram-positive bacteria. PMC - NIH. [\[Link\]](#)
- Wang, S., et al. (2024). Antimicrobial Peptides in Food Systems: Classification, Mechanism, and Industrial Application. MDPI. [\[Link\]](#)
- Saito, M., et al. (2007). D-amino acid dipeptide production utilizing D-alanine-D-alanine ligases with novel substrate specificity. PubMed. [\[Link\]](#)
- Rubakhin, S. S., & Sweedler, J. V. (2008). Detecting D-amino acid-containing neuropeptides using selective enzymatic digestion. Analytical and Bioanalytical Chemistry. [\[Link\]](#)
- Abram, M., et al. (2007). d-Alanine Modification of a Protease-Susceptible Outer Membrane Component by the Bordetella pertussis dra Locus Promotes Resistance to Antimicrobial Peptides and Polymorphonuclear Leukocyte-Mediated Killing. Infection and Immunity. [\[Link\]](#)
- Rubakhin, S. S., & Sweedler, J. V. (2008). Detecting d-Amino Acid-Containing Neuropeptides Using Selective Enzymatic Digestion. ACS Publications. [\[Link\]](#)
- Ghafourian, M., & Ghafourian, M. (2023). An accurate DFT study within conformational survey of the d-form serine-alanine protected dipeptide. PubMed Central. [\[Link\]](#)
- Jing, J., et al. (2023). Endogenous L- to D-amino acid residue isomerization modulates selectivity between distinct neuropeptide receptor family members. DigitalCommons@UNL. [\[Link\]](#)
- Stano, D., et al. (2025). Conformational studies of alanine-rich peptide using CD and FTIR spectroscopy. ResearchGate. [\[Link\]](#)
- Palmer, D. E., et al. (1992). Effects of dehydroalanine on peptide conformations. Journal of the American Chemical Society. [\[Link\]](#)
- Avbelj, F., & Baldwin, R. L. (2009). Conformational entropy of alanine versus glycine in protein denatured states. PMC. [\[Link\]](#)
- Fiveable. D-alanine-D-alanine Definition. Fiveable. [\[Link\]](#)

- Heaton, M. P., & Neuhaus, F. C. (2025). Revised mechanism of D-alanine incorporation into cell wall polymers in Gram-positive bacteria. ResearchGate. [[Link](#)]
- ResearchGate. (n.d.). Four typical conformations of the alanine dipeptide analogue. ResearchGate. [[Link](#)]

Need Custom Synthesis?

BenchChem offers custom synthesis for rare earth carbides and specific isotopic labeling.

Email: info@benchchem.com or [Request Quote Online](#).

Sources

- 1. pubs.acs.org [pubs.acs.org]
- 2. D-Amino Acids in the Nervous and Endocrine Systems - PMC [pubmed.ncbi.nlm.nih.gov]
- 3. Mechanical Genomic Studies Reveal the Role of d-Alanine Metabolism in Pseudomonas aeruginosa Cell Stiffness - PMC [pubmed.ncbi.nlm.nih.gov]
- 4. D-amino acid substitution and cyclisation enhance the stability and antimicrobial activity of arginine-rich peptides | bioRxiv [[biorxiv.org](https://www.biorxiv.org)]
- 5. An accurate DFT study within conformational survey of the d-form serine–alanine protected dipeptide - PMC [pubmed.ncbi.nlm.nih.gov]
- 6. [researchgate.net](https://www.researchgate.net) [[researchgate.net](https://www.researchgate.net)]
- 7. The role of dehydro-alanine in the design of peptides - PubMed [pubmed.ncbi.nlm.nih.gov]
- 8. pubs.acs.org [pubs.acs.org]
- 9. Conformational entropy of alanine versus glycine in protein denatured states - PMC [pubmed.ncbi.nlm.nih.gov]
- 10. [mdpi.com](https://www.mdpi.com) [[mdpi.com](https://www.mdpi.com)]
- 11. [journals.asm.org](https://www.journals.asm.org) [[journals.asm.org](https://www.journals.asm.org)]
- 12. [researchgate.net](https://www.researchgate.net) [[researchgate.net](https://www.researchgate.net)]
- 13. D-alanine synthesis and exogenous alanine affect the antimicrobial susceptibility of Staphylococcus aureus - PubMed [pubmed.ncbi.nlm.nih.gov]
- 14. [researchgate.net](https://www.researchgate.net) [[researchgate.net](https://www.researchgate.net)]

- [15. fiveable.me \[fiveable.me\]](#)
- [16. Revised mechanism of d-alanine incorporation into cell wall polymers in Gram-positive bacteria - PMC \[pmc.ncbi.nlm.nih.gov\]](#)
- [17. researchgate.net \[researchgate.net\]](#)
- [18. D-alanine synthesis and exogenous alanine affect the antimicrobial susceptibility of Staphylococcus aureus - PMC \[pmc.ncbi.nlm.nih.gov\]](#)
- [19. d-Alanine Modification of a Protease-Susceptible Outer Membrane Component by the Bordetella pertussis dra Locus Promotes Resistance to Antimicrobial Peptides and Polymorphonuclear Leukocyte-Mediated Killing - PMC \[pmc.ncbi.nlm.nih.gov\]](#)
- [20. pubs.acs.org \[pubs.acs.org\]](#)
- [21. Detecting D-amino acid-containing neuropeptides using selective enzymatic digestion - PubMed \[pubmed.ncbi.nlm.nih.gov\]](#)
- [22. digitalcommons.unl.edu \[digitalcommons.unl.edu\]](#)
- [23. mdpi.com \[mdpi.com\]](#)
- [24. pdf.benchchem.com \[pdf.benchchem.com\]](#)
- To cite this document: BenchChem. [Biological activity of peptides containing D-alanine]. BenchChem, [2026]. [Online PDF]. Available at: [\[https://www.benchchem.com/product/b2529757/docs#biological-activity-of-peptides-containing-d-alanine\]](https://www.benchchem.com/product/b2529757/docs#biological-activity-of-peptides-containing-d-alanine)

Disclaimer & Data Validity:

The information provided in this document is for Research Use Only (RUO) and is strictly not intended for diagnostic or therapeutic procedures. While BenchChem strives to provide accurate protocols, we make no warranties, express or implied, regarding the fitness of this product for every specific experimental setup.

Technical Support: The protocols provided are for reference purposes. Unsure if this reagent suits your experiment?

Need Industrial/Bulk Grade? [Request Custom Synthesis Quote](#)

BenchChem

Our mission is to be the trusted global source of essential and advanced chemicals, empowering scientists and researchers to drive progress in science and industry.

Contact

Address: 3281 E Guasti Rd

Ontario, CA 91761, United States

Phone: (601) 213-4426

Email: info@benchchem.com

[Contact our Ph.D. Support Team for a compatibility check](#)