

Halogenated 4-Azaindole Building Blocks: A Technical Guide for Modern Drug Discovery

Author: BenchChem Technical Support Team. **Date:** May 2026

Compound of Interest

Compound Name: *7-Chloro-2-iodo-1H-pyrrolo[3,2-b]pyridine*
CAS No.: 1260383-50-3
Cat. No.: B2524880

[Get Quote](#)

Abstract

The 4-azaindole scaffold, a prominent bioisostere of indole, has cemented its status as a privileged structure in medicinal chemistry.^{[1][2]} Its unique electronic properties and hydrogen bonding capabilities make it a cornerstone in the design of targeted therapeutics, particularly kinase inhibitors.^{[3][4][5]} The strategic introduction of halogen atoms onto this core is a transformative step, unlocking vast chemical space and profoundly modulating the physicochemical and pharmacological properties of the resulting molecules. This guide provides an in-depth analysis of halogenated 4-azaindole building blocks, navigating through their strategic importance, synthesis, and application. We will explore the causality behind synthetic choices, present detailed experimental protocols, and review case studies where these building blocks have been pivotal in advancing drug discovery programs.

The Strategic Imperative of Halogenation

The decision to introduce a halogen to the 4-azaindole core is a deliberate strategy driven by the need to fine-tune molecular properties for optimal therapeutic performance. Halogens are

not mere placeholders; they are versatile tools that exert powerful electronic and steric effects, serve as critical handles for synthetic diversification, and can directly participate in target binding.

Modulating Physicochemical and ADME Properties

The presence of a nitrogen atom in the 4-azaindole ring already differentiates its properties from indole, often leading to improved aqueous solubility.[1][6] Halogenation further refines these characteristics:

- **Lipophilicity and Permeability:** The addition of halogens systematically increases lipophilicity (logP), a critical parameter for cell membrane permeability. The effect is graduated, following the order $F < Cl < Br < I$, allowing for precise control over the molecule's ability to reach its biological target.
- **Metabolic Stability:** Halogenation at a metabolically susceptible position can block enzymatic degradation (e.g., by Cytochrome P450 enzymes), thereby increasing the compound's half-life and bioavailability.[7]
- **Acidity/Basicity (pKa):** The electron-withdrawing nature of halogens can modulate the pKa of the pyrrole N-H and the pyridine nitrogen, influencing ionization state at physiological pH and affecting target engagement and solubility.[3]

Enhancing Target Engagement and Potency

Halogen atoms can significantly enhance binding affinity through specific, high-value interactions:

- **Halogen Bonding:** A halogen bond is a non-covalent interaction where the electropositive region on a halogen atom (the σ -hole) interacts with a Lewis base, such as a carbonyl oxygen or an amine in a protein's active site. This interaction can be a powerful contributor to binding affinity and selectivity.
- **Hydrophobic and Steric Interactions:** Halogens can occupy hydrophobic pockets within a target protein, displacing water molecules and leading to an entropically favorable binding event. Their defined size allows for the optimization of steric fit, improving potency.[8]

A Gateway to Chemical Diversity

Perhaps the most significant role of halogenated 4-azaindoles is as versatile synthetic intermediates.[7] The carbon-halogen bond is a prime anchor point for a host of palladium-catalyzed cross-coupling reactions, enabling the rapid elaboration of the core structure and the exploration of structure-activity relationships (SAR).

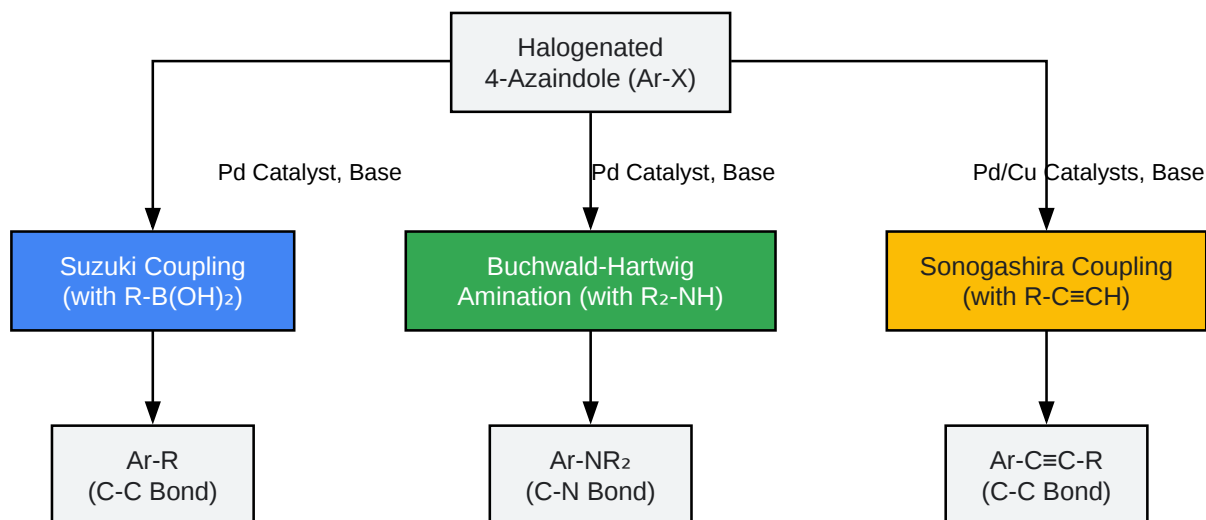

[Click to download full resolution via product page](#)

Figure 1: Versatility of halogenated 4-azaindoles in cross-coupling.

Synthetic Methodologies: A Chemist's Toolkit

The synthesis of halogenated 4-azaindoles can be broadly categorized into two strategic approaches: direct halogenation of a pre-formed 4-azaindole core or construction of the bicyclic system from pre-halogenated precursors. The choice of method depends on the desired regiochemistry and the availability of starting materials.

Regioselective Halogenation of the 4-Azaindole Core

The pyrrole ring of the 4-azaindole system is electron-rich and thus more susceptible to electrophilic substitution than the pyridine ring.

The C3 position is the most electronically activated site for electrophilic attack.

- Classical Electrophilic Halogenation: Reagents like N-bromosuccinimide (NBS), N-chlorosuccinimide (NCS), and N-iodosuccinimide (NIS) are commonly used. However, these can sometimes lead to over-halogenation or side reactions.
- Copper(II) Halide-Mediated Halogenation: A milder and highly regioselective method involves the use of copper(II) bromide (CuBr_2) or copper(II) chloride (CuCl_2). This approach offers excellent yields and is practical for large-scale synthesis, avoiding harsh conditions.[9][10] The reaction proceeds efficiently at room temperature and provides the 3-halo-4-azaindole with high purity.
- Electrochemical Halogenation: A sustainable and modern approach involves an electrochemical cascade that combines N-acylation with C3-halogenation.[7][11] This method avoids the need for chemical oxidants and provides a streamlined route to 3-halogenated N-acyl azaindoles.[7]
- Enzymatic Halogenation: Biocatalytic methods using halogenase enzymes offer unparalleled regioselectivity under environmentally benign aqueous conditions.[12]



[Click to download full resolution via product page](#)

Figure 2: General workflow for C3-halogenation of 4-azaindole.

This protocol is adapted from methodologies proven to be robust and high-yielding.[9][10]

- Preparation: To a solution of 4-azaindole (1.0 eq) in acetonitrile (MeCN, ~0.2 M), add copper(II) bromide (CuBr_2 , 1.1-1.5 eq) in one portion at room temperature.
- Reaction: Stir the resulting dark green to black suspension vigorously at room temperature. The reaction is typically complete within 2-4 hours. Monitor progress by TLC or LC-MS, observing the disappearance of the starting material.

- **Work-up:** Upon completion, concentrate the reaction mixture under reduced pressure. Partition the residue between a saturated aqueous solution of ammonium hydroxide (NH₄OH) and ethyl acetate (EtOAc). The aqueous layer will turn deep blue, indicating the complexation of copper salts.
- **Extraction:** Separate the layers and extract the aqueous phase with additional EtOAc (3x).
- **Purification:** Combine the organic layers, wash with brine, dry over anhydrous sodium sulfate (Na₂SO₄), filter, and concentrate in vacuo. The crude product can often be purified by recrystallization or flash column chromatography on silica gel to afford the 3-bromo-4-azaindole as a crystalline solid.

Self-Validation & Trustworthiness: The choice of a Cu(II) salt provides high regioselectivity for the C3 position, minimizing the formation of di-brominated species. The ammonia work-up is critical; it effectively removes the copper catalyst from the organic phase by forming a water-soluble tetraamminecopper(II) complex, which greatly simplifies purification.

Synthesis from Halogenated Precursors

To obtain halogenation at the pyridine ring (C5, C6, or C7), it is often more efficient to build the 4-azaindole scaffold from an appropriately substituted pyridine.

- **Bartoli Indole Synthesis:** This method reacts a nitro-pyridine with an excess of a vinyl Grignard reagent.^{[13][14]} Using a halogenated nitropyridine as the starting material allows for the formation of a halogenated 4-azaindole. The presence of a halogen on the pyridine ring has been shown to improve the yield of this reaction.^[13]
- **Palladium-Catalyzed Cascade Reactions:** A powerful strategy involves the palladium-catalyzed reaction between an amino-dihalopyridine and an alkyne or ketone.^{[2][15][16]} The regioselectivity can be controlled by the differential reactivity of the halogens (e.g., Br vs. Cl), enabling a facile and convergent synthesis.^[15]

Applications in Drug Discovery: Illustrative Case Studies

The utility of halogenated 4-azaindoles is best demonstrated through their successful application in the development of potent and selective inhibitors for various therapeutic targets.

Compound Class/Example	Target	Halogenation Pattern	Role of Halogen & Significance	Reference
p38 MAP Kinase Inhibitors	p38 MAP Kinase	3-Aryl-4-azaindole (often with F on the aryl group)	<p>The 4-azaindole core provides key hydrogen bonds in the ATP binding site. Halogenation of appended aryl rings is crucial for optimizing potency and pharmacokinetic properties.</p>	[17][18]
TGF-βRI Inhibitors	TGF-β Receptor 1	3-(Pyridin-2-yl)-4-azaindole	<p>The core scaffold provides potent inhibition. Halogenation (e.g., difluoromethyl group) on the pyridine substituent was explored to modulate properties and maintain high activity for immuno-oncology applications.</p>	[19]
FLT3 Inhibitors	Fms-Like Tyrosine Kinase 3	Varied substitutions	<p>SAR studies revealed that sub-nanomolar potency could be achieved with</p>	[20]

			azaindole scaffolds. Halogen substituents are key for exploring the topology of the kinase active site.
Antifungal Agents	Fungal targets	Di-halogenated (e.g., 4,6-dibromoindole)	Although on the indole core, this study highlights that halogenation at specific positions is optimal for antifungal activity due to enhanced hydrophobic and electron-withdrawing effects. This principle is transferable to the azaindole scaffold. [8]

The prevalence of the 4-azaindole core in kinase inhibitors is particularly noteworthy. The pyridine nitrogen can act as a hydrogen bond acceptor, mimicking the interaction of the adenine portion of ATP with the hinge region of the kinase active site.[3][4][5] Halogenated substituents attached to this core then explore deeper pockets, providing both potency and selectivity.

Conclusion and Future Outlook

Halogenated 4-azaindole building blocks are indispensable tools in the arsenal of the modern medicinal chemist. Their strategic use allows for the systematic optimization of drug candidates

by modulating physicochemical properties, enhancing target affinity, and providing a versatile platform for synthetic diversification. The evolution from classical halogenation methods to more sustainable electrochemical and biocatalytic approaches continues to broaden the accessibility and utility of these scaffolds. Future innovations will likely focus on developing methods for novel and previously inaccessible halogenation patterns, further expanding the chemical space that can be explored in the relentless pursuit of safer and more effective medicines.

References

- Gallou, F., Reeves, J. T., Tan, Z., Song, J. J., Yee, N. K., Harcken, C., Liu, P., Thomson, D., & Senanayake, C. H. (2007). Practical Regioselective Bromination of Azaindoles and Diazaindoles. *SYNLETT*, 2007(02), 0211–0214. [[Link](#)]
- Pramod, S., & Olofsson, B. (2023). Electrochemical Cascade Amidation and C-H Halogenation of Azaindoles. *ChemRxiv*. [[Link](#)]
- Baudin, M. L., et al. (2014). The Azaindole Framework in the Design of Kinase Inhibitors. *Molecules*, 19(12), 19936-19963. [[Link](#)]
- Kim, Y., et al. (2025). Antifungal Activities of Multi-Halogenated Indoles Against Drug-Resistant *Candida* Species. *International Journal of Molecular Sciences*. [[Link](#)]
- Goldstein, D. M., et al. (2003). Design and synthesis of 4-azaindoles as inhibitors of p38 MAP kinase. *Journal of Medicinal Chemistry*, 46(22), 4702-4713. [[Link](#)]
- Wang, G., et al. (2014). Rhodium-Catalyzed Regioselective C–H Chlorination of 7-Azaindoles Using 1,2-Dichloroethane. *Organic Letters*, 16(19), 5224-5227. [[Link](#)]
- Gallou, F., et al. (2007). Practical Regioselective Bromination of Azaindoles and Diazaindoles. *ResearchGate*. [[Link](#)]
- Paul, C. E., et al. (2022). Indole and azaindole halogenation catalyzed by the RebH enzyme variant 3-LSR utilizing co-purified *E. coli* reductase. *Frontiers in Catalysis*. [[Link](#)]
- Jeanty, M., Suzenet, F., & Guillaumet, G. (2008). Synthesis of C3-substituted 4-azaindoles: an easy access to 4-azamelatonin and protected 4-azatryptophan. *The Journal of Organic Chemistry*, 73(12), 2932-2935. [[Link](#)]

Chemistry, 73(18), 7390-7393. [\[Link\]](#)

- Baudin, M. L., et al. (2014). The Azaindole Framework in the Design of Kinase Inhibitors. ResearchGate. [\[Link\]](#)
- Unzue, A., et al. (2023). Approved Small-Molecule ATP-Competitive Kinases Drugs Containing Indole/Azaindole/Oxindole Scaffolds: R&D and Binding Patterns Profiling. Molecules, 28(2), 859. [\[Link\]](#)
- Lu, G., et al. (2020). Exploring 6-Azaindole and 7-Azaindole Rings for Developing Cannabinoid Receptor 1 Allosteric Modulators. Molecules, 25(11), 2636. [\[Link\]](#)
- Goldstein, D. M., et al. (2003). Design and Synthesis of 4-Azaindoles as Inhibitors of p38 MAP Kinase. Journal of Medicinal Chemistry, 46(22), 4702-4713. [\[Link\]](#)
- Baudin, M. L., et al. (2014). The Azaindole Framework in the Design of Kinase Inhibitors. Molecules, 19(12), 19936-19963. [\[Link\]](#)
- Boyles, D. C., et al. (2020). Discovery of 4-Azaindole Inhibitors of TGF β RI as Immunology Agents. ResearchGate. [\[Link\]](#)
- Nazaré, M., et al. (2004). Facile synthesis of 4- and 7-azaindoles from the corresponding imines by palladium-catalyzed cascade C–C and C–N coupling. Organic & Biomolecular Chemistry, 2(23), 3418-3420. [\[Link\]](#)
- Simionescu, D., et al. (2022). Recent Advances in the Synthesis and Properties of 4-, 5-, 6- or 7-Azaindoles. ResearchGate. [\[Link\]](#)
- De la Rosa, M., et al. (2020). Bioisosteric Replacement as a Tool in Anti-HIV Drug Design. Viruses, 12(3), 277. [\[Link\]](#)
- Reddy, T. S., et al. (2019). Amide derivatives of 4-azaindole: Design, synthesis, and EGFR targeting anticancer agents. Journal of Enzyme Inhibition and Medicinal Chemistry, 34(1), 1633-1641. [\[Link\]](#)
- Kumar, S., et al. (2012). Palladium-catalyzed C–N and C–O bond formation of N-substituted 4-bromo-7-azaindoles with amides, amines, amino acid esters and phenols. Beilstein Journal

of Organic Chemistry, 8, 1485-1492. [\[Link\]](#)

- Zhang, Y., et al. (2022). Bioisosteric replacements of the indole moiety for the development of a potent and selective PI3K δ inhibitor: Design, synthesis and biological evaluation. ResearchGate. [\[Link\]](#)
- Mushtaq, N., et al. (2008). SYNTHESIS AND PHARMACOLOGICAL ACTIVITIES OF 7-AZAINDOLE DERIVATIVES. Pakistan Journal of Pharmaceutical Sciences, 21(3), 250-253. [\[Link\]](#)
- Dobson, D. R., et al. (2002). A General Method for the Preparation of 4- and 6-Azaindoles. The Journal of Organic Chemistry, 67(8), 2741-2744. [\[Link\]](#)
- CN102746295A - Preparation method for 4-substituted-7-azaindole. (2012).
- Patani, G. A., & LaVoie, E. J. (1996). Bioisosterism: A Rational Approach in Drug Design. Chemical Reviews, 96(8), 3147-3176. [\[Link\]](#)
- Dobson, D. R., et al. (2002). A General Method for the Preparation of 4- and 6-Azaindoles. ResearchGate. [\[Link\]](#)
- Ferreira, I. C. F. R., et al. (2018). Metal-Catalyzed Cross-Coupling Reactions on Azaindole Synthesis and Functionalization. Catalysts, 8(10), 456. [\[Link\]](#)
- van der Stelt, M., et al. (2019). Comprehensive structure-activity-relationship of azaindoles as highly potent FLT3 inhibitors. Bioorganic & Medicinal Chemistry, 27(5), 692-699. [\[Link\]](#)
- Pramod, S., & Olofsson, B. (2025). Electrochemical Cascade Amidation and C-H Halogenation of Azaindoles. ChemRxiv. [\[Link\]](#)
- Henderson, J. L., et al. (2010). Palladium-Catalyzed Amination of Unprotected Halo-7-azaindoles. Organic Letters, 12(20), 4438-4441. [\[Link\]](#)
- Pollastri, M. P., et al. (2024). Pharmacophore Identification and Structure-Activity Relationship Analysis of a Series of Substituted Azaindoles as Inhibitors of Trypanosoma brucei. Journal of Medicinal Chemistry, 67(16), 13985-14006. [\[Link\]](#)

- Koovits, P. J., et al. (2021). Structure-activity relationship of 4-azaindole-2-piperidine derivatives as agents against *Trypanosoma cruzi*. CIBFar. [\[Link\]](#)
- Organic Chemistry Portal. (n.d.). Azaindole synthesis. Organic Chemistry Portal. [\[Link\]](#)
- Aissaoui, H., et al. (2021). Synthetic route for the preparation of the 4-azaindole derivatives. ResearchGate. [\[Link\]](#)
- Sharma, S., et al. (2022). Recent advances in the halogenated spirooxindoles as novel anticancer scaffolds: chemistry and bioactivity approach. RSC Medicinal Chemistry, 13(9), 1021-1042. [\[Link\]](#)
- Wang, Y., et al. (2023). Recent Advances in Synthetic Routes to Azacycles. Molecules, 28(6), 2686. [\[Link\]](#)
- Kumar, A., et al. (2021). Azaindole Therapeutic Agents. Current Medicinal Chemistry, 28(1), 1-2. [\[Link\]](#)

Need Custom Synthesis?

BenchChem offers custom synthesis for rare earth carbides and specific isotopic labeling.

Email: info@benchchem.com or [Request Quote Online](#).

Sources

- 1. img01.pharmablock.com [img01.pharmablock.com]
- 2. pdf.benchchem.com [pdf.benchchem.com]
- 3. The Azaindole Framework in the Design of Kinase Inhibitors - PMC [pmc.ncbi.nlm.nih.gov]
- 4. researchgate.net [researchgate.net]
- 5. mdpi.com [mdpi.com]
- 6. Exploring 6-Azaindole and 7-Azaindole Rings for Developing Cannabinoid Receptor 1 Allosteric Modulators - PMC [pmc.ncbi.nlm.nih.gov]
- 7. chemrxiv.org [chemrxiv.org]
- 8. mdpi.com [mdpi.com]

- [9. Thieme E-Journals - Synlett / Abstract \[thieme-connect.com\]](#)
- [10. researchgate.net \[researchgate.net\]](#)
- [11. chemrxiv.org \[chemrxiv.org\]](#)
- [12. Indole and azaindole halogenation catalyzed by the RebH enzyme variant 3-LSR utilizing co-purified E. coli reductase - PMC \[pmc.ncbi.nlm.nih.gov\]](#)
- [13. pubs.acs.org \[pubs.acs.org\]](#)
- [14. researchgate.net \[researchgate.net\]](#)
- [15. Facile synthesis of 4- and 7-azaindoles from the corresponding imines by palladium-catalyzed cascade C–C and C–N coupling - Organic & Biomolecular Chemistry \(RSC Publishing\) \[pubs.rsc.org\]](#)
- [16. Metal-Catalyzed Cross-Coupling Reactions on Azaindole Synthesis and Functionalization - PMC \[pmc.ncbi.nlm.nih.gov\]](#)
- [17. Design and synthesis of 4-azaindoles as inhibitors of p38 MAP kinase - PubMed \[pubmed.ncbi.nlm.nih.gov\]](#)
- [18. pubs.acs.org \[pubs.acs.org\]](#)
- [19. researchgate.net \[researchgate.net\]](#)
- [20. Comprehensive structure-activity-relationship of azaindoles as highly potent FLT3 inhibitors - PubMed \[pubmed.ncbi.nlm.nih.gov\]](#)
- [To cite this document: BenchChem. \[Halogenated 4-Azaindole Building Blocks: A Technical Guide for Modern Drug Discovery\]. BenchChem, \[2026\]. \[Online PDF\]. Available at: \[https://www.benchchem.com/product/b2524880/docs#halogenated-4-azaindole-building-blocks-a-technical-guide-for-modern-drug-discovery\]](#)

Disclaimer & Data Validity:

The information provided in this document is for Research Use Only (RUO) and is strictly not intended for diagnostic or therapeutic procedures. While BenchChem strives to provide accurate protocols, we make no warranties, express or implied, regarding the fitness of this product for every specific experimental setup.

Technical Support: The protocols provided are for reference purposes. Unsure if this reagent suits your experiment?

Need Industrial/Bulk Grade? [Request Custom Synthesis Quote](#)

BenchChem

Our mission is to be the trusted global source of essential and advanced chemicals, empowering scientists and researchers to drive progress in science and industry.

Contact

Address: 3281 E Guasti Rd

Ontario, CA 91761, United States

Phone: (601) 213-4426

Email: info@benchchem.com

[Contact our Ph.D. Support Team for a compatibility check](#)