

# Synthesis of 1-(3,3-Dimethylcyclobutyl)ethanamine Hydrochloride: A Comprehensive Application Note

**Author:** BenchChem Technical Support Team. **Date:** April 2026

## Compound of Interest

Compound Name:	1-(3,3-Dimethylcyclobutyl)ethanamine;hydrochloride
CAS No.:	2408964-13-4
Cat. No.:	B2522724

[Get Quote](#)

Audience: Researchers, Medicinal Chemists, and Drug Development Professionals  
Content Type: Technical Guide & Experimental Protocols

## Mechanistic Rationale & Retrosynthetic Strategy

The cyclobutane motif has emerged as a privileged scaffold in modern drug discovery. By enforcing conformational restriction and increasing the sp<sup>3</sup> character of a molecule, cyclobutanes significantly improve metabolic stability and pharmacokinetic profiles compared to their flexible alkyl or planar aryl counterparts[1]. The target molecule, 1-(3,3-Dimethylcyclobutyl)ethanamine hydrochloride[2], contains a primary amine paired with a sterically demanding, gem-dimethyl-substituted cyclobutane ring.

Synthesizing sterically encumbered, chiral primary amines requires a highly controlled strategic approach. The protocol described herein employs a robust two-stage sequence:

- The Weinreb Ketone Synthesis: Direct Grignard addition to a carboxylic acid or ester often yields over-alkylation byproducts (tertiary alcohols). By first converting 3,3-dimethylcyclobutanecarboxylic acid to a Weinreb amide, the subsequent addition of methylmagnesium bromide forms a stable, five-membered chelated tetrahedral intermediate. This chelate resists collapse until the reaction is quenched, ensuring exclusive formation of the methyl ketone[3].
- Ellman's Asymmetric Reductive Amination: To install the amine with high stereofidelity, the ketone is condensed with Ellman's auxiliary (tert-butanesulfinamide). The resulting sulfinyl imine is reduced diastereoselectively. The bulky tert-butyl group and the coordination of the reducing agent to the sulfinyl oxygen lock the transition state, directing hydride attack to the less hindered face[4].

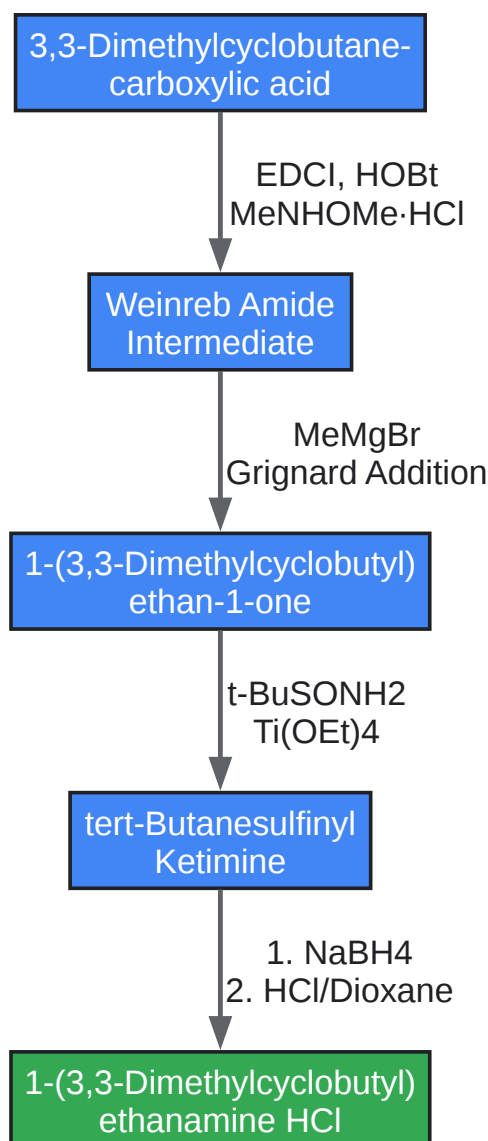

[Click to download full resolution via product page](#)

Synthetic workflow for 1-(3,3-Dimethylcyclobutyl)ethanamine HCl via Weinreb-Ellman sequence.

## Quantitative Data Summary

The following table summarizes the key intermediates, their physical properties, and expected metrics when executing this workflow at a 10–50 mmol scale.

Intermediate / Product	CAS Number	Molecular Weight	Typical Yield	Target Purity (LC-MS)
3,3-Dimethylcyclobutanecarboxylic acid	34970-18-8	128.17 g/mol	N/A (Starting Material)	>98%
N-Methoxy-N,3,3-trimethylcyclobutane-1-carboxamide	N/A	171.24 g/mol	85 – 90%	>95%
1-(3,3-Dimethylcyclobutyl)ethan-1-one	34970-17-7	126.20 g/mol	88 – 92%	>95%
Ellman's Ketimine Intermediate	N/A	229.38 g/mol	75 – 82%	>90%
1-(3,3-Dimethylcyclobutyl)ethanamine HCl	2408964-13-4	163.69 g/mol	80 – 85% (over 2 steps)	>99% (ee >98%)

## Experimental Protocols

Note: The following protocols are designed as self-validating systems. Mandatory In-Process Controls (IPCs) are included to ensure causality and verification at each step.

## Synthesis of the Weinreb Amide

Causality: EDCI activates the carboxylic acid to form an O-acylisourea, which is trapped by HOBt to form a reactive, yet stable, active ester. N,N-Diisopropylethylamine (DIPEA) is utilized to liberate N,O-dimethylhydroxylamine from its hydrochloride salt without acting as a competing nucleophile.

- Setup: In a flame-dried round-bottom flask under nitrogen, dissolve 3,3-dimethylcyclobutanecarboxylic acid (1.0 equiv) in anhydrous Dichloromethane (DCM, 0.2 M).
- Activation: Add EDCI (1.2 equiv) and HOBt (1.2 equiv). Stir at room temperature for 15 minutes.
- Amidation: Add N,O-dimethylhydroxylamine hydrochloride (1.2 equiv) followed by the dropwise addition of DIPEA (2.5 equiv). Stir at room temperature for 12 hours.
- IPC Validation: Analyze a 10  $\mu$ L aliquot via LC-MS. The reaction is complete when the starting acid mass is fully replaced by the amide mass ( $m/z$   $[M+H]^+$  172.2).
- Workup: Wash the organic layer sequentially with 1M aqueous HCl (to remove unreacted amine and DIPEA), saturated aqueous  $\text{NaHCO}_3$  (to remove unreacted acid), and brine. Dry over  $\text{Na}_2\text{SO}_4$ , filter, and concentrate under reduced pressure.

## Grignard Addition to Form the Methyl Ketone

Causality: The bidentate coordination of the magnesium cation to both the carbonyl oxygen and the methoxy oxygen of the Weinreb amide stabilizes the tetrahedral intermediate, strictly preventing a second equivalent of methylmagnesium bromide from adding[3].

- Setup: Dissolve the Weinreb amide (1.0 equiv) in anhydrous Tetrahydrofuran (THF, 0.3 M) under an argon atmosphere. Cool the solution to 0  $^\circ\text{C}$  using an ice-water bath.
- Addition: Dropwise, add Methylmagnesium bromide (MeMgBr, 3.0 M in diethyl ether, 1.5 equiv) over 30 minutes to maintain the internal temperature below 5  $^\circ\text{C}$ .

- Reaction: Remove the ice bath and allow the reaction to warm to room temperature, stirring for 2 hours.
- IPC Validation: Quench a 50  $\mu\text{L}$  aliquot in saturated  $\text{NH}_4\text{Cl}$  and extract with EtOAc. TLC (4:1 Hexane/EtOAc) should show complete consumption of the Weinreb amide (UV active) and the appearance of a new, higher  $R_f$  spot ( $\text{KMnO}_4$  active).
- Workup: Carefully quench the reaction at 0  $^\circ\text{C}$  by the slow addition of saturated aqueous  $\text{NH}_4\text{Cl}$ . Extract the aqueous phase three times with EtOAc. Wash combined organics with brine, dry over  $\text{MgSO}_4$ , and concentrate to yield 1-(3,3-dimethylcyclobutyl)ethan-1-one.

## Condensation with Ellman's Auxiliary (Ketimine Formation)

Causality: Ketones are inherently less electrophilic than aldehydes. Titanium(IV) ethoxide ( $\text{Ti}(\text{OEt})_4$ ) is employed because it acts as a Lewis acid to activate the ketone carbonyl while simultaneously acting as an irreversible water scavenger, driving the condensation to completion[4].

- Setup: Dissolve the methyl ketone (1.0 equiv) and (R)- or (S)-tert-butanesulfinamide (1.1 equiv) in anhydrous THF (0.5 M).
- Condensation: Add  $\text{Ti}(\text{OEt})_4$  (2.0 equiv) in one portion. Equip the flask with a reflux condenser and heat to 60  $^\circ\text{C}$  for 18 hours.
- IPC Validation: Monitor via LC-MS. The ketone peak should be minimized, and the ketimine mass ( $m/z$   $[\text{M}+\text{H}]^+$  230.4) should dominate.
- Workup (Critical Step): Cool to room temperature and pour the mixture into an equal volume of brine while stirring vigorously. A thick white suspension of  $\text{TiO}_2$  will form. Do not attempt to use a separatory funnel yet. Filter the suspension through a pad of Celite, washing the filter cake thoroughly with EtOAc. Transfer the filtrate to a separatory funnel, isolate the organic layer, dry over  $\text{Na}_2\text{SO}_4$ , and concentrate.

## Diastereoselective Reduction & Salt Formation

Causality: Sodium borohydride (NaBH<sub>4</sub>) coordinates to the sulfinyl oxygen, creating a rigid six-membered transition state. The bulky tert-butyl group shields one face of the imine, directing the hydride to attack from the opposite, less hindered face, resulting in exceptional diastereomeric excess[4]. Subsequent treatment with anhydrous HCl cleanly cleaves the N-S bond without degrading the cyclobutane ring.

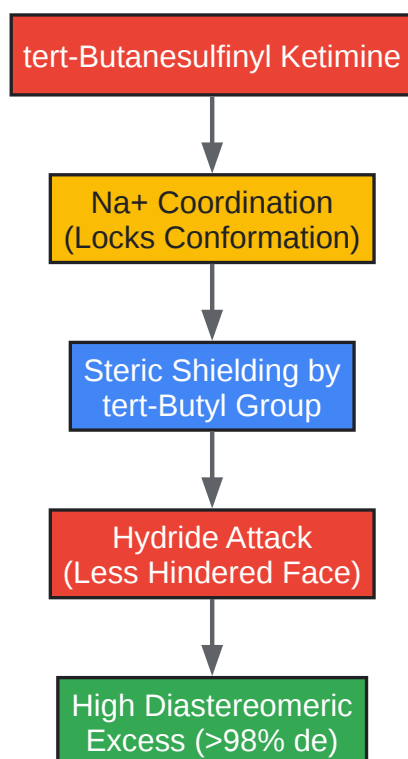

[Click to download full resolution via product page](#)

Mechanism of diastereoselective ketimine reduction directed by Ellman's sulfinamide auxiliary.

- Reduction: Dissolve the crude ketimine in a 9:1 mixture of THF/MeOH (0.2 M) and cool to -50 °C. Add NaBH<sub>4</sub>(3.0 equiv) in portions. Stir for 4 hours, slowly warming to 0 °C.
- Quench: Quench with saturated NH<sub>4</sub>Cl, extract with EtOAc, dry, and concentrate.
- Deprotection: Dissolve the resulting sulfinamide in anhydrous Methanol (0.2 M). Add 4M HCl in Dioxane (3.0 equiv). Stir at room temperature for 2 hours.
- IPC Validation: LC-MS will show the disappearance of the sulfinamide mass and the appearance of the free amine (m/z[M+H]<sup>+</sup> 128.2).

- Isolation: Concentrate the solution to dryness. Triturate the resulting crude solid with cold diethyl ether to remove organic impurities and sulfinate byproducts. Filter to collect 1-(3,3-Dimethylcyclobutyl)ethanamine hydrochloride as a highly pure, white crystalline solid.

## References

- [2] trans-3-Methoxy-N-methylcyclobutanamine Hydrochloride-AccelaChem. Source: AccelaChem. URL: [\[Link\]](#)
- 3,3-Dimethylcyclobutanecarboxylic acid. Source: 3ASenrise. URL: [\[Link\]](#)
- [1] Cyclobutanes in Small-Molecule Drug Candidates. Source: PubMed Central (PMC). URL: [\[Link\]](#)
- [3] Weinreb ketone synthesis. Source: Wikipedia. URL: [\[Link\]](#)
- [4] N-tert-butanefulfinyl imines: versatile intermediates for the asymmetric synthesis of amines. Source: PubMed. URL: [\[Link\]](#)

### Need Custom Synthesis?

BenchChem offers custom synthesis for rare earth carbides and specific isotopic labeling.

Email: [info@benchchem.com](mailto:info@benchchem.com) or [Request Quote Online](#).

## Sources

- 1. Cyclobutanes in Small-Molecule Drug Candidates - PMC [[pmc.ncbi.nlm.nih.gov](https://pubmed.ncbi.nlm.nih.gov)]
- 2. 2817369-17-6,trans-3-Methoxy-N-methylcyclobutanamine Hydrochloride-AccelaChem|AccelaChemBio|Accela design, synthesis, manufacture and market advanced R&D chemicals;韶远科技（上海）有限公司 [[accelachem.com](https://accelachem.com)]
- 3. Weinreb ketone synthesis - Wikipedia [[en.wikipedia.org](https://en.wikipedia.org)]
- 4. N-tert-butanefulfinyl imines: versatile intermediates for the asymmetric synthesis of amines - PubMed [[pubmed.ncbi.nlm.nih.gov](https://pubmed.ncbi.nlm.nih.gov)]
- To cite this document: BenchChem. [Synthesis of 1-(3,3-Dimethylcyclobutyl)ethanamine Hydrochloride: A Comprehensive Application Note]. BenchChem, [2026]. [Online PDF].

Available at: [<https://www.benchchem.com/product/b2522724/docs#synthesis-of-1-3-3-dimethylcyclobutyl-ethanamine-hydrochloride-a-comprehensive-application-note>]

### Disclaimer & Data Validity:

The information provided in this document is for Research Use Only (RUO) and is strictly not intended for diagnostic or therapeutic procedures. While BenchChem strives to provide accurate protocols, we make no warranties, express or implied, regarding the fitness of this product for every specific experimental setup.

**Technical Support:** The protocols provided are for reference purposes. Unsure if this reagent suits your experiment?

**Need Industrial/Bulk Grade?** [Request Custom Synthesis Quote](#)

## BenchChem

Our mission is to be the trusted global source of essential and advanced chemicals, empowering scientists and researchers to drive progress in science and industry.

### Contact

Address: 3281 E Guasti Rd  
Ontario, CA 91761, United States  
Phone: (601) 213-4426  
Email: [info@benchchem.com](mailto:info@benchchem.com)

[Contact our Ph.D. Support Team for a compatibility check](#)