

## Guide to NMR Analysis for Structural Confirmation

Author: BenchChem Technical Support Team. Dr

## Compound of Interest

Compound Name: Propargyl-PEG2-bromide  
CAS No.: 1287660-82-5  
Cat. No.: B2515300

[Get Quote](#)

For Researchers, Scientists, and Drug Development Professionals

This guide provides a comprehensive comparison and methodology for confirming the chemical structure of **Propargyl-PEG2-bromide** using Nuclear Magnetic Resonance (NMR) spectroscopy. It covers synthesizing or utilizing this bifunctional linker in applications such as Proteolysis Targeting Chimeras (PROTACs) and Click Chemistry.

## Structural Overview

**Propargyl-PEG2-bromide** is a heterobifunctional linker featuring a terminal alkyne (propargyl group) for copper-catalyzed azide-alkyne cycloaddition (CuAAC) and a polyethylene glycol (PEG) chain, enhancing solubility and providing a flexible spacer.

Structure:

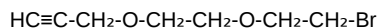

Chemical structure diagram showing the propargyl group (HC≡C-CH<sub>2</sub>-) attached to a PEG chain (-O-CH<sub>2</sub>-CH<sub>2</sub>-O-CH<sub>2</sub>-CH<sub>2</sub>-) which is terminated with a bromide group (-Br).

## Data Presentation: Predicted NMR Analysis

The following tables summarize the expected <sup>1</sup>H and <sup>13</sup>C NMR chemical shifts for **Propargyl-PEG2-bromide** in a standard deuterated solvent such as DMSO-d<sub>6</sub>.

Table 1: Predicted <sup>1</sup>H NMR Data for **Propargyl-PEG2-bromide**

Label	Assignment	Predicted Chemical Shift (δ, ppm)
a	≡C-H	2.4 - 2.5
b	-C≡C-CH <sub>2</sub> -O-	4.1 - 4.2
c	-O-CH <sub>2</sub> -CH <sub>2</sub> -O-	3.6 - 3.7
d	-O-CH <sub>2</sub> -CH <sub>2</sub> -O-	3.6 - 3.7
e	-O-CH <sub>2</sub> -CH <sub>2</sub> -Br	3.75 - 3.85
f	-CH <sub>2</sub> -CH <sub>2</sub> -Br	3.45 - 3.55

Note: The signals for protons 'c' and 'd' in the PEG linker may overlap, forming a complex multiplet.

Table 2: Predicted <sup>13</sup>C NMR Data for **Propargyl-PEG2-bromide**

Assignment	Predicted Chemical S
$\equiv\text{C-H}$	74 - 75
$-\text{C}\equiv\text{C}-$	79 - 80
$-\text{C}\equiv\text{C}-\text{CH}_2-\text{O}-$	58 - 59
$-\text{O}-\text{CH}_2-\text{CH}_2-\text{O}-$ (position c)	69 - 70
$-\text{O}-\text{CH}_2-\text{CH}_2-\text{O}-$ (position d)	70 - 71
$-\text{O}-\text{CH}_2-\text{CH}_2-\text{Br}$	71 - 72
$-\text{CH}_2-\text{CH}_2-\text{Br}$	30 - 31

## Comparison with an Alternative: Propargyl-PEG2-OH

To highlight the sensitivity of NMR in structural determination, we compare the expected  $^1\text{H}$  NMR spectrum of **Propargyl-PEG2-bromide** with its hydroxyl protons.

Table 3:  $^1\text{H}$  NMR Comparison of Terminal Groups

Compound	Terminal Group	Structure Fragment
Propargyl-PEG2-bromide	Bromo	$-\text{O}-\text{CH}_2-\text{CH}_2-\text{Br}$
Propargyl-PEG2-OH[1][2]	Hydroxyl	$-\text{O}-\text{CH}_2-\text{CH}_2-\text{OH}$

The substitution of the electronegative bromine with a hydroxyl group results in a downfield shift (from  $\sim 3.5$  ppm to  $\sim 3.75$  ppm) for the adjacent methylene protons. This chemical shift difference allows for unambiguous confirmation of the terminal functional group.

## Experimental Protocols

A detailed and standardized protocol is crucial for obtaining high-quality, reproducible NMR data.[3][4]

### Sample Preparation

- Quantity: Weigh 5-10 mg of the **Propargyl-PEG2-bromide** sample for  $^1\text{H}$  NMR. For  $^{13}\text{C}$  NMR, a more concentrated sample of 20-50 mg is recommended.
- Solvent: Add approximately 0.6-0.7 mL of a deuterated solvent (e.g.,  $\text{CDCl}_3$ ) containing 0.03% v/v Tetramethylsilane (TMS) as an internal reference.
- Dissolution: Ensure the sample is fully dissolved. Vortex the sample gently if necessary.
- Filtration: To remove any particulate matter which can degrade spectral quality, filter the solution through a small plug of glass wool packed into a Pasteur pipette.
- Labeling: Clearly label the NMR tube with the sample identification.

### NMR Data Acquisition

The following are general parameters for a 400 MHz NMR spectrometer. These may need to be optimized for different instruments.

$^1\text{H}$  NMR Spectroscopy:

- Pulse Program: Standard single-pulse (zg30 or similar).
- Number of Scans (NS): 8-16 scans.
- Relaxation Delay (D1): 1-5 seconds. A longer delay ( $5 \times T_1$ ) is necessary for accurate integration in quantitative NMR (qNMR).
- Acquisition Time (AQ): 2-4 seconds.

- Spectral Width (SW): 16 ppm (-2 to 14 ppm).
- Temperature: 298 K (25 °C).

<sup>13</sup>C NMR Spectroscopy:

- Pulse Program: Proton-decoupled single-pulse (zgpg30 or similar).
- Number of Scans (NS): 1024-4096 scans (or more, depending on concentration).
- Relaxation Delay (D1): 2 seconds.
- Acquisition Time (AQ): 1-2 seconds.
- Spectral Width (SW): 240 ppm (-10 to 230 ppm).
- Temperature: 298 K (25 °C).

## Visualization of Analytical Workflow

The logical flow for confirming the structure of **Propargyl-PEG2-bromide** via NMR is outlined below. This process ensures a systematic approach fro

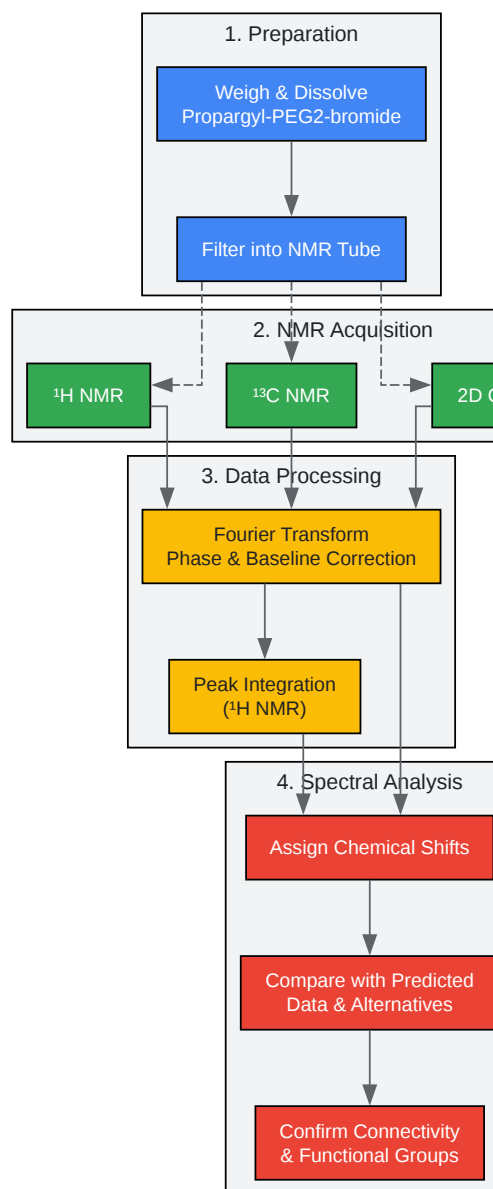

[Click to download full resolution via product](#)

Caption: Workflow for NMR-based structural verification.

#### Need Custom Synthesis?

BenchChem offers custom synthesis for rare earth carbides and specific isotopic labeling.

Email: [info@benchchem.com](mailto:info@benchchem.com) or [Request Quote Online](#).

## References

- 1. [file.leyan.com](http://file.leyan.com) [file.leyan.com]
- 2. [medchemexpress.com](http://medchemexpress.com) [medchemexpress.com]
- 3. [mdpi.com](http://mdpi.com) [mdpi.com]
- 4. [books.rsc.org](http://books.rsc.org) [books.rsc.org]

- [5. NMR Sample Preparation \[nmr.chem.umn.edu\]](#)
- To cite this document: BenchChem. [Guide to NMR Analysis for Structural Confirmation of Propargyl-PEG2-bromide]. BenchChem, [2026]. [Online confirmation-of-propargyl-peg2-bromide]

---

**Disclaimer & Data Validity:**

The information provided in this document is for Research Use Only (RUO) and is strictly not intended for diagnostic or therapeutic procedures. While fitness of this product for every specific experimental setup.

**Technical Support:** The protocols provided are for reference purposes. Unsure if this reagent suits your experiment?

**Need Industrial/Bulk Grade?** [Request Custom Synthesis Quote](#)

## BenchChem

Our mission is to be the trusted global source of essential and advanced chemicals, empowering scientists and researchers to drive progress in science and industry.

---

[Contact our Ph.D. Support Team for a con](#)

---