

Application Note: Asymmetric Transfer Hydrogenation of α -Keto Esters

Author: BenchChem Technical Support Team. **Date:** May 2026

Compound of Interest

Compound Name:	Methyl 2-(4-nitrophenyl)-2-oxoacetate
CAS No.:	57699-27-1
Cat. No.:	B2504192

[Get Quote](#)

A Practical Guide to the Enantioselective Synthesis of Chiral α -Hydroxy Esters Using Noyori-Type Catalysts

Introduction: The Importance of Chiral α -Hydroxy Esters

Chiral α -hydroxy esters are pivotal structural motifs found in a vast array of pharmaceuticals, agrochemicals, and natural products.[1] Their synthesis in high enantiomeric purity is a critical challenge in modern organic chemistry. Asymmetric transfer hydrogenation (ATH) has emerged as a powerful and practical alternative to traditional asymmetric hydrogenation, offering operational simplicity, mild reaction conditions, and avoiding the need for high-pressure hydrogen gas.[1][2][3] This protocol details a reliable method for the ATH of α -keto esters using a well-defined ruthenium(II) catalyst, affording valuable chiral α -hydroxy esters with high enantioselectivity.

Mechanism and Rationale: The Metal-Ligand Bifunctional Catalysis

The success of this transformation hinges on a "metal-ligand bifunctional" mechanism, pioneered by Noyori. The catalyst system involves a ruthenium precursor and a chiral N-tosylated diamine ligand, such as (S,S)-TsDPEN. In the presence of a hydrogen donor like formic acid, a 16-electron ruthenium hydride species is formed, which is the active catalyst.

The catalytic cycle proceeds through a concerted, six-membered pericyclic transition state.[1][4] Key mechanistic features include:

- **Hydride Transfer:** The hydride (H^-) on the ruthenium center is transferred to the electrophilic carbonyl carbon of the α -keto ester.
- **Proton Transfer:** Simultaneously, the proton (H^+) from the amine ligand is transferred to the carbonyl oxygen.
- **Irreversibility:** The use of formic acid as a hydrogen donor is advantageous as it decomposes into gaseous CO_2 , rendering the hydrogenation step effectively irreversible and preventing product racemization via a reverse reaction.[3][5]

The enantioselectivity is dictated by the precise spatial arrangement of the substrate relative to the chiral ligand in the transition state, where steric and electronic interactions (such as CH/π interactions) favor one approach over the other.[6]

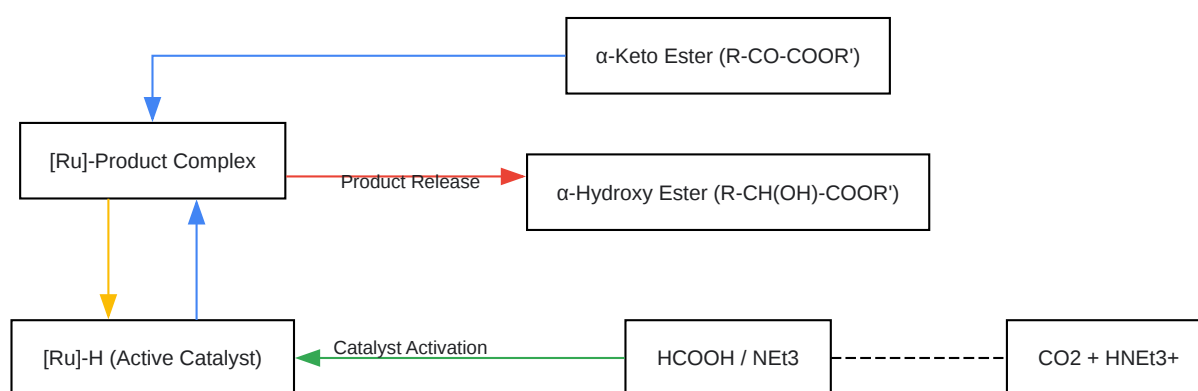

[Click to download full resolution via product page](#)

Figure 1. Simplified catalytic cycle for the asymmetric transfer hydrogenation of an α -keto ester.

Experimental Protocol

This protocol is optimized for a typical reaction on a 1.0 mmol scale. All manipulations should be performed using standard Schlenk techniques under an inert atmosphere (Argon or Nitrogen) to prevent catalyst deactivation.

Part 1: Preparation of Reagents

A. Formic Acid/Triethylamine (5:2) Azeotrope (Hydrogen Donor)

The azeotropic mixture of formic acid and triethylamine serves as both the hydrogen source and a convenient solvent.

- Charge a dry, four-necked, round-bottomed flask equipped with a magnetic stir bar, dropping funnel, thermometer, and nitrogen inlet with 34.7 mL (42.3 g, 0.9 mol) of 98% formic acid.[7]
- Cool the flask to 0-4 °C using an ice bath.
- Slowly add 50.0 mL (36.4 g, 0.36 mol) of triethylamine dropwise via the dropping funnel over ~1.5 hours, ensuring the internal temperature does not exceed 10 °C.[7]
- Once the addition is complete, allow the mixture to warm to room temperature. This stock solution is ready for use. For long-term storage, it should be kept under an inert atmosphere.

Causality Note: The exothermic reaction between formic acid and triethylamine is controlled by slow addition at low temperatures. The resulting formate salt is the active hydrogen donor. The 5:2 molar ratio has been empirically found to provide optimal rates and selectivity for many ketone reductions.[7]

B. Catalyst Precursor

The active catalyst is typically generated in situ. The common precursor is a Ru(II)-diamine complex, for example, RuCl. This complex is commercially available or can be synthesized from [RuCl₂(p-cymene)]₂ and (S,S)-TsDPEN.

Part 2: Reaction Setup and Execution

- **Flask Preparation:** To a dry 25 mL Schlenk flask equipped with a magnetic stir bar, add the catalyst precursor, RuCl (e.g., 3.2 mg, 0.005 mmol, 0.5 mol%).
- **Inert Atmosphere:** Evacuate the flask and backfill with argon or nitrogen. Repeat this cycle three times to ensure an oxygen-free environment.[7]
- **Substrate Addition:** Using a syringe, add the α -keto ester substrate (1.0 mmol) to the flask. If the substrate is a solid, it can be added along with the catalyst in step 1.
- **Solvent/Hydrogen Donor Addition:** Add 5 mL of the pre-prepared formic acid/triethylamine (5:2) azeotrope to the flask via syringe.[7]
- **Reaction:** Stir the resulting homogeneous solution at room temperature (or a specified temperature, see Table 1) and monitor the reaction progress by Thin Layer Chromatography (TLC) or High-Performance Liquid Chromatography (HPLC).

Causality Note: Maintaining a slightly positive pressure of inert gas is crucial as oxygen can oxidize and deactivate the Ru(II) catalyst.[7] The substrate-to-catalyst (S/C) ratio is a key parameter; a typical range is 100 to 1000, but can be much higher for highly active substrates. [8]

Part 3: Work-up and Purification

- **Quenching:** Upon completion, cool the reaction mixture to room temperature (if heated) and carefully quench by adding 10 mL of saturated sodium bicarbonate (NaHCO_3) solution to neutralize the excess formic acid.
- **Extraction:** Extract the aqueous layer with ethyl acetate (3 x 15 mL).
- **Washing:** Combine the organic layers and wash sequentially with 1 M HCl (1 x 10 mL) to remove triethylamine, followed by brine (1 x 10 mL).
- **Drying and Concentration:** Dry the organic phase over anhydrous sodium sulfate (Na_2SO_4), filter, and concentrate the solvent under reduced pressure using a rotary evaporator.
- **Purification:** Purify the crude product by flash column chromatography on silica gel using an appropriate eluent system (e.g., hexane/ethyl acetate) to afford the pure α -hydroxy ester.

Data Presentation: Typical Reaction Parameters

The optimal conditions can vary depending on the electronic and steric properties of the α -keto ester substrate. The following table provides a summary of typical conditions and expected outcomes for representative substrates.

Entry	Substrate (α -Keto Ester)	S/C Ratio	Temp (°C)	Time (h)	Yield (%)	ee (%)
1	Ethyl benzoylformate	200	25	12	>95	98
2	Methyl 2-oxo-4-phenylbutanoate	200	25	16	93	96
3	Ethyl pyruvate	500	28	8	>99	95
4	Ethyl 3-methyl-2-oxobutanoate	200	40	24	90	94

Data are representative and compiled from typical results in the literature. Actual results may vary.^{[8][9][10]}

Product Analysis: Verification of Enantioselectivity

The enantiomeric excess (ee) of the purified α -hydroxy ester must be determined to validate the success of the asymmetric synthesis.

Protocol: Chiral HPLC Analysis

- **Sample Preparation:** Prepare a dilute solution of the purified product (~1 mg/mL) in the mobile phase or a compatible solvent.

- Column Selection: Use a chiral stationary phase (CSP) column suitable for separating enantiomers of hydroxy esters, such as a Chiralpak AD-H or Chiralcel OD-H column.[11]
- Mobile Phase: A typical mobile phase is a mixture of n-hexane and isopropanol (e.g., 90:10 v/v). The exact ratio may require optimization.[12][13]
- Analysis: Inject the sample onto the HPLC system. The two enantiomers should appear as distinct peaks. The enantiomeric excess is calculated from the integrated peak areas (A_1 and A_2) of the two enantiomers using the formula:

$$ee (\%) = |(A_1 - A_2) / (A_1 + A_2)| \times 100$$

Causality Note: Chiral HPLC columns create a chiral environment where the two enantiomers interact differently with the stationary phase, leading to different retention times and enabling their separation.[14] The choice of column and mobile phase is critical and often determined empirically for a specific analyte.[13]

Troubleshooting Guide

Issue	Possible Cause(s)	Suggested Solution(s)
Low or No Conversion	1. Catalyst deactivation (exposure to air).2. Impure substrate or solvent.3. Insufficient reaction time or temperature.	1. Ensure rigorous inert atmosphere techniques.2. Use freshly distilled solvents and purified substrate.3. Increase reaction time or gently warm the reaction (e.g., to 40 °C).
Low Enantioselectivity (ee)	1. Incorrect catalyst enantiomer used.2. Racemization of product during workup.3. Reaction temperature is too high.	1. Verify the absolute configuration of the chiral ligand ((S,S) vs. (R,R)).2. Avoid strongly acidic or basic conditions during workup.3. Run the reaction at a lower temperature, even if it requires longer time.
Difficult Purification	1. Incomplete removal of triethylamine.2. Formation of side products.	1. Ensure the 1 M HCl wash is performed effectively during workup.2. Re-evaluate reaction conditions (lower temperature, shorter time) to minimize side reactions.

References

- PROCEDURE OF ASYMMETRIC TRANSFER HYDROGENATION USING RUTHENIUM COMPLEX. Takasago Fine Chemicals Division. [\[Link\]](#)
- Transfer hydrogenation. Wikipedia. [\[Link\]](#)
- Asymmetric Hydrogen Atom Transfer. National Center for Biotechnology Information (PMC). [\[Link\]](#)
- Aqueous-phase asymmetric transfer hydrogenation of ketones – a greener approach to chiral alcohols. University of Liverpool. [\[Link\]](#)

- Mechanistic Aspects of Using Formate as a Hydrogen Donor in Aqueous Transfer Hydrogenation. ACS Catalysis. [\[Link\]](#)
- Exploring Hydrogen Sources in Catalytic Transfer Hydrogenation: A Review of Unsaturated Compound Reduction. National Center for Biotechnology Information (PMC). [\[Link\]](#)
- The Noyori Asymmetric Hydrogenation Reaction. Andrew G Myers Research Group, Harvard University. [\[Link\]](#)
- Process for the preparation of formic acid.
- Noyori Hydrogenation. NROChemistry. [\[Link\]](#)
- Enantioselective Transfer Hydrogenation of α -Methoxyimino- β -keto Esters. The Journal of Organic Chemistry. [\[Link\]](#)
- Noyori Hydrogenation. YouTube. [\[Link\]](#)
- An Unexpected Directing Effect in the Asymmetric Transfer Hydrogenation of α,α -Disubstituted Ketones. Organic Letters. [\[Link\]](#)
- A recyclable catalyst for asymmetric transfer hydrogenation with a formic acid-triethylamine mixture in ionic liquid. PubMed. [\[Link\]](#)
- Dynamic Kinetic Resolution of α -Keto Esters via Asymmetric Transfer Hydrogenation. National Center for Biotechnology Information (PMC). [\[Link\]](#)
- Exploring Hydrogen Sources in Catalytic Transfer Hydrogenation: A Review of Unsaturated Compound Reduction. ResearchGate. [\[Link\]](#)
- Dynamic Kinetic Resolution of α -Keto Esters via Asymmetric Transfer Hydrogenation. National Institutes of Health. [\[Link\]](#)
- Enantiomeric separation of hydroxy and hydroperoxy eicosanoids by chiral column chromatography. PubMed. [\[Link\]](#)
- A recyclable catalyst for asymmetric transfer hydrogenation with a formic acid–triethylamine mixture in ionic liquid. Royal Society of Chemistry. [\[Link\]](#)

- Asymmetric Transfer Hydrogenation of α -Keto Amides; Highly Enantioselective Formation of Malic Acid Diamides and α -Hydroxyamides. PubMed. [[Link](#)]
- Ru-TsDPEN catalysts and derivatives in asymmetric transfer hydrogenation reactions. Wiley Online Library. [[Link](#)]
- Ether-tethered Ru(ii)/TsDPEN complexes; synthesis and applications to asymmetric transfer hydrogenation. Royal Society of Chemistry. [[Link](#)]
- Ru-Tethered (R,R)-TsDPEN with DMAB as an efficient catalytic system for high enantioselective one-pot synthesis of chiral β -aminol via asymmetric transfer hydrogenation. Royal Society of Chemistry. [[Link](#)]
- Synthesis of Ru@PCP-TsDPEN catalyst. ResearchGate. [[Link](#)]
- Preparation and Characterization of Ru-Based Catalyst for Power to Gas Applications. MDPI. [[Link](#)]
- Catalytic Asymmetric Transfer Hydrogenation of β,γ -Unsaturated α -Diketones. Journal of the American Chemical Society. [[Link](#)]
- A Strategy for Developing HPLC Methods for Chiral Drugs. LCGC International. [[Link](#)]
- Chiral HPLC Separations. Phenomenex. [[Link](#)]
- Determination of the Content of α -Hydroxy Acids in Cosmetics by HPLC. Atlantis Press. [[Link](#)]
- Chiral HPLC separation: strategy and approaches. Chiralpedia. [[Link](#)]

Need Custom Synthesis?

BenchChem offers custom synthesis for rare earth carbides and specific isotopic labeling.

Email: info@benchchem.com or [Request Quote Online](#).

Sources

- [1. pcliv.ac.uk](http://pcliv.ac.uk) [pcliv.ac.uk]
- [2. Transfer hydrogenation - Wikipedia](https://en.wikipedia.org) [en.wikipedia.org]
- [3. researchgate.net](https://researchgate.net) [researchgate.net]
- [4. pubs.acs.org](https://pubs.acs.org) [pubs.acs.org]
- [5. Exploring Hydrogen Sources in Catalytic Transfer Hydrogenation: A Review of Unsaturated Compound Reduction - PMC](https://pubmed.ncbi.nlm.nih.gov) [[pmc.ncbi.nlm.nih.gov](https://pubmed.ncbi.nlm.nih.gov)]
- [6. pubs.acs.org](https://pubs.acs.org) [pubs.acs.org]
- [7. assets.takasago.com](https://assets.takasago.com) [assets.takasago.com]
- [8. Dynamic Kinetic Resolution of \$\alpha\$ -Keto Esters via Asymmetric Transfer Hydrogenation - PMC](https://pubmed.ncbi.nlm.nih.gov) [[pmc.ncbi.nlm.nih.gov](https://pubmed.ncbi.nlm.nih.gov)]
- [9. pubs.acs.org](https://pubs.acs.org) [pubs.acs.org]
- [10. Dynamic Kinetic Resolution of \$\alpha\$ -Keto Esters via Asymmetric Transfer Hydrogenation - PMC](https://pubmed.ncbi.nlm.nih.gov) [[pmc.ncbi.nlm.nih.gov](https://pubmed.ncbi.nlm.nih.gov)]
- [11. Enantiomeric separation of hydroxy and hydroperoxy eicosanoids by chiral column chromatography - PubMed](https://pubmed.ncbi.nlm.nih.gov) [pubmed.ncbi.nlm.nih.gov]
- [12. chromatographyonline.com](https://chromatographyonline.com) [chromatographyonline.com]
- [13. phx.phenomenex.com](https://phx.phenomenex.com) [phx.phenomenex.com]
- [14. Chiral HPLC separation: strategy and approaches – Chiralpedia](https://chiralpedia.com) [chiralpedia.com]
- To cite this document: BenchChem. [Application Note: Asymmetric Transfer Hydrogenation of α -Keto Esters]. BenchChem, [2026]. [Online PDF]. Available at: [<https://www.benchchem.com/product/b2504192/docs#application-note-asymmetric-transfer-hydrogenation-of-keto-esters>]

Disclaimer & Data Validity:

The information provided in this document is for Research Use Only (RUO) and is strictly not intended for diagnostic or therapeutic procedures. While BenchChem strives to provide accurate protocols, we make no warranties, express or implied, regarding the fitness of this product for every specific experimental setup.

Technical Support: The protocols provided are for reference purposes. Unsure if this reagent suits your experiment?

Need Industrial/Bulk Grade? [Request Custom Synthesis Quote](#)

BenchChem

Our mission is to be the trusted global source of essential and advanced chemicals, empowering scientists and researchers to drive progress in science and industry.

Contact

Address: 3281 E Guasti Rd
Ontario, CA 91761, United States
Phone: (601) 213-4426
Email: info@benchchem.com

[Contact our Ph.D. Support Team for a compatibility check](#)