

Technical Support Center: Optimization of Reaction Conditions for Aminophenol Alkylation

Author: BenchChem Technical Support Team. **Date:** April 2026

Compound of Interest

Compound Name: 4-(Cyclobutylmethylamino)phenol

CAS No.: 1510020-28-6

Cat. No.: B2502041

[Get Quote](#)

Prepared by: Gemini, Senior Application Scientist

Welcome to the technical support center for aminophenol alkylation. This guide is designed for researchers, scientists, and drug development professionals to navigate the complexities of this crucial synthetic transformation. Aminophenols are ambident nucleophiles, possessing two reactive sites: the amino (-NH₂) group and the hydroxyl (-OH) group. This duality presents a significant challenge, as direct alkylation often yields a mixture of N-alkylated, O-alkylated, and N,O-dialkylated products, complicating purification and reducing yields.^[1]

This document provides field-proven insights and troubleshooting strategies in a direct question-and-answer format to help you achieve high selectivity and yield in your experiments.

Diagram: The Core Challenge of Aminophenol Alkylation

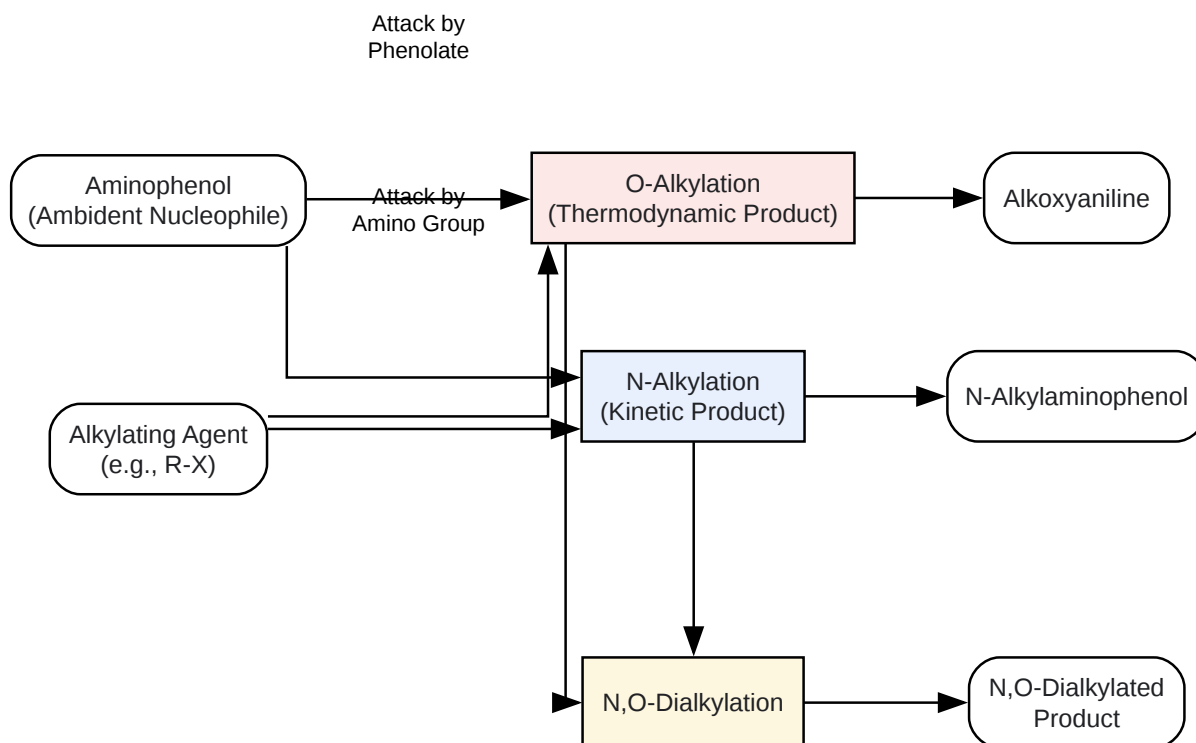

[Click to download full resolution via product page](#)

Caption: Competing N- vs. O-alkylation pathways for aminophenols.

Frequently Asked Questions (FAQs)

Q1: Why is selective alkylation of aminophenols so challenging?

A1: The primary challenge lies in the competing nucleophilicity of the amino and hydroxyl groups. The amino group is generally more nucleophilic than the neutral hydroxyl group, leading to preferential N-alkylation under neutral or mildly basic conditions. However, in the presence of a base, the hydroxyl group is deprotonated to form a much more nucleophilic phenolate anion, which can lead to O-alkylation.^[2] The final product distribution is a delicate balance of factors including the pKa of the functional groups, the strength and type of base used, the solvent's properties, and the nature of the alkylating agent.^[3]

Q2: What are the primary strategies for achieving selective N-alkylation?

A2: The most robust and widely used method for selective N-alkylation is reductive amination.^[1] This one-pot reaction involves the initial formation of an imine (Schiff base) by condensing

the aminophenol with an aldehyde or ketone, followed by in-situ reduction of the imine to the desired N-alkylated amine.[1][4][5] This method is highly selective because the imine formation occurs exclusively at the amino group, and the subsequent reduction is specific to the C=N bond. Alternative methods include "Borrowing Hydrogen" catalysis with alcohols and specialized dual copper/photoredox catalysis systems for alkyl halides.[1]

Q3: How can I achieve selective O-alkylation?

A3: Selective O-alkylation typically requires temporarily deactivating the more nucleophilic amino group. The most common strategy involves:

- Protection of the amino group: The amino group is first protected, often by forming an imine with an aldehyde like benzaldehyde.[4][5][6] This is an efficient and inexpensive method.[5] Other protecting groups like acetyl, Boc, or Cbz can be used but may require harsher deprotection conditions.[4][5]
- Alkylation of the hydroxyl group: With the amino group protected, a base (e.g., K_2CO_3 , NaH) and an alkylating agent are used to alkylate the free hydroxyl group.[5]
- Deprotection: The protecting group is then removed, typically by acid hydrolysis, to reveal the amino group and yield the final O-alkylated product (an alkoxyaniline).[4][5]

Q4: How does the choice of base and solvent influence selectivity?

A4: The base and solvent system is critical. For O-alkylation, a strong base (like NaH or K_2CO_3) is needed to deprotonate the phenol to the more nucleophilic phenolate.[5] Aprotic polar solvents like DMF or acetone are often preferred as they solvate the cation of the base without interfering with the nucleophile.[3][5] For N-alkylation via direct alkylation (which is often problematic), milder conditions are used to avoid significant phenolate formation. For reductive amination, a solvent like methanol is ideal as it facilitates both imine formation and is compatible with reducing agents like sodium borohydride ($NaBH_4$).[1][5]

Troubleshooting Guide

Problem 1: My reaction shows low or no conversion of the starting aminophenol.

- Possible Cause: Insufficiently reactive alkylating agent.

- Explanation: The reactivity of alkyl halides follows the trend $I > Br > Cl$. For less reactive agents like alkyl chlorides or secondary halides, more forcing conditions may be needed.
[7]
- Solution: Switch to a more reactive alkylating agent (e.g., from an alkyl bromide to an alkyl iodide). Increase the reaction temperature, but monitor for potential side reactions or degradation.[5]
- Possible Cause: Poor choice of base or solvent.
 - Explanation: For O-alkylation, the base must be strong enough to deprotonate the phenol. The solvent must also adequately dissolve the reactants. In some cases, poor solubility of the base (e.g., K_2CO_3 in acetone) can lead to incomplete reactions.[8]
 - Solution: For O-alkylation, consider a stronger base like NaH in an aprotic solvent like DMF or THF. For reactions with poor solubility, switching to a solvent like DMF or DMSO, or using a phase-transfer catalyst, can improve results.[8][9]
- Possible Cause (Reductive Amination): Incomplete imine formation or inactive reducing agent.
 - Explanation: Imine formation is an equilibrium process.[10] If the equilibrium is not favorable, there will be little intermediate to reduce. Sodium borohydride can also degrade upon improper storage.
 - Solution: Ensure the aldehyde/ketone is reactive and used in at least a 1:1 stoichiometry. Monitor imine formation by TLC or LC-MS before adding the reducing agent.[1] Use a fresh, verified batch of $NaBH_4$.

Problem 2: I'm getting a mixture of N- and O-alkylated products (poor selectivity).

- Possible Cause: Direct alkylation with an alkyl halide.
 - Explanation: This is the most common reason for poor selectivity. Direct alkylation is notoriously difficult to control because both the amino group and the phenolate (if a base is present) can react.[1][4][5]

- Solution: Avoid direct alkylation if selectivity is critical.
 - For N-alkylation, switch to the reductive amination protocol.[1][5]
 - For O-alkylation, use the amino-protection strategy.[4][5]
- Possible Cause: Incorrect reaction conditions.
 - Explanation: Using a strong base with the intention of N-alkylation will inevitably generate the phenolate, leading to O-alkylation as a side product.
 - Solution: Re-evaluate your strategy based on the desired product. The workflow diagram below provides a decision-making process.

Diagram: Troubleshooting Poor Selectivity

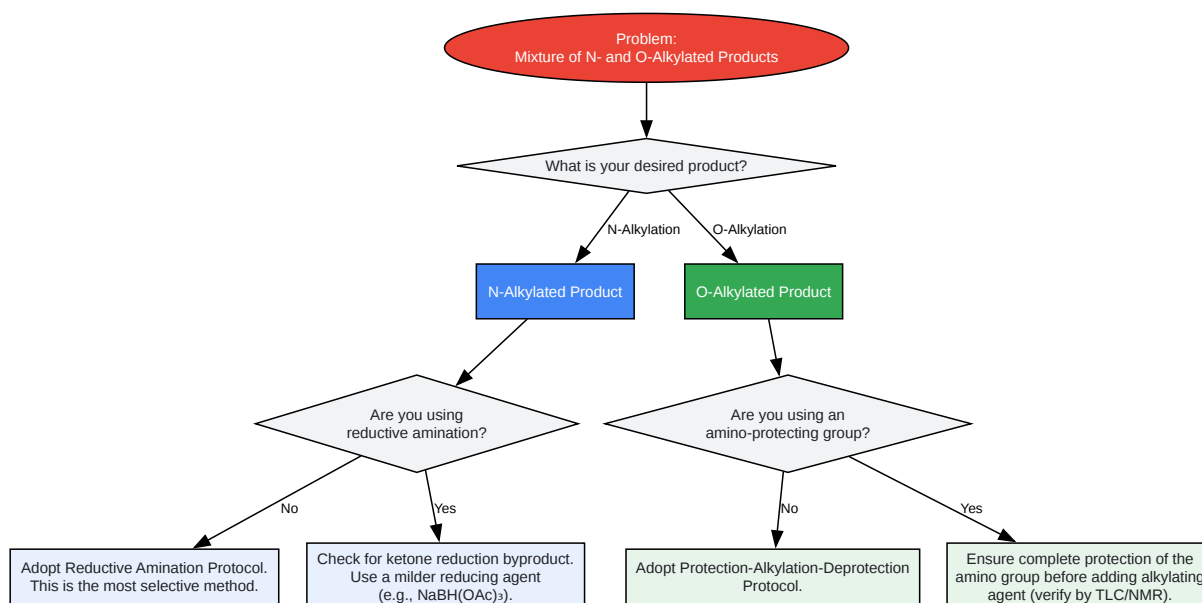

[Click to download full resolution via product page](#)

Caption: Decision workflow for troubleshooting poor alkylation selectivity.

Problem 3: I'm observing significant amounts of di-alkylated product.

- Possible Cause: Over-alkylation with alkyl halides.
 - Explanation: The mono-N-alkylated product is often more nucleophilic than the starting aminophenol, leading to a second alkylation event.^[11] This is a classic problem in amine alkylation.
 - Solution: Use a precise 1.0 equivalent of the alkylating agent. Consider adding the alkylating agent slowly to the reaction mixture to maintain its low concentration. If the problem persists, reductive amination is a superior method as it is not prone to this type of over-alkylation.^{[1][11]}

Problem 4: My reaction mixture is turning dark or forming tar.

- Possible Cause: Oxidation of the aminophenol.
 - Explanation: Aminophenols, particularly 2- and 4-aminophenol, are highly sensitive to air oxidation, which can form colored polymeric impurities.^[12] This can be exacerbated by heat.
 - Solution: Perform the reaction under an inert atmosphere (e.g., nitrogen or argon). Use degassed solvents if possible. When handling the final product, work quickly and store it under an inert atmosphere in a cool, dark place.^[12]

Experimental Protocols

Protocol 1: Selective N-Alkylation via One-Pot Reductive Amination

This protocol is adapted from established high-yield procedures and is broadly applicable.^{[1][5]}

Materials:

- Aminophenol (e.g., 2-aminophenol, 3 mmol, 1.0 equiv)
- Aldehyde (e.g., benzaldehyde, 3 mmol, 1.0 equiv)
- Methanol (MeOH), anhydrous (20 mL)
- Sodium borohydride (NaBH₄, 6 mmol, 2.0 equiv)
- Deionized water, standard lab glassware

Procedure:

- Imine Formation: In a round-bottom flask, dissolve the aminophenol (3 mmol) in methanol (20 mL) with magnetic stirring. To this solution, add the corresponding aldehyde (3 mmol).
- Stir the solution at room temperature for 1 hour. Monitor the formation of the imine intermediate by Thin Layer Chromatography (TLC).
- Reduction: After 1 hour, cool the reaction mixture to 0 °C in an ice bath.
- Carefully add sodium borohydride (6 mmol) to the solution in small portions over 10-15 minutes. Caution: Hydrogen gas evolution will occur.^[1]
- Once the addition is complete, remove the ice bath and allow the reaction to warm to room temperature. Stir for an additional hour.
- Workup and Isolation: Pour the reaction mixture into deionized water (30 mL).^{[1][5]}
- If the product precipitates as a solid, collect it by vacuum filtration.
- If the product is an oil or does not precipitate, extract the aqueous mixture with an appropriate organic solvent (e.g., ethyl acetate, 3 x 20 mL).
- Combine the organic extracts, dry over anhydrous sodium sulfate (Na₂SO₄), filter, and concentrate the solvent under reduced pressure to obtain the crude N-alkylated aminophenol. Purify further by column chromatography or recrystallization as needed.

Protocol 2: Selective O-Alkylation via Benzaldehyde Protection

This protocol outlines the protection-alkylation-deprotection sequence for selective synthesis of alkoxyanilines.^{[4][5]}

Materials:

- Aminophenol (30 mmol, 1.0 equiv)
- Benzaldehyde (30 mmol, 1.0 equiv)
- Methanol (80 mL), Acetone (30 mL)
- Potassium carbonate (K_2CO_3 , 6 mmol, 2.0 equiv relative to imine)
- Alkyl halide (e.g., benzyl bromide, 3 mmol, 1.0 equiv relative to imine)
- 1N Hydrochloric acid (HCl)

Procedure:

- Protection: To a stirred solution of aminophenol (30 mmol) in methanol (80 mL), add benzaldehyde (30 mmol). Stir for 1 hour at room temperature. Remove the solvent under reduced pressure. The resulting crude imine (N-benzylideneaminophenol) can often be purified by recrystallization from ethanol.^[5]
- Alkylation: To a stirred solution of the purified phenylmethyleaminophenol (3 mmol) in acetone (30 mL), add potassium carbonate (6 mmol) and the alkyl halide (3 mmol).
- Reflux the mixture for 20 hours or until TLC analysis shows consumption of the starting material.^[5]
- After cooling, filter the inorganic salts through a pad of Celite and concentrate the filtrate under reduced pressure.
- Deprotection: To the resulting residue, add dichloromethane (10 mL) and 1N HCl (30 mL). Stir the biphasic mixture vigorously for 1 hour to hydrolyze the imine.^[5]

- Separate the layers. Neutralize the aqueous layer carefully with sodium bicarbonate (NaHCO_3) and then extract with dichloromethane (3 x 20 mL).
- Combine the organic extracts, dry over anhydrous Na_2SO_4 , filter, and concentrate under reduced pressure to afford the crude O-alkylated aminophenol. Purify as necessary.

Data Summary Tables

Table 1: Comparison of Primary N-Alkylation Strategies

Method	Alkylating Agent	Selectivity	Key Advantages	Common Issues
Reductive Amination	Aldehydes, Ketones	Excellent for N-alkylation	High yields, one-pot, avoids over-alkylation, wide substrate scope. [1]	Requires control of reducing agent addition; potential for ketone reduction side product. [10]
Direct Alkylation	Alkyl Halides	Generally Poor	Simple setup.	Prone to mixtures of N-, O-, and di-alkylated products. [1] [5] Often low yielding.
"Borrowing Hydrogen"	Alcohols	Good to Excellent	Atom economical, uses "green" alkylating agents. [1]	Requires specific metal catalysts (e.g., Manganese pincer complexes). [1]

Table 2: Example Yields for Selective N-Alkylation via Reductive Amination[\[1\]](#)[\[5\]](#)

Aminophenol	Aldehyde	Product	Yield (%)
2-Aminophenol	Benzaldehyde	2-(Benzylamino)phenol	98.3
2-Aminophenol	4-Methoxybenzaldehyde	2-((4-Methoxybenzyl)amino)phenol	94.5
4-Aminophenol	Benzaldehyde	4-(Benzylamino)phenol	96.7
2-Aminophenol	4-Chlorobenzaldehyde	2-((4-Chlorobenzyl)amino)phenol	89.1

References

- Chemcess. (2025, September 10). Aminophenol: Properties, Production, Reactions And Uses. [\[Link\]](#)
- Wang, R., & Xu, J. (2010). Selective alkylation of aminophenols. ARKIVOC, 2010(ix), 293-299. [\[Link\]](#)
- Google Patents. (1980). US4231963A - Process for producing aminophenol ether.
- ResearchGate. (n.d.). Scheme 1. Selective alkylation of the hydroxyl group of aminophenols. [\[Link\]](#)
- ResearchGate. (n.d.). Selective alkylation of hydroxyl group of aminophenols | Download Table. [\[Link\]](#)
- Sridevi, S., et al. (2019). Synthesis of O- and N-alkylated products of 1,2,3,4-tetrahydrobenzo[c][1][13]naphthyridin-5(6H). [\[Link\]](#)
- Master Organic Chemistry. (2017, May 26). Alkylation of Amines (Sucks!). [\[Link\]](#)
- Reddit. (2021, March 17). Difficulties with N-Alkylations using alkyl bromides : r/Chempros. [\[Link\]](#)

Need Custom Synthesis?

BenchChem offers custom synthesis for rare earth carbides and specific isotopic labeling.

Email: info@benchchem.com or [Request Quote Online](#).

Sources

- [1. pdf.benchchem.com](https://pdf.benchchem.com) [pdf.benchchem.com]
- [2. chemcess.com](https://chemcess.com) [chemcess.com]
- [3. Synthesis of O- and N-alkylated products of 1,2,3,4-tetrahydrobenzo\[c\]\[2,7\]naphthyridin-5\(6H\)-one - PMC](#) [[pmc.ncbi.nlm.nih.gov](https://pubmed.ncbi.nlm.nih.gov/)]
- [4. researchgate.net](https://www.researchgate.net) [[researchgate.net](https://www.researchgate.net)]
- [5. quod.lib.umich.edu](https://quod.lib.umich.edu) [quod.lib.umich.edu]
- [6. researchgate.net](https://www.researchgate.net) [[researchgate.net](https://www.researchgate.net)]
- [7. researchgate.net](https://www.researchgate.net) [[researchgate.net](https://www.researchgate.net)]
- [8. reddit.com](https://www.reddit.com) [[reddit.com](https://www.reddit.com)]
- [9. US4231963A - Process for producing aminophenol ether - Google Patents](#) [patents.google.com]
- [10. pdf.benchchem.com](https://pdf.benchchem.com) [pdf.benchchem.com]
- [11. masterorganicchemistry.com](https://www.masterorganicchemistry.com) [[masterorganicchemistry.com](https://www.masterorganicchemistry.com)]
- [12. pdf.benchchem.com](https://pdf.benchchem.com) [pdf.benchchem.com]
- [13. Merging Excited-State Copper Catalysis and Triplet Nitro\(hetero\)arenes for Direct Synthesis of 2-Aminophenol Derivatives - PMC](#) [[pmc.ncbi.nlm.nih.gov](https://pubmed.ncbi.nlm.nih.gov/)]
- To cite this document: BenchChem. [Technical Support Center: Optimization of Reaction Conditions for Aminophenol Alkylation]. BenchChem, [2026]. [Online PDF]. Available at: [<https://www.benchchem.com/product/b2502041/docs#technical-support-center-optimization-of-reaction-conditions-for-aminophenol-alkylation>]

Disclaimer & Data Validity:

The information provided in this document is for Research Use Only (RUO) and is strictly not intended for diagnostic or therapeutic procedures. While BenchChem strives to provide

accurate protocols, we make no warranties, express or implied, regarding the fitness of this product for every specific experimental setup.

Technical Support: The protocols provided are for reference purposes. Unsure if this reagent suits your experiment?

Need Industrial/Bulk Grade? [Request Custom Synthesis Quote](#)

BenchChem

Our mission is to be the trusted global source of essential and advanced chemicals, empowering scientists and researchers to drive progress in science and industry.

Contact

Address: 3281 E Guasti Rd

Ontario, CA 91761, United States

Phone: (601) 213-4426

Email: info@benchchem.com

[Contact our Ph.D. Support Team for a compatibility check](#)