

Technical Guide: Structural & Functional Divergence of Triazolopyridine Amines[1]

Author: BenchChem Technical Support Team. **Date:** April 2026

Compound of Interest

Compound Name: *[1,2,4]Triazolo[4,3-a]pyridin-7-amine*

CAS No.: *1082448-58-5; 1379186-04-5*

Cat. No.: *B2502748*

[Get Quote](#)

Part 1: Executive Summary

In medicinal chemistry, the

triazolo

pyridine scaffold serves as a bioisostere for quinoline or indole, offering unique hydrogen-bonding vectors and solubility profiles. The distinction between the 3-amine and 7-amine isomers is not merely positional; it represents a fundamental divergence in electronic character, chemical stability, and synthetic accessibility.

- The 3-Amine: A "guanidine-like" exocyclic amine prone to Dimroth rearrangement under basic conditions. It typically functions as a primary interaction point (hinge binder) in kinase inhibitors.
- The 7-Amine: An "aniline-like" amine located on the pyridine ring. It is chemically stable against rearrangement and often serves as a vector for solubilizing groups or extending into solvent-exposed pockets.

Part 2: Structural Anatomy & Numbering

Precise nomenclature is critical for this fused bicyclic system. The numbering initiates at the triazole ring and proceeds through the bridgehead.

- Scaffold:

Triazolo

pyridine[1][2][3][4][5][6][7]

- Bridgehead Nitrogen: Position 4 ()
- 3-Amine: Attached to the 5-membered triazole ring ().
- 7-Amine: Attached to the 6-membered pyridine ring (), para to the bridgehead nitrogen.

Structural Comparison Diagram

The following Graphviz diagram illustrates the numbering and electronic flow.

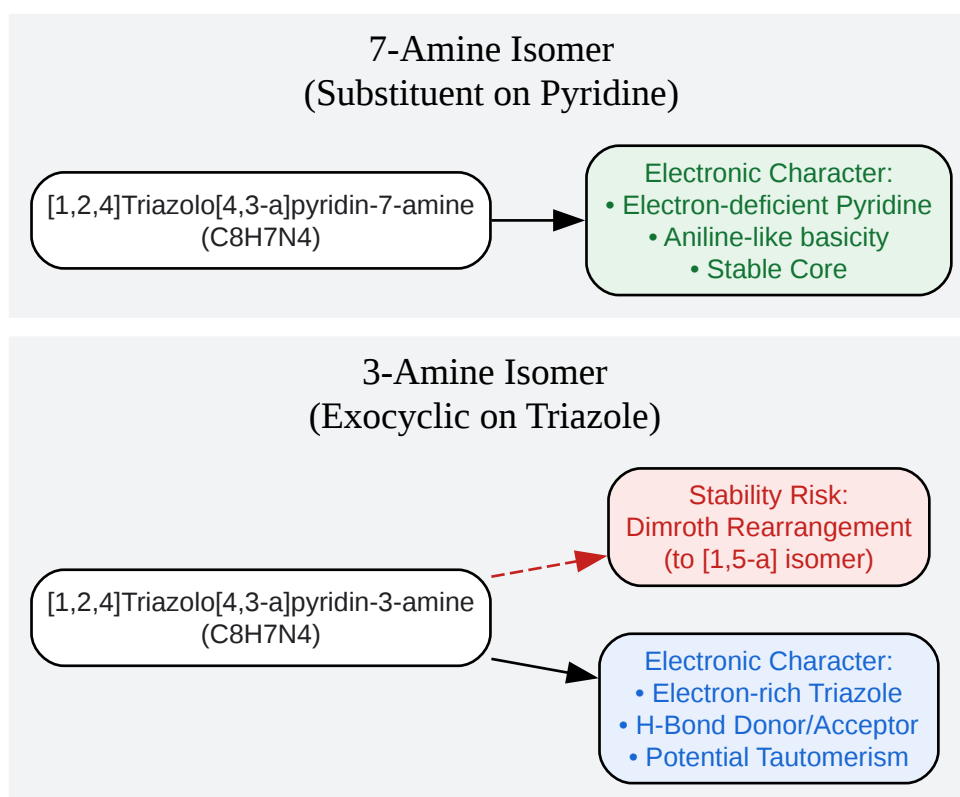

[Click to download full resolution via product page](#)

Figure 1: Structural and property divergence between the 3-amine and 7-amine isomers.

Part 3: Synthetic Methodologies

The synthesis of these two isomers requires completely different retrosynthetic disconnections.

Protocol A: Synthesis of the 3-Amine

The 3-amine is synthesized via the oxidative cyclization of 2-hydrazinopyridine with cyanogen bromide (CNBr). This is a high-yielding reaction but requires handling toxic cyanogen sources.

Reagents:

- 2-Hydrazinopyridine (Starting Material)[1][2]
- Cyanogen Bromide (CNBr)
- Solvent: Ethanol or Acetonitrile/Water[8]

- Base:

(for neutralization)

Step-by-Step Workflow:

- Dissolution: Dissolve 2-hydrazinopyridine (1.0 eq) in ethanol at .
- Cyclization: Add CNBr (1.1 eq) portion-wise (Exothermic!). Stir at ambient temperature for 2–4 hours.
- Precipitation: The hydrobromide salt of the product often precipitates.
- Neutralization: Treat the solid with aqueous saturated to liberate the free base.
- Purification: Recrystallize from ethanol/water.

Protocol B: Synthesis of the 7-Amine

The 7-amine cannot be easily installed via electrophilic substitution because the pyridine ring is deactivated. The most reliable route involves a "Pre-functionalized Cyclization" strategy, starting with a 4-substituted pyridine.

Reagents:

- 2-Chloro-4-nitropyridine (Precursor)
- Hydrazine Hydrate ()
- Triethyl orthoformate (TEOF) or Formic Acid
- Reduction Agent:

or

Step-by-Step Workflow:

- **Hydrazine Displacement:** React 2-chloro-4-nitropyridine with hydrazine hydrate in refluxing ethanol for 3 hours to yield 2-hydrazino-4-nitropyridine.
- **Ring Closure:** Reflux the hydrazine intermediate in excess triethyl orthoformate (TEOF) for 6–12 hours. This forms the triazolo pyridine core with a nitro group at position 7.
- **Reduction:** Dissolve the nitro-intermediate in methanol. Add catalyst and stir under atmosphere (balloon pressure) for 12 hours.
- **Isolation:** Filter through Celite and concentrate to yield the 7-amine.

Synthetic Pathway Diagram[1][2]

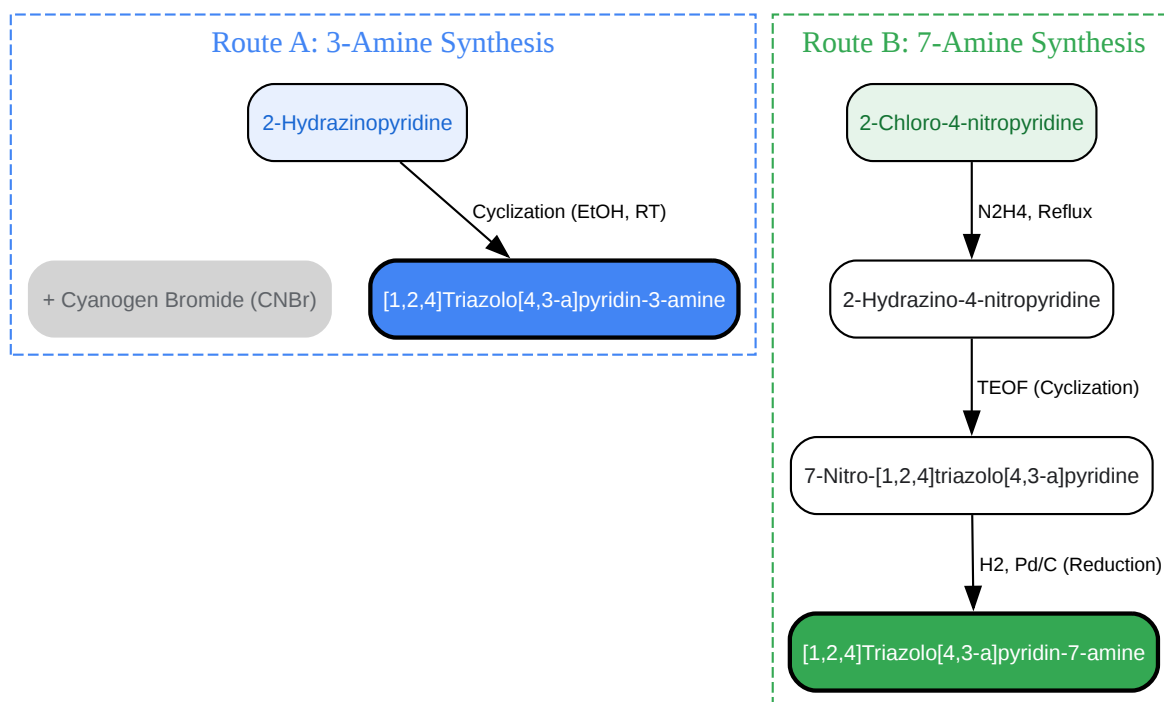

[Click to download full resolution via product page](#)

Figure 2: Comparative synthetic pathways for 3-amine and 7-amine isomers.

Part 4: Physicochemical & Stability Divergence[1] The Dimroth Rearrangement (Critical Stability Factor)

The most significant technical difference is the susceptibility of the 3-amine to the Dimroth rearrangement.

- Mechanism: Under basic or thermal conditions, the electron-deficient pyrimidine/pyridine ring is attacked by hydroxide (or water), leading to ring opening and re-closure to the thermodynamically more stable

isomer.

- **3-Amine:** Highly susceptible. The 3-amino group acts as an internal nucleophile during the intermediate state, or simply exists on the ring that rearranges. The product is 2-amino-triazolo pyridine.
- **7-Amine:** The amino group is on the pyridine ring (spectator). It does not induce rearrangement, though the scaffold itself can still rearrange if subjected to harsh conditions. The 7-amino group (electron-donating) actually stabilizes the kinetic isomer by reducing the electrophilicity of the pyridine ring, making it less prone to nucleophilic attack than the unsubstituted parent.

Basicity and Electronic Profile (pKa)

The two amines exhibit distinct pKa values due to their local electronic environments.

Feature	3-Amine	7-Amine
Local Environment	Exocyclic on 5-membered triazole ring.[5]	Exocyclic on 6-membered pyridine ring.
Resonance	Lone pair delocalized into the triazole -system.	Lone pair delocalized into pyridine ring (para to bridgehead N).
Basicity (Predicted)	More Basic (pKa 4.5–5.5). Resembles a deactivated guanidine.	Less Basic (pKa 2.5–3.5). Resembles a deactivated aniline.
H-Bonding	Strong Donor (NH ₂) & Acceptor (N ₂ of triazole).	Strong Donor (NH ₂); Weak Acceptor.

Part 5: References

- Synthesis of Triazolopyridines:
 - Title: Efficient Synthesis and X-ray Structure of

Triazolo

pyridines via Oxidative Cyclization Using N-Chlorosuccinimide.

- Source: MDPI, Molbank 2021.
- URL:[\[Link\]](#)^[5]
- Dimroth Rearrangement Mechanism:
 - Title: The Dimroth Rearrangement in the Synthesis of Condensed Pyrimidines.^[3]^[9]
 - Source: Chemistry of Heterocyclic Compounds, 2021.^[10]^[3]^[11]
 - URL:[\[Link\]](#)
- Structural Properties of 3-Amine:
 - Title: The Structural and Optical Properties of
Triazolo
pyridin-3-amine.^[4]^[12]^[13]
 - Source: Molecules, 2022.^[10]^[12]^[13]
 - URL:[\[Link\]](#)
- General Reactivity of Triazolo-Pyridine Scaffold:
 - Title: Synthesis of
triazolo
pyridines (Organic Chemistry Portal).
 - Source: Organic Chemistry Portal.
 - URL:[\[Link\]](#)

Need Custom Synthesis?

BenchChem offers custom synthesis for rare earth carbides and specific isotopic labeling.

Email: info@benchchem.com or [Request Quote Online](#).

Sources

- [1. researchgate.net \[researchgate.net\]](#)
- [2. mdpi.com \[mdpi.com\]](#)
- [3. The Dimroth Rearrangement in the Synthesis of Condensed Pyrimidines – Structural Analogs of Antiviral Compounds - PMC \[pmc.ncbi.nlm.nih.gov\]](#)
- [4. researchgate.net \[researchgate.net\]](#)
- [5. Synthesis of pyrido\[2,1-c\]\[1,2,4\]triazine,1,2,4 triazolo\[4,3-a\] pyridine and 2-\(substituted-pyrazolyl\)nicotinonitrile and their effect on Biomphalaria alexandrina snail enzymes - PubMed \[pubmed.ncbi.nlm.nih.gov\]](#)
- [6. The Structural and Optical Properties of 1,2,4-Triazolo\[4,3-a\]pyridine-3-amine - PMC \[pmc.ncbi.nlm.nih.gov\]](#)
- [7. researchgate.net \[researchgate.net\]](#)
- [8. researchgate.net \[researchgate.net\]](#)
- [9. eurekaselect.com \[eurekaselect.com\]](#)
- [10. alfa-chemistry.com \[alfa-chemistry.com\]](#)
- [11. starchemistry888.com \[starchemistry888.com\]](#)
- [12. The Structural and Optical Properties of 1,2,4-Triazolo\[4,3- a\]pyridine-3-amine - PubMed \[pubmed.ncbi.nlm.nih.gov\]](#)
- [13. mdpi.com \[mdpi.com\]](#)
- To cite this document: BenchChem. [Technical Guide: Structural & Functional Divergence of Triazolopyridine Amines[1]]. BenchChem, [2026]. [Online PDF]. Available at: [\[https://www.benchchem.com/product/b2502748/docs#technical-guide-structural-functional-divergence-of-triazolopyridine-amines-1\]](https://www.benchchem.com/product/b2502748/docs#technical-guide-structural-functional-divergence-of-triazolopyridine-amines-1)

Disclaimer & Data Validity:

The information provided in this document is for Research Use Only (RUO) and is strictly not intended for diagnostic or therapeutic procedures. While BenchChem strives to provide accurate protocols, we make no warranties, express or implied, regarding the fitness of this product for every specific experimental setup.

Technical Support: The protocols provided are for reference purposes. Unsure if this reagent suits your experiment?

Need Industrial/Bulk Grade? [Request Custom Synthesis Quote](#)

BenchChem

Our mission is to be the trusted global source of essential and advanced chemicals, empowering scientists and researchers to drive progress in science and industry.

Contact

Address: 3281 E Guasti Rd
Ontario, CA 91761, United States
Phone: (601) 213-4426
Email: info@benchchem.com

[Contact our Ph.D. Support Team for a compatibility check](#)