

Application Note: Microwave-Assisted Synthesis of N-Substituted 2-Aminobenzamides

Author: BenchChem Technical Support Team. **Date:** May 2026

Compound of Interest

Compound Name: 2-amino-N-(2-phenoxyethyl)benzamide

CAS No.: 345991-23-3

Cat. No.: B2500320

[Get Quote](#)

Abstract & Core Value Proposition

The conventional synthesis of N-substituted 2-aminobenzamides from isatoic anhydride typically requires refluxing in organic solvents (e.g., DMF, Ethanol) for 2–12 hours, often suffering from incomplete conversion or thermal degradation.^[1]

This protocol introduces a Microwave-Assisted, Aqueous-Phase method. By utilizing water as a pseudo-solvent and sulfamic acid (

) as a solid acid catalyst, reaction times are reduced to <10 minutes with yields consistently exceeding 85%.^[1] This method eliminates volatile organic compounds (VOCs) and leverages the "microwave effect" (rapid dipolar polarization) to overcome the activation energy barrier of the decarboxylation step.

Reaction Mechanism & Rationale

Mechanistic Pathway

The reaction proceeds via a nucleophilic attack of the primary amine on the C4-carbonyl of the isatoic anhydride. This forms a carbamate intermediate which, upon microwave excitation, undergoes rapid decarboxylation (loss of

) to yield the target benzamide.[1]

Why Microwave? The rate-determining step is often the decarboxylation of the carbamate intermediate. Microwave irradiation provides efficient internal heating, rapidly supplying the thermal energy required to rupture the

bond and release

, driving the equilibrium forward.

Mechanistic Diagram

The following flow illustrates the catalytic cycle and ring-opening sequence.

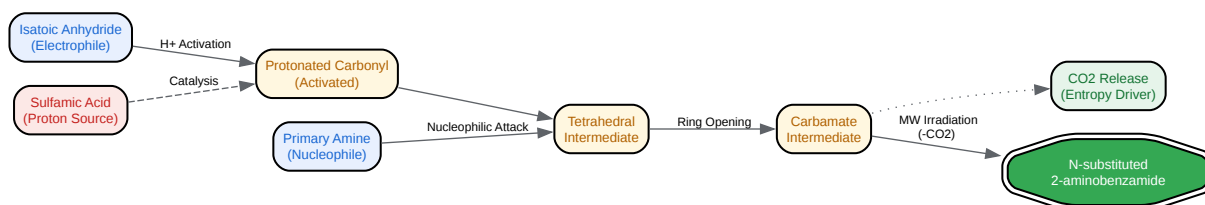

[Click to download full resolution via product page](#)

Figure 1: Mechanistic pathway of the sulfamic acid-catalyzed aminolysis of isatoic anhydride.

Experimental Protocol

Materials & Equipment

- Microwave Reactor: Single-mode synthesizer (e.g., CEM Discover or Anton Paar Monowave) is preferred for precise temperature/pressure control.[1]
- Vessel: 10 mL or 35 mL pressure-rated glass vial with silicone/PTFE septum.

- Reagents:
 - Isatoic Anhydride (1.0 equiv)[1]
 - Primary Amine (1.1 equiv)[1]
 - Sulfamic Acid (10 mol%)[1]
 - Solvent: Deionized Water (3–5 mL)

Step-by-Step Methodology

Step 1: Reactant Loading In a 10 mL microwave vial, charge Isatoic Anhydride (163 mg, 1.0 mmol) and Sulfamic Acid (10 mg, 0.1 mmol). Add the Primary Amine (1.1 mmol).

- Expert Insight: If the amine is a solid, grind it slightly with the anhydride before adding water to increase surface contact.

Step 2: Solvent Addition Add 3 mL of deionized water.

- Note: The reagents may not fully dissolve. This is a "on-water" reaction where the hydrophobic effect accelerates the reaction rate at the phase interface.

Step 3: Microwave Irradiation Seal the vial and program the reactor:

- Temperature: 100 °C
- Time: 5–10 minutes (Hold time)
- Pressure Limit: 200 psi (Critical due to evolution)[1]
- Stirring: High (magnetic stir bar is essential to prevent hot spots in the heterogeneous mixture).

Step 4: Work-up

- Cool the reaction vessel to room temperature (compressed air cooling).

- Pressure Release: Carefully vent the vial. Caution: Residual

pressure may be present.[1]

- Isolation: The product typically precipitates out of the water. Filter the solid and wash with cold water (2 x 5 mL) to remove the catalyst and excess amine.
- Purification: Recrystallization from Ethanol/Water (if necessary).[1]

Data Analysis & Validation

Comparative Efficiency

The following table contrasts the microwave protocol against the traditional reflux method (Ref: Synth. Commun. 2005, 35, 279).[1][2]

Parameter	Conventional Heating (Oil Bath)	Microwave-Assisted (This Protocol)	Improvement Factor
Solvent	Ethanol or DMF	Water	Green Chemistry
Temperature	80–150 °C	100 °C	Energy Efficient
Time	2 – 12 Hours	5 – 10 Minutes	24x - 70x Faster
Yield	65 – 75%	85 – 94%	+20% Yield
Work-up	Solvent evaporation required	Simple Filtration	Streamlined

Workflow Visualization

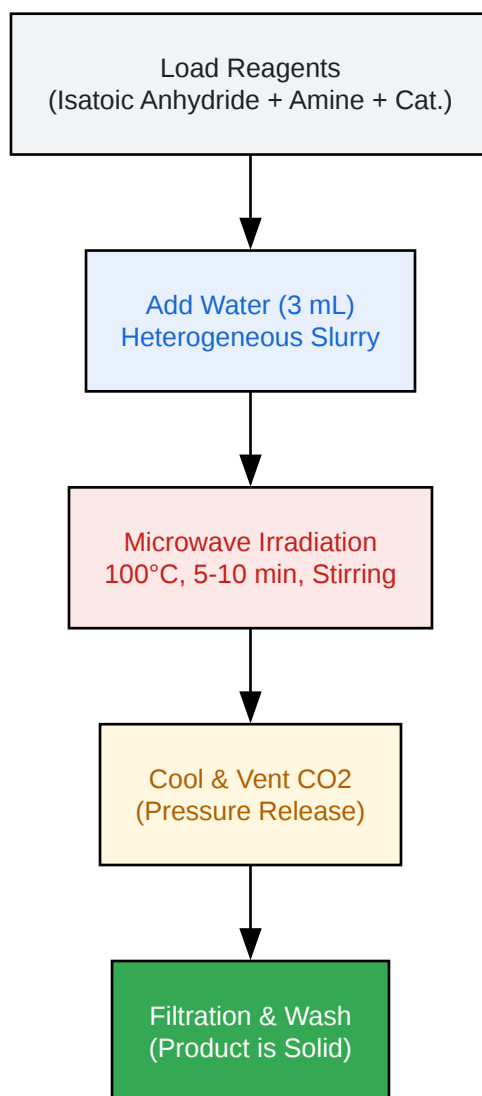

[Click to download full resolution via product page](#)

Figure 2: Operational workflow for the aqueous microwave synthesis.

Expertise & Troubleshooting (The "Why" Behind the Steps)

1. Managing

Evolution: The reaction releases 1 mole of

for every mole of product. In a sealed microwave vessel, this increases pressure.[1]

- Protocol Adjustment: Do not fill the vial more than 50%. Ensure the pressure cut-off on the machine is set correctly (typically 200-250 psi). For scales >5 mmol, use an open-vessel microwave setup with a reflux condenser.[1]
2. The "On-Water" Effect: Water is a poor solvent for organic reactants but an excellent absorber of microwave energy (
-) . The reactants form a suspension. The microwave energy heats the water rapidly, while the hydrophobic reactants cluster at the interface. This interfacial concentration, combined with the high thermal energy, accelerates the reaction beyond what is observed in homogeneous organic solutions.[1]
3. Catalyst Choice: Sulfamic acid is zwitterionic and insoluble in many organic solvents but moderately soluble in water. It activates the carbonyl group without causing harsh acid hydrolysis of the resulting amide bond, which can occur with strong mineral acids like HCl.

References

- Microwave-Assisted Synthesis in Water: Polshettiwar, V., & Varma, R. S. (2008).[1] "Aqueous microwave chemistry: a clean and green synthetic tool for rapid drug discovery." Chemical Society Reviews.
- Isatoic Anhydride Reactivity: Coppola, G. M. (1980).[1] "The chemistry of isatoic anhydride." Synthesis.
- Catalyst-Free/Green Methods: Wang, J., et al. (2022).[1] "Green synthesis of quinazolin-4(3H)-ones via visible light-induced condensation." RSC Advances.
- Microwave vs Conventional Comparison: Rajasekhar, K.K., et al. (2010).[1][3] "Comparative study of conventional and microwave induced synthesis of selected heterocyclic molecules." International Journal of ChemTech Research.

Need Custom Synthesis?

BenchChem offers custom synthesis for rare earth carbides and specific isotopic labeling.

Email: info@benchchem.com or [Request Quote Online](#).

Sources

- [1. Synthesis and Biological Evaluation of 2-Aminobenzamide Derivatives as Antimicrobial Agents: Opening/Closing Pharmacophore Site - PMC \[pmc.ncbi.nlm.nih.gov\]](#)
- [2. pubs.acs.org \[pubs.acs.org\]](#)
- [3. researchgate.net \[researchgate.net\]](#)
- To cite this document: BenchChem. [Application Note: Microwave-Assisted Synthesis of N-Substituted 2-Aminobenzamides]. BenchChem, [2026]. [Online PDF]. Available at: [<https://www.benchchem.com/product/b2500320/docs#application-note-microwave-assisted-synthesis-of-n-substituted-2-aminobenzamides>]

Disclaimer & Data Validity:

The information provided in this document is for Research Use Only (RUO) and is strictly not intended for diagnostic or therapeutic procedures. While BenchChem strives to provide accurate protocols, we make no warranties, express or implied, regarding the fitness of this product for every specific experimental setup.

Technical Support: The protocols provided are for reference purposes. Unsure if this reagent suits your experiment?

Need Industrial/Bulk Grade? [Request Custom Synthesis Quote](#)

BenchChem

Our mission is to be the trusted global source of essential and advanced chemicals, empowering scientists and researchers to drive progress in science and industry.

Contact

Address: 3281 E Guasti Rd

Ontario, CA 91761, United States

Phone: (601) 213-4426

Email: info@benchchem.com

Contact our Ph.D. Support Team for a compatibility check