

# Application Note: Scalable Synthesis of 1-(Pyridin-2-yl)cyclohexanecarbonitrile

**Author:** BenchChem Technical Support Team. **Date:** May 2026

## Compound of Interest

Compound Name:	1-(Pyridin-2-yl)cyclohexanecarbonitrile
CAS No.:	204067-32-3
Cat. No.:	B2497868

[Get Quote](#)

## Executive Summary

This application note details the optimized protocol for synthesizing **1-(pyridin-2-yl)cyclohexanecarbonitrile** from 2-pyridylacetonitrile. This transformation constructs a quaternary carbon center via a double alkylation (cycloalkylation) using 1,5-dibromopentane.

While traditional methods employ hazardous anhydrous bases (e.g., NaH, NaNH<sub>2</sub>), this guide prioritizes a Phase-Transfer Catalysis (PTC) approach. The PTC method offers superior scalability, safety, and operational simplicity, utilizing 50% aqueous sodium hydroxide and a quaternary ammonium catalyst. This scaffold is a critical pharmacophore in the synthesis of anticholinergics, antihistamines, and antiarrhythmic agents (analogous to Disopyramide precursors).

## Reaction Mechanics & Strategic Analysis

### The Challenge of Quaternary Carbon Formation

Synthesizing gem-disubstituted cycloalkanes requires overcoming significant steric hindrance. The

-protons of 2-pyridylacetonitrile are acidic (

in DMSO), significantly more so than phenylacetonitrile (

), due to the electron-withdrawing inductive effect and resonance stabilization provided by the pyridine ring nitrogen.

## Mechanism of Action

The reaction proceeds via a stepwise dialkylation mechanism:

- **Interfacial Deprotonation:** The phase-transfer catalyst ( $Q^+X^-$ ) transports hydroxide ions from the aqueous phase to the organic interface, deprotonating the nitrile to form a carbanion.
- **First Alkylation:** The carbanion attacks 1,5-dibromopentane via  
.
- **Intramolecular Cyclization:** A second deprotonation occurs, followed by a rapid intramolecular  
attack to close the cyclohexane ring.

## Reaction Pathway Visualization

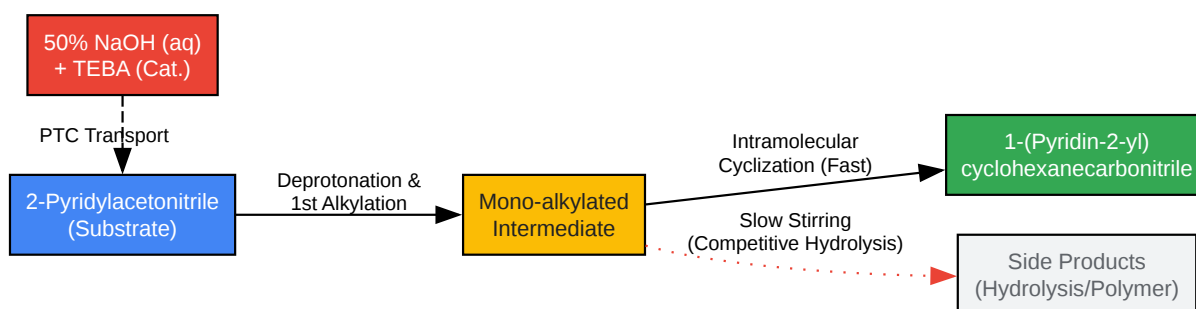

[Click to download full resolution via product page](#)

Figure 1: Mechanistic pathway highlighting the critical intramolecular cyclization step.

## Experimental Protocol

### Reagents & Materials

Component	Role	Equiv.	CAS No.[1][2] [3][4][5]	Notes
2-Pyridylacetonitrile	Substrate	1.0	2739-97-1	Commercial grade, >98%
1,5-Dibromopentane	Electrophile	1.1	111-24-0	Clear liquid; check for yellowing (degradation)
NaOH (50% aq)	Base	4.0	1310-73-2	Prepare fresh or use commercial solution
TEBA	Catalyst	0.05	56-37-1	Benzyltriethylammonium chloride
Toluene	Solvent	N/A	108-88-3	Optional (can run neat)

## Step-by-Step Methodology

### Step 1: Reactor Setup

- Vessel: 3-neck round-bottom flask equipped with a mechanical stirrer (overhead stirring is mandatory for PTC), reflux condenser, and internal thermometer.
- Atmosphere: Flush with Nitrogen ( ) to prevent oxidative degradation, though PTC protects the anion to some extent.

### Step 2: Reagent Charging

- Charge 2-pyridylacetonitrile (1.0 equiv) and 1,5-dibromopentane (1.1 equiv) into the flask.
- Add TEBA (0.05 equiv).

- Optional: Add Toluene (2-3 volumes) if the scale is small (<10g) to ensure good mixing. For larger scales, the neat reagents often suffice.

### Step 3: Initiation (The Exotherm)

- Cool the mixture to 0–5°C using an ice bath.
- Add 50% NaOH (4.0 equiv) dropwise via an addition funnel over 30–60 minutes.
  - Critical Control Point: The reaction is exothermic. Maintain internal temperature during addition.
  - Observation: The mixture will turn from clear/yellow to a deep orange/red (characteristic of the pyridyl-stabilized carbanion).

### Step 4: Reaction Phase

- Once addition is complete, remove the ice bath.
- Allow the reaction to warm to Room Temperature (20–25°C).
- Stir Vigorously (>600 RPM). The rate of reaction is diffusion-controlled; the interface surface area determines the kinetics.
- Monitor by HPLC or GC after 3 hours. (Target conversion >98%).

### Step 5: Workup

- Dilute the reaction mixture with Water (5 volumes) and Toluene (or MTBE).
- Separate the phases. Extract the aqueous layer twice with Toluene.
- Wash combined organics with:
  - Water (
  - )

- 10% HCl (Careful! This extracts the pyridine product into the aqueous phase). See Purification Strategy below.
- Alternative Wash: Wash with Brine to remove catalyst, keep product in organic phase.
- Dry over anhydrous  
and concentrate under reduced pressure.

## Step 6: Purification

- Distillation: The crude oil can be distilled under high vacuum (<1 mmHg).
- Crystallization: If the product solidifies (melting point is often low, ~40-50°C for similar analogs), recrystallize from Isopropanol/Hexane.
- Salt Formation: To isolate high-purity material, dissolve the crude oil in Ethanol and add 1.1 equiv of Oxalic Acid or HCl in ether. The salt precipitates cleanly.

## Process Workflow Diagram

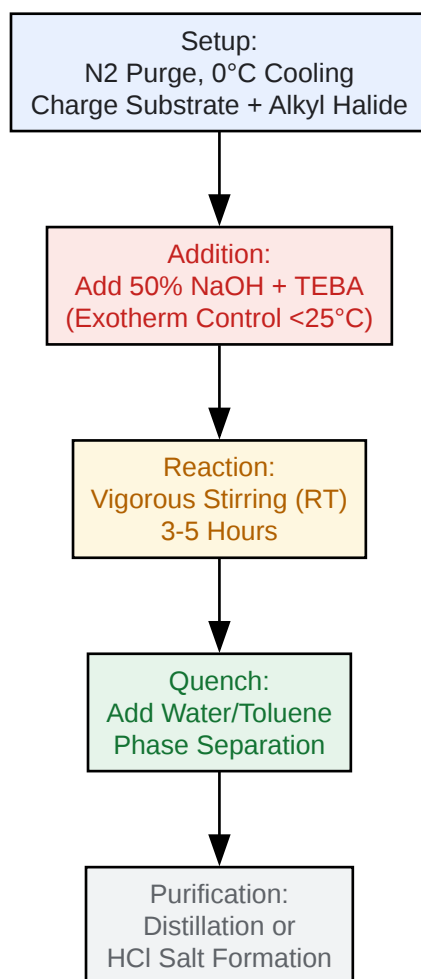

[Click to download full resolution via product page](#)

Figure 2: Operational workflow for the PTC synthesis.

## Analytical Specifications

To ensure the integrity of the synthesized compound, the following analytical parameters should be met:

Test	Method	Acceptance Criteria
Appearance	Visual	Pale yellow oil or low-melting solid
Identification	<sup>1</sup> H-NMR (CDCl <sub>3</sub> )	8.5 (d, 1H, Py), 1.2-2.2 (m, 10H, Cy)
Purity	HPLC (C18, ACN/H <sub>2</sub> O)	> 98.0% Area
Water Content	Karl Fischer	< 0.5%

NMR Diagnostic Signal: Look for the disappearance of the singlet at

~4.0 ppm (the

of the starting acetonitrile) and the appearance of the complex multiplet envelope of the cyclohexane ring (

) protons.

## Troubleshooting & Safety

### Common Issues

- **Low Yield:** Usually due to insufficient stirring speed. The catalyst must transfer between phases efficiently. Increase RPM.
- **Mono-alkylation Impurities:** Caused by insufficient base or stopping the reaction too early. Ensure >4 equiv NaOH is used to drive the second alkylation.
- **Dark/Tar Formation:** Reaction temperature too high. The pyridine ring is electron-deficient and can undergo nucleophilic attack/polymerization at high temperatures. Keep T < 40°C.

### Safety Hazards

- **2-Pyridylacetonitrile:** Toxic by inhalation and skin contact. Handle in a fume hood.
- **Sodium Hydroxide (50%):** Extremely corrosive. Causes severe burns. Wear chemical-resistant gloves and face shield.

- Exotherm: The deprotonation is fast. Accumulation of reagents followed by a sudden "kick" can lead to thermal runaway. Always add base slowly.

## References

- Makosza, M., & Jonczyk, A. (1976). Phase-Transfer Alkylation of Nitriles: 2-Phenylbutyronitrile. *Organic Syntheses*, 55, 91.
- Fleming, F. F., et al. (2015).[6] Isonitrile Alkylations: A Rapid Route to Imidazo[1,5-a]pyridines.[6][7] *Chemical Communications*. (Discusses acidity and alkylation of pyridine derivatives).
- BenchChem. (2025). 2-Phenyl-2-(2-pyridyl)acetonitrile Product Data & Synthesis Analogies.
- Sato, Y., et al. (1997). Synthesis of 1-Arylcyclohexanecarbonitriles via Phase Transfer Catalysis. *Chemical & Pharmaceutical Bulletin*. (General reference for gem-disubstituted cyclohexane synthesis).

### *Need Custom Synthesis?*

*BenchChem offers custom synthesis for rare earth carbides and specific isotopic labeling.*

*Email: [info@benchchem.com](mailto:info@benchchem.com) or [Request Quote Online](#).*

## Sources

- 1. [caymanchem.com](https://caymanchem.com) [[caymanchem.com](https://caymanchem.com)]
- 2. [CAS Common Chemistry](https://commonchemistry.cas.org) [[commonchemistry.cas.org](https://commonchemistry.cas.org)]
- 3. [Cyclohexanecarbonitrile, 1-\(1-piperidiny\)-](https://webbook.nist.gov) [[webbook.nist.gov](https://webbook.nist.gov)]
- 4. [1-Piperidincyclohexanecarbonitrile](https://cymitquimica.com) | [CymitQuimica](https://cymitquimica.com) [[cymitquimica.com](https://cymitquimica.com)]
- 5. [alpha-Phenyl-2-pyridineacetonitrile](https://m.chemicalbook.com) CAS#: 5005-36-7 [[m.chemicalbook.com](https://m.chemicalbook.com)]
- 6. [pubs.rsc.org](https://pubs.rsc.org) [[pubs.rsc.org](https://pubs.rsc.org)]
- 7. [Isonitrile Alkylations: A Rapid Route to Imidazo\[1,5-a\]pyridines](https://pmc.ncbi.nlm.nih.gov) - PMC [[pmc.ncbi.nlm.nih.gov](https://pmc.ncbi.nlm.nih.gov)]
- To cite this document: BenchChem. [Application Note: Scalable Synthesis of 1-(Pyridin-2-yl)cyclohexanecarbonitrile]. BenchChem, [2026]. [Online PDF]. Available at:

[<https://www.benchchem.com/product/b2497868/docs#application-note-scalable-synthesis-of-1-pyridin-2-yl-cyclohexanecarbonitrile>]

**Disclaimer & Data Validity:**

The information provided in this document is for Research Use Only (RUO) and is strictly not intended for diagnostic or therapeutic procedures. While BenchChem strives to provide accurate protocols, we make no warranties, express or implied, regarding the fitness of this product for every specific experimental setup.

**Technical Support:** The protocols provided are for reference purposes. Unsure if this reagent suits your experiment?

**Need Industrial/Bulk Grade?** [Request Custom Synthesis Quote](#)

## BenchChem

Our mission is to be the trusted global source of essential and advanced chemicals, empowering scientists and researchers to drive progress in science and industry.

### Contact

Address: 3281 E Guasti Rd  
Ontario, CA 91761, United States  
Phone: (601) 213-4426  
Email: [info@benchchem.com](mailto:info@benchchem.com)

[Contact our Ph.D. Support Team for a compatibility check](#)