

Comparative Guide: Mass Spectrometry Characterization of 2-Methylpiperidin-3-one HCl

Author: BenchChem Technical Support Team. **Date:** May 2026

Compound of Interest

| | |
|----------------|--|
| Compound Name: | 2-Methylpiperidin-3-one hydrochloride |
| CAS No.: | 1894125-82-6 |
| Cat. No.: | B2468489 |

[Get Quote](#)

Executive Summary

2-Methylpiperidin-3-one HCl is a critical heterocyclic building block, often utilized in the synthesis of alkaloids and pharmaceutical intermediates.[1] Its characterization presents a specific analytical challenge: as a hydrochloride salt, it is polar, non-volatile, and thermally labile, making direct Gas Chromatography (GC) analysis destructive.

This guide compares the two primary mass spectrometry workflows for this compound:

- LC-ESI-MS/MS: The preferred method for intact salt analysis, purity profiling, and high-throughput screening.[1]
- GC-EI-MS: The gold standard for structural elucidation and library matching, requiring a mandatory free-basing pretreatment.[1]

Technical Comparison: LC-ESI vs. GC-EI

The following table summarizes the operational differences when characterizing 2-Methylpiperidin-3-one HCl.

| Feature | Method A: LC-ESI-MS/MS | Method B: GC-EI-MS |
|--------------------|---------------------------------------|--|
| Analyte State | Ionized in solution (Salt compatible) | Neutral gas phase (Requires Free Base) |
| Sample Prep | Minimal (Dilute & Shoot) | Moderate (Neutralization/Extraction) |
| Primary Ion | | |
| Ionization Energy | Soft (~0-5 eV internal) | Hard (70 eV) |
| Structural Detail | Low (Requires CID MS/MS) | High (Fingerprint Fragmentation) |
| Limit of Detection | High Sensitivity (pg range) | Moderate Sensitivity (ng range) |
| Throughput | High (< 5 min/sample) | Low (> 15 min/sample) |

Method A: LC-ESI-MS/MS (Direct Analysis)[1]

Context: Liquid Chromatography coupled with Electrospray Ionization (ESI) is the most robust method for the hydrochloride salt form. It avoids thermal degradation and allows for direct detection of the protonated cation.

Experimental Protocol

- Solvent System: Water/Acetonitrile (95:[1]5) + 0.1% Formic Acid.[1][2]
 - Why Formic Acid? It maintains the protonated state of the secondary amine (pKa ~9-10) and improves ionization efficiency [1].
- Column: C18 Reverse Phase (e.g., Agilent ZORBAX Eclipse Plus, 2.1 x 50mm, 1.8µm).
 - Note: Due to high polarity, retention may be low on standard C18. Consider HILIC columns if retention < 1.0 min.[1]

- Injection: 1-5 μ L of 10 ppm solution.
- MS Parameters: Positive Mode (ESI+). Scan range

50–300.[1]

Spectral Analysis & Fragmentation[2][3][4][5]

- Parent Ion: The spectrum is dominated by the protonated molecular ion
.[3]
 - Observed
: 114.09[1]
- MS/MS Fragmentation (Collision Induced Dissociation - CID):
 - Upon applying collision energy (10-20 eV), the piperidone ring typically undergoes neutral loss of water or carbon monoxide.
 - Fragment 1 (
96): Loss of
(
).[1] Common in cyclic ketones.[1]
 - Fragment 2 (
86): Loss of CO (
). Ring contraction.[1]

Method B: GC-EI-MS (Structural Fingerprinting)[1]

Context: Gas Chromatography with Electron Impact (EI) provides a spectral "fingerprint" that can be matched against NIST libraries.[1] However, direct injection of the HCl salt will damage the GC liner and yield poor peak shapes due to thermal decomposition [2].

Experimental Protocol (Mandatory Free-Basing)

- Neutralization: Dissolve 10 mg of 2-Methylpiperidin-3-one HCl in 1 mL water. Add 1 mL of 1M NaOH (pH > 12).
- Extraction: Add 1 mL Dichloromethane (DCM) or Ethyl Acetate.[1] Vortex for 30 seconds.[1]
- Separation: Collect the organic (bottom) layer.[1] Dry over anhydrous .[1]
- Injection: Inject 1 µL of the organic layer into the GC (Split 10:1).
- GC Parameters: DB-5ms Column. Ramp 50°C to 250°C at 15°C/min.[1]

Spectral Analysis & Fragmentation[2][3][4][5]

- Molecular Ion: The radical cation

is observed, though often weak due to fragmentation.

- Observed

: 113.08[1]

- Characteristic Fragments (70 eV):
 - -Cleavage: The bond adjacent to the amine nitrogen and the carbonyl group is highly labile.
 - 85 (): Loss of the carbonyl group.[1]
 - 98 (): Loss of the methyl group at the C2 position.[1]
 - 42/43: Low mass fragments typical of alkyl amines ().[1]

Visualizing the Analytical Workflow

The following diagram illustrates the decision matrix for selecting the correct method based on the sample state and data requirements.

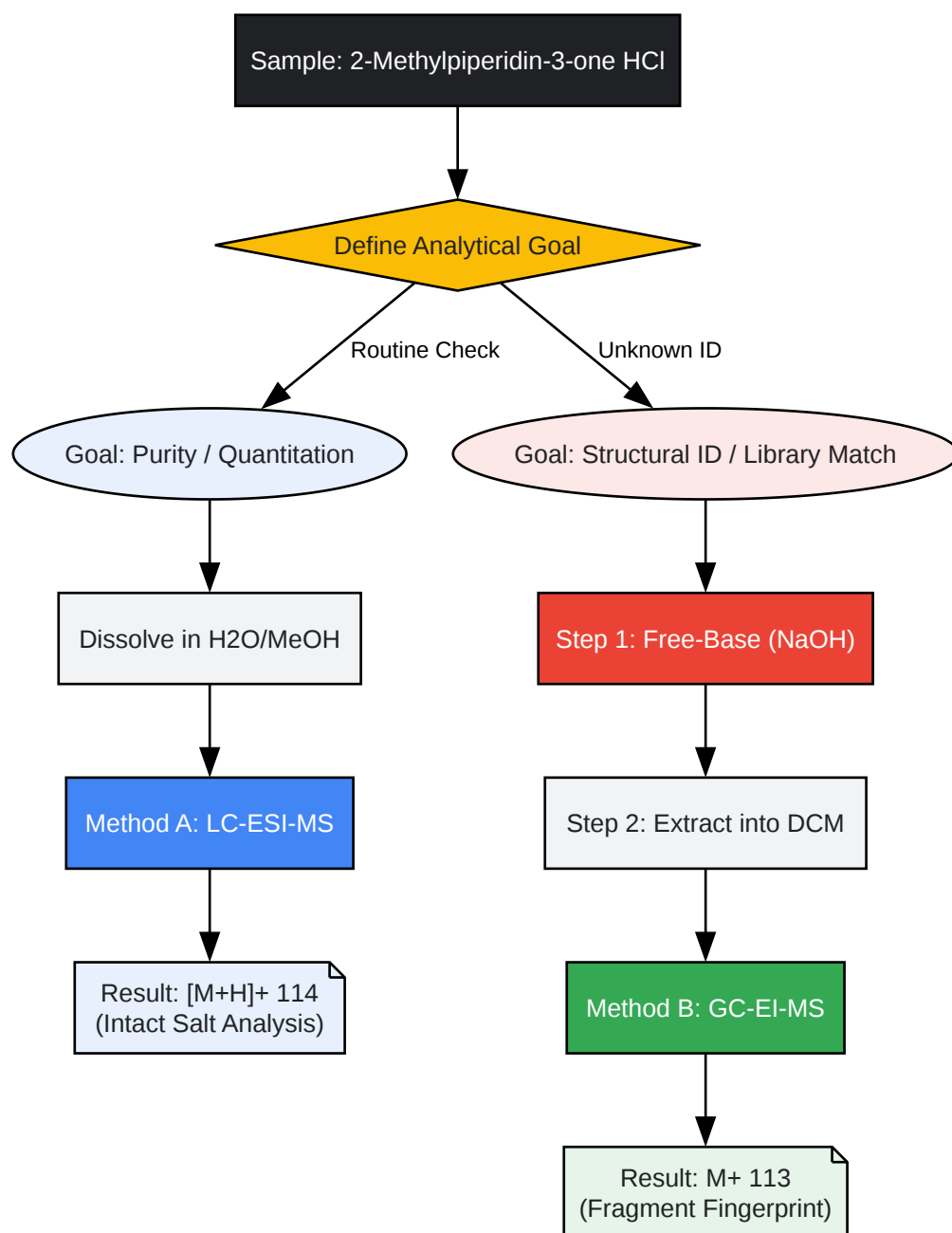

[Click to download full resolution via product page](#)

Figure 1: Decision tree for selecting LC-MS vs. GC-MS based on the need for salt-preservation vs. structural fingerprinting.[1][4]

Mechanistic Insight: Fragmentation Pathways[1][2] [3]

Understanding the fragmentation allows researchers to validate that the peak observed is indeed the target compound and not an isomer (e.g., 4-one vs 3-one).

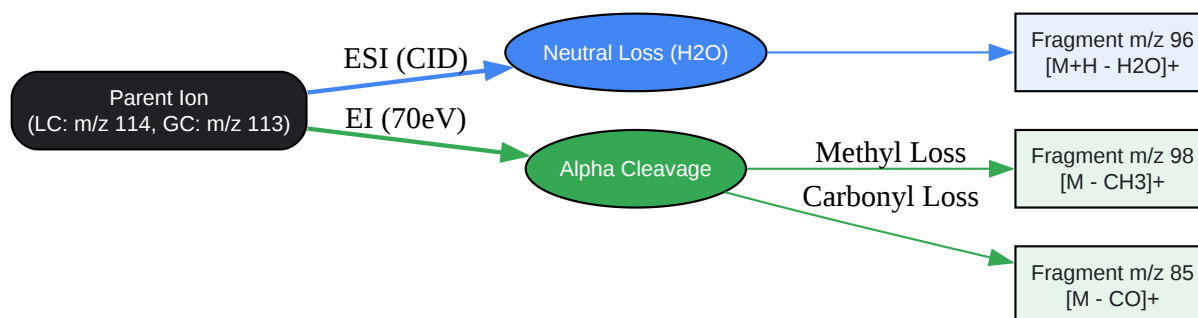

[Click to download full resolution via product page](#)

Figure 2: Distinct fragmentation pathways observed in ESI (Soft Ionization) vs. EI (Hard Ionization).

Conclusion & Recommendation

For routine analysis of 2-Methylpiperidin-3-one HCl in a drug development context, Method A (LC-ESI-MS) is recommended.[1] It eliminates the variability introduced by the liquid-liquid extraction required for GC and provides rapid confirmation of the molecular weight (

114).

Method B (GC-EI-MS) should be reserved for scenarios where:

- Isomeric differentiation is required (e.g., distinguishing from 2-methylpiperidin-4-one).[1]
- The sample is part of a complex mixture where chromatographic resolution on C18 is insufficient.

References

- NIST Mass Spectrometry Data Center. (2023).[1] 2-Methylpiperidine and Piperidinone Derivatives: Electron Ionization Spectra. National Institute of Standards and Technology.[5] [\[Link\]](#)[1]
- Biotage. (2023).[1][6] How does your sample prep change for LC/MS vs GC/MS. [\[Link\]](#)
- PubChem. (2023).[1] Piperidin-3-one hydrochloride Compound Summary. National Library of Medicine. [\[Link\]](#)
- Conquer Scientific. (2023). The Difference Between GC/MS and LC/MS Systems. [\[Link\]](#)

Need Custom Synthesis?

BenchChem offers custom synthesis for rare earth carbides and specific isotopic labeling.

Email: info@benchchem.com or [Request Quote Online](#).

Sources

- [1. chemscene.com](https://chemscene.com) [chemscene.com]
- [2. Mass Fragmentation Characteristics of Piperazine Analogues](https://zpxb.xml-journal.net) [zpxb.xml-journal.net]
- [3. pdf.benchchem.com](https://pdf.benchchem.com) [pdf.benchchem.com]
- [4. mdpi.com](https://mdpi.com) [mdpi.com]
- [5. 2-Methylpiperidine](https://webbook.nist.gov) [webbook.nist.gov]
- [6. conquerscientific.com](https://conquerscientific.com) [conquerscientific.com]
- To cite this document: BenchChem. [Comparative Guide: Mass Spectrometry Characterization of 2-Methylpiperidin-3-one HCl]. BenchChem, [2026]. [Online PDF]. Available at: [<https://www.benchchem.com/product/b2468489/docs#comparative-guide-mass-spectrometry-characterization-of-2-methylpiperidin-3-one-hcl>]

Disclaimer & Data Validity:

The information provided in this document is for Research Use Only (RUO) and is strictly not intended for diagnostic or therapeutic procedures. While BenchChem strives to provide

accurate protocols, we make no warranties, express or implied, regarding the fitness of this product for every specific experimental setup.

Technical Support: The protocols provided are for reference purposes. Unsure if this reagent suits your experiment?

Need Industrial/Bulk Grade? [Request Custom Synthesis Quote](#)

BenchChem

Our mission is to be the trusted global source of essential and advanced chemicals, empowering scientists and researchers to drive progress in science and industry.

Contact

Address: 3281 E Guasti Rd

Ontario, CA 91761, United States

Phone: (601) 213-4426

Email: info@benchchem.com

[Contact our Ph.D. Support Team for a compatibility check](#)