

# Comparative Analysis of Ionization Modalities and Fragmentation Dynamics: 4-Formylphenyl Cyclopropanecarboxylate

**Author:** BenchChem Technical Support Team. **Date:** May 2026

## Compound of Interest

Compound Name:	4-Formylphenyl cyclopropanecarboxylate
CAS No.:	588695-35-6
Cat. No.:	B2466016

[Get Quote](#)

## Executive Summary

### 4-Formylphenyl cyclopropanecarboxylate (

, MW 190.19 Da) represents a unique structural challenge in mass spectrometry due to the competing fragmentation pathways of its strained cyclopropane ring, the labile ester linkage, and the reactive formyl group.

This guide compares the two dominant analytical modalities—Electron Ionization (EI) and Electrospray Ionization (ESI)—to provide researchers with a roadmap for structural elucidation and impurity profiling. Unlike standard aliphatic esters, the cyclopropyl moiety introduces ring-strain-driven fragmentation kinetics that must be distinguished from standard alkyl chain losses.

## Core Comparison Matrix

Feature	Electron Ionization (EI)	Electrospray Ionization (ESI)
Primary Utility	Structural Fingerprinting & Library Matching	Quantification & Biological Matrix Analysis
Ionization Energy	Hard (70 eV)	Soft (Thermal/Voltage)
Dominant Species	Fragment Ions (69, 121, 162)	Adduct Ions ( , )
Detection Limit	Low picogram (scan dependent)	Femtogram (MRM mode)

## Structural Analysis & Theoretical Fragmentation

To accurately interpret the mass spectrum, one must understand the bond dissociation energies (BDE) governing the molecule's decay.

### The Cyclopropyl "Strain" Factor

Unlike an isopropyl ester (which fragments via standard McLafferty rearrangements), the cyclopropane ring possesses

27.5 kcal/mol of ring strain. This facilitates

-cleavage adjacent to the carbonyl carbon, often retaining the charge on the cyclopropyl acylium ion (

69) due to the stability of the cyclopropyl cation resonance forms.

### The Aromatic "Sink"

The 4-formylphenyl moiety acts as a charge sink. In EI, the formation of the 4-formylphenol radical cation (

122) via hydrogen abstraction is a competitive pathway against the formation of the acylium ion.

## Mechanistic Pathway Diagram

The following diagram illustrates the competing fragmentation pathways derived from first principles of organic mass spectrometry (Stevenson's Rule and charge localization).

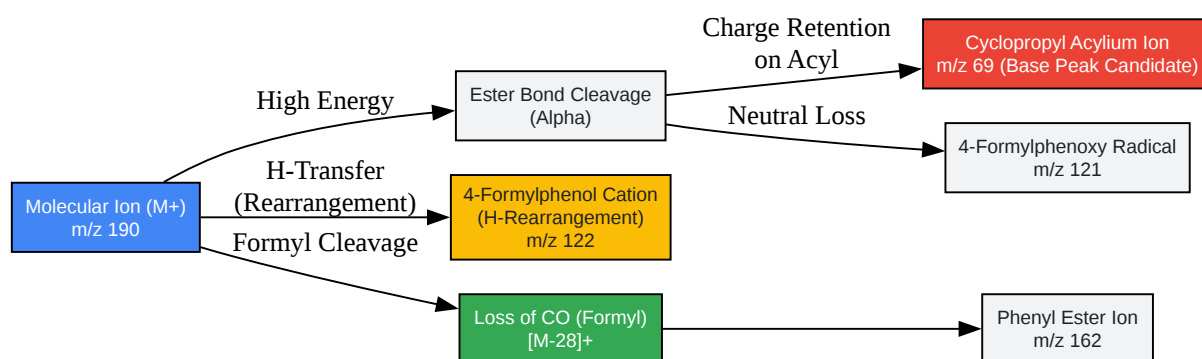

[Click to download full resolution via product page](#)

Figure 1: Predicted fragmentation tree highlighting the competition between acylium ion formation and aromatic stabilization.

## Detailed Comparative Guide: EI vs. ESI

### Scenario A: Electron Ionization (EI) - 70 eV

Best for: Identification of synthesis impurities and confirming the cyclopropyl vs. isopropyl structure.

In a standard 70 eV EI source, the molecular ion (

) at

190 is often visible but low intensity due to the labile ester bond.

- Diagnostic Peak 1 (

69): The cyclopropanecarbonyl cation. This is the "fingerprint" of the acid moiety. If this were an isopropyl ester, you would see

43 (

) or

71 (

). The shift to 69 is diagnostic for the cyclopropyl ring ( $C_3H_5 + CO$ ).

- Diagnostic Peak 2 (

121/122): The 4-formylphenoxy moiety.

121 represents the direct cleavage (

), while

122 represents the phenol cation formed via hydrogen abstraction from the cyclopropyl ring or background water.

- Diagnostic Peak 3 (

162): Loss of CO (28 Da) from the aldehyde group on the aromatic ring. This confirms the integrity of the formyl group in the parent structure.

## Scenario B: Electrospray Ionization (ESI) - Positive Mode

Best for: Pharmacokinetic (PK) studies and high-sensitivity quantification.

ESI is a "soft" technique. You will rarely see the fragments listed above in the primary scan (MS1).

- Primary Ion:

at

191.1.

- Adducts: Sodium adducts

at

213.1 are highly likely if glass or biological buffers are used.

- MS/MS (CID) Behavior: When subjected to Collision-Induced Dissociation (CID), the ion typically ejects the neutral carboxylic acid ( , 86 Da) to leave the protonated phenol, or ejects the phenol to leave the acylium ion.
  - Transition:  
(Protonated 4-formylphenol).
  - Transition:  
(Cyclopropyl acylium).

## Data Summary Table

m/z (Da)	Identity	Mode	Origin/Mechanism
190		EI	Molecular Ion (Weak)
191		ESI	Protonated Molecule (Base Peak)
213		ESI	Sodium Adduct
162		EI	Loss of CO from aldehyde
122		EI	4-Formylphenol radical cation (H-transfer)
69		EI/ESI	Cyclopropyl acylium (Diagnostic)

## Experimental Protocols

## Sample Preparation (Critical Step)

- Solvent Choice: Dissolve in Acetonitrile (ACN) or Dichloromethane (DCM).
  - Warning: Avoid Methanol for long-term storage. The formyl group is reactive, and the ester can undergo transesterification in protic solvents under acidic/basic conditions.
- Concentration:
  - For EI (GC-MS): 100 µg/mL (ppm).
  - For ESI (LC-MS): 1 µg/mL (ppb) with 0.1% Formic Acid to promote protonation.

## Method Development Workflow

The following workflow ensures self-validating data generation, checking for thermal degradation (common with esters in GC) before finalizing the method.

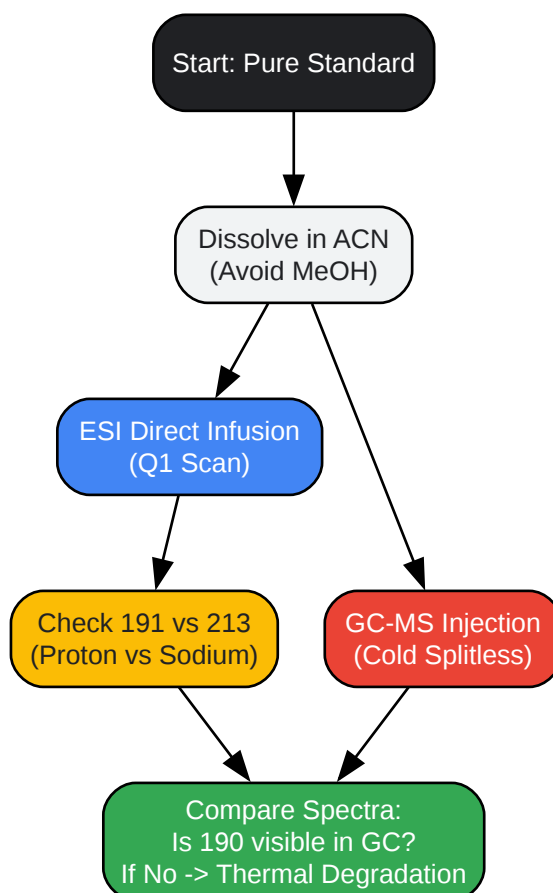

[Click to download full resolution via product page](#)

Figure 2: Step-by-step method development workflow to validate compound integrity across ionization modes.

## References & Authoritative Grounding

- NIST Mass Spectrometry Data Center. Fragmentation of Cyclopropanecarboxylic acid esters. NIST Chemistry WebBook, SRD 69.[1][2] Available at: [\[Link\]](#) (Accessed for analog comparison: Cyclopropanecarboxylic acid, 4-methoxyphenyl ester).
- McLafferty, F. W., & Tureček, F. (1993). Interpretation of Mass Spectra (4th ed.). University Science Books. (Source for general rules on ester -cleavage and ring strain effects).
- Silverstein, R. M., Webster, F. X., & Kiemle, D. J. (2005). Spectrometric Identification of Organic Compounds (7th ed.). John Wiley & Sons.[3] (Source for aromatic aldehyde fragmentation mechanisms).
- Gross, J. H. (2017). Mass Spectrometry: A Textbook (3rd ed.). Springer. (Source for ESI adduct formation and CID mechanisms).

### Need Custom Synthesis?

BenchChem offers custom synthesis for rare earth carbides and specific isotopic labeling.

Email: [info@benchchem.com](mailto:info@benchchem.com) or [Request Quote Online](#).

## Sources

- 1. Cyclopropanecarboxaldehyde [[webbook.nist.gov](http://webbook.nist.gov)]
- 2. Cyclopropanecarboxylic acid, 4-methoxyphenyl ester [[webbook.nist.gov](http://webbook.nist.gov)]
- 3. Fragmentation patterns of new esterified and unesterified aromatic 1-hydroxymethylene-1, 1-bisphosphonic acids by ESI-MSn - PubMed [[pubmed.ncbi.nlm.nih.gov](http://pubmed.ncbi.nlm.nih.gov)]
- To cite this document: BenchChem. [Comparative Analysis of Ionization Modalities and Fragmentation Dynamics: 4-Formylphenyl Cyclopropanecarboxylate]. BenchChem, [2026].

[Online PDF]. Available at:

[\[https://www.benchchem.com/product/b2466016/docs#comparative-analysis-of-ionization-modalities-and-fragmentation-dynamics-4-formylphenyl-cyclopropanecarboxylate\]](https://www.benchchem.com/product/b2466016/docs#comparative-analysis-of-ionization-modalities-and-fragmentation-dynamics-4-formylphenyl-cyclopropanecarboxylate)

---

**Disclaimer & Data Validity:**

The information provided in this document is for Research Use Only (RUO) and is strictly not intended for diagnostic or therapeutic procedures. While BenchChem strives to provide accurate protocols, we make no warranties, express or implied, regarding the fitness of this product for every specific experimental setup.

**Technical Support:** The protocols provided are for reference purposes. Unsure if this reagent suits your experiment?

**Need Industrial/Bulk Grade?** [Request Custom Synthesis Quote](#)

## BenchChem

Our mission is to be the trusted global source of essential and advanced chemicals, empowering scientists and researchers to drive progress in science and industry.

### Contact

Address: 3281 E Guasti Rd  
Ontario, CA 91761, United States  
Phone: (601) 213-4426  
Email: [info@benchchem.com](mailto:info@benchchem.com)

[Contact our Ph.D. Support Team for a compatibility check](#)