

# Technical Support Center: Troubleshooting Amide-to-Thioamide Transformations

**Author:** BenchChem Technical Support Team. **Date:** March 2026

## Compound of Interest

Compound Name: *N*-(3-nitrophenyl)ethanethioamide

CAS No.: 21115-69-5

Cat. No.: B2465371

[Get Quote](#)

The conversion of amides to their corresponding thioamides is a cornerstone of synthetic and medicinal chemistry. This transformation introduces a unique bioisostere that can significantly alter a molecule's biological activity, metabolic stability, and physicochemical properties.[1] While seemingly straightforward, this thionation reaction can present numerous challenges, leading to low conversion rates, undesired side products, and purification difficulties.

This guide provides a comprehensive troubleshooting resource for researchers, scientists, and drug development professionals encountering issues with this critical transformation. The following question-and-answer format directly addresses common problems, offering insights into their root causes and providing actionable, field-proven solutions.

## Fundamental Principles of Amide Thionation

The most prevalent method for converting amides to thioamides involves the use of a sulfur-transfer reagent.[1] The choice of this thionating agent is a critical parameter that can profoundly influence the reaction's efficiency, compatibility with various substrates, and overall yield.[2] Among the most established and effective thionating agents are Lawesson's Reagent and Phosphorus Pentasulfide (P<sub>4</sub>S<sub>10</sub>).[1]

The general mechanism for thionation with reagents like Lawesson's Reagent involves the formation of a highly reactive dithiophosphine ylide intermediate. This intermediate undergoes a cycloaddition reaction with the amide's carbonyl group, forming a transient four-membered thioxaphosphetane intermediate. This intermediate subsequently undergoes cycloreversion,

driven by the formation of a stable phosphorus-oxygen double bond, to yield the desired thioamide and a phosphorus-containing byproduct.[3]

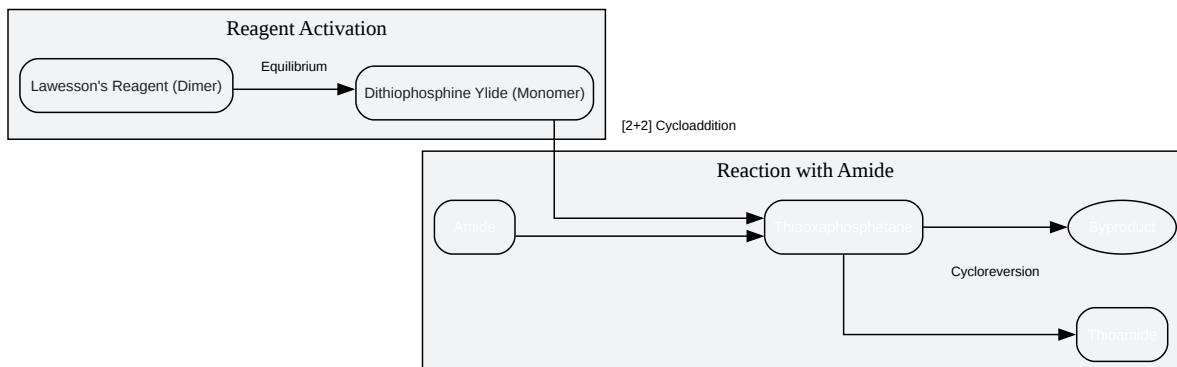

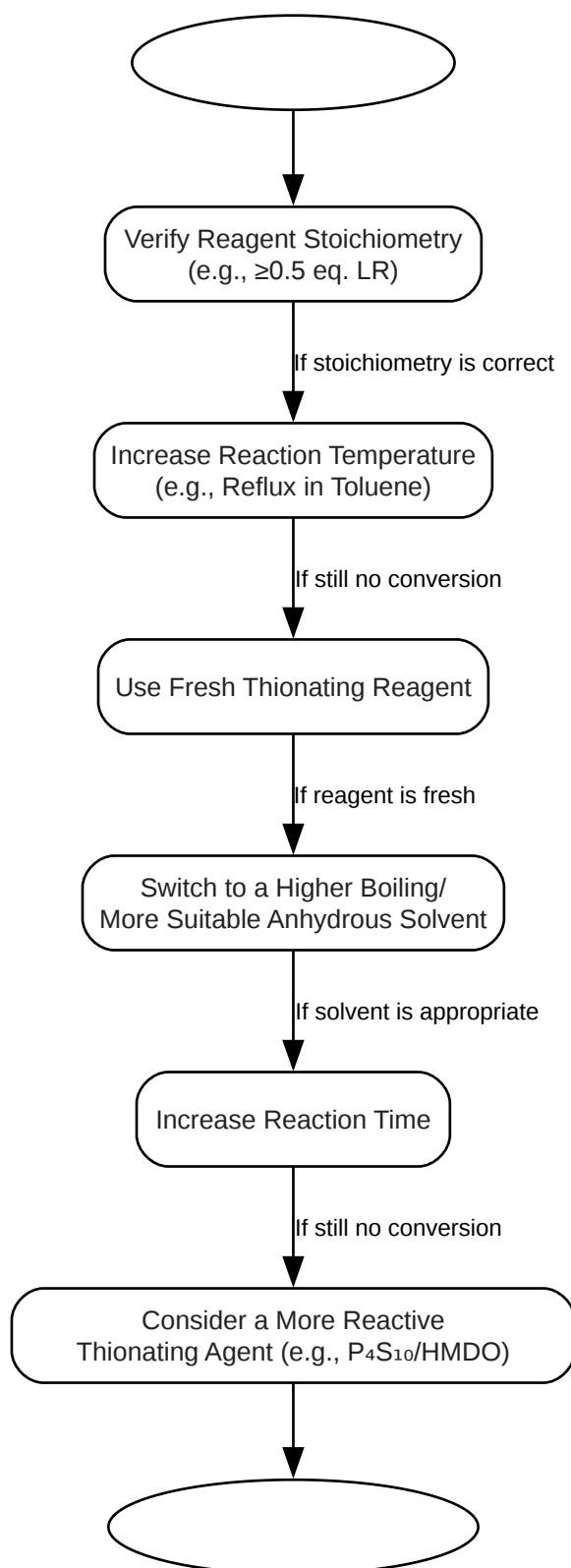

[Click to download full resolution via product page](#)

Caption: Decision-making workflow for troubleshooting low conversion rates.

## Q2: I am observing the formation of significant side products. What are they and how can I minimize them?

A2: Side product formation can complicate purification and reduce the yield of the desired thioamide. Common side reactions and their mitigation strategies include:

- **Decomposition of Starting Material or Product:** Some amides or thioamides may not be stable under the prolonged heating required for thionation. If you suspect this is the case, try to run the reaction at a lower temperature for a longer period or consider using a more reactive thionating agent that allows for milder reaction conditions. Microwave-assisted synthesis can sometimes be beneficial in reducing reaction times and minimizing thermal degradation.
- **Reaction with Other Functional Groups:** While thionating reagents are generally chemoselective for carbonyl groups, reactions with other functional groups can occur, especially under harsh conditions. For instance, Lawesson's reagent can convert alcohols to thiols and sulfoxides to thioethers. [4] If your substrate contains sensitive functional groups, using milder conditions or a more selective reagent is advisable.
- **Formation of Complex Phosphorus-Sulfur Byproducts:** Particularly with  $P_4S_{10}$ , highly condensed polythiophosphates can form, which can act as electrophiles and promote unwanted side reactions. [5] Using  $P_4S_{10}$  in combination with a reagent like hexamethyldisiloxane (HMDO), also known as Curphey's Reagent, can lead to cleaner reactions and simpler workups. [6][7][8] **Experimental Protocol: General Thionation using Lawesson's Reagent** [1][3]
- **Preparation:** In a flame-dried round-bottom flask equipped with a magnetic stir bar and a reflux condenser, add the amide (1.0 eq).
- **Reagent Addition:** Add Lawesson's Reagent (0.5 - 1.0 eq) to the flask.
- **Solvent Addition:** Add anhydrous toluene (or another suitable high-boiling solvent) to the flask under an inert atmosphere (e.g., nitrogen or argon). [3] **4. Heating:** Heat the reaction mixture to reflux and monitor the progress by Thin Layer Chromatography (TLC) or Liquid Chromatography-Mass Spectrometry (LC-MS). [3] **5. Workup:** Once the reaction is complete,

cool the mixture to room temperature and remove the solvent under reduced pressure. The crude residue can then be purified by column chromatography. [3]

### Q3: The purification of my thioamide is very difficult due to byproducts from the thionating reagent. What are my options?

A3: Purification is a common hurdle, as the phosphorus-containing byproducts from reagents like Lawesson's can be challenging to separate from the desired thioamide. [9] Here are several strategies to address this:

- **Alternative Reagents with Easier Workup:** The combination of  $P_4S_{10}$  and hexamethyldisiloxane (HMDO) often provides reagent-derived byproducts that can be removed by a simple hydrolytic workup or filtration through silica gel, which can be a significant advantage over Lawesson's reagent. [6][7][8]\* **Modified Lawesson's Reagents:** Fluorine-containing Lawesson's reagents have been developed to aid in product separation through fluorous solid-phase extraction. [10]\* **Aqueous Workup:** A thorough aqueous workup can sometimes help to remove some of the more polar byproducts. Washing the organic layer with a saturated sodium bicarbonate solution or water may be effective.
- **Chromatography on Different Stationary Phases:** If standard silica gel chromatography is not providing adequate separation, consider using a different stationary phase, such as alumina. [9]\* **Crystallization:** If your thioamide is a solid, recrystallization can be a highly effective method for purification.

Comparison of Common Thionating Reagents:

Reagent	Key Features	Common Issues
Lawesson's Reagent (LR)	Mild, soluble in many organic solvents, high yields for a variety of substrates. [2]	Difficult to remove byproducts by chromatography. [9]
Phosphorus Pentasulfide (P <sub>4</sub> S <sub>10</sub> )	Inexpensive, powerful thionating agent. [2]	Often requires harsh reaction conditions, can lead to side reactions. [2][5]
Curphey's Reagent (P <sub>4</sub> S <sub>10</sub> /HMDO)	Enhanced reactivity compared to P <sub>4</sub> S <sub>10</sub> alone, often provides cleaner reactions and simpler workup than LR. [2][6][7]	HMDO is moisture sensitive.
P <sub>4</sub> S <sub>10</sub> -Pyridine Complex	High thermal stability, suitable for high-temperature reactions where LR might decompose. [2]	Preparation of the complex is an additional step.

## Q4: How can I effectively monitor the progress of my amide-to-thioamide transformation?

A4: Careful reaction monitoring is essential to determine the optimal reaction time and to avoid over- or under-reaction.

- Thin Layer Chromatography (TLC): TLC is the most common and convenient method for monitoring these reactions. [2] Thioamides are generally less polar than their corresponding amides, so the product spot should have a higher R<sub>f</sub> value. It is advisable to run a co-spot of the starting material and the reaction mixture to accurately track the disappearance of the starting material and the appearance of the product.
- Liquid Chromatography-Mass Spectrometry (LC-MS): For more complex reaction mixtures or for substrates that are difficult to visualize on TLC, LC-MS is a powerful tool. It provides information on the conversion of the starting material and can help to identify the masses of the product and any side products, aiding in troubleshooting.

By systematically addressing these common issues, researchers can significantly improve the success rate of their amide-to-thioamide transformations, a critical step in the synthesis of novel compounds for drug discovery and development.

## References

- BenchChem. (2025). Application Notes: Protocol for the Conversion of Amides to Thioamides. BenchChem.
- BenchChem. (2025). A Head-to-Head Comparison of Thionating Reagents for Organic Synthesis. BenchChem.
- Li, A. Y. (n.d.). Thionation with the Reagent Combination of Phosphorus Pentasulfide and Hexamethyldisiloxane.
- Alfa Chemistry. (n.d.). Lawesson's Reagent. Alfa Chemistry.
- Wikipedia. (n.d.). Lawesson's reagent. Wikipedia.
- BenchChem. (2025). Introduction to thionation reactions in organic synthesis. BenchChem.
- Organic Chemistry Portal. (n.d.). Lawesson's Reagent. Organic Chemistry Portal.
- Recent advances in thionating reagents for the synthesis of organosulfur compounds. (n.d.).
- Thionation with the reagent combination of phosphorus pentasulfide and hexamethyldisiloxane. (2002, September 6). PubMed.
- Synthesis of Thionated Perylenediimides: State of the Art and First Investigations of an Alternative to Lawesson's Reagent. (2024, May 28). PMC.
- Thioimide Solutions to Thioamide Problems during Peptide Synthesis. (n.d.). Request PDF.
- Thionation with the Reagent Combination of Phosphorus Pentasulfide and Hexamethyldisiloxane | The Journal of Organic Chemistry. (2002, August 15).
- A Focused Review of Synthetic Applications of Lawesson's Reagent in Organic Synthesis. (2021, November 17).
- Le, L. (2013, August 16). Preparation of Phosphorus Pentasulfide - A Thionation Reagent.
- Mechanism of the Reaction of Lawesson's Reagent with N-Alkylhydroxamic Acids. (2025, August 6).
- Recent Advances in Thionating Reagents for the Synthesis of Organosulfur Compounds. (2025, August 6).
- Efficient Synthesis of Amides through Thioacids Reactions with In Situ Generated Formamidine | The Journal of Organic Chemistry. (2025, October 28).
- Opportunities and challenges in the synthesis of thioamid
- Thioamide synthesis by thion
- Thioimide Solutions to Thioamide Problems during Peptide Synthesis. (n.d.). ChemRxiv.
- Transformation of Amides to Thioamides Using an Efficient and Novel Thi

- A novel method for heterocyclic amide–thioamide transformations. (2017, January 26). Beilstein Journals.
- Issues during thiol synthesis : r/chemistry. (2023, July 11). Reddit.
- BenchChem. (2025). Application Notes and Protocols for the Synthesis of Thioamides Using Lawesson's Reagent. BenchChem.

### Need Custom Synthesis?

BenchChem offers custom synthesis for rare earth carbides and specific isotopic labeling.

Email: [info@benchchem.com](mailto:info@benchchem.com) or [Request Quote Online](#).

## Sources

- [1. pdf.benchchem.com \[pdf.benchchem.com\]](#)
- [2. pdf.benchchem.com \[pdf.benchchem.com\]](#)
- [3. pdf.benchchem.com \[pdf.benchchem.com\]](#)
- [4. Lawesson's reagent - Wikipedia \[en.wikipedia.org\]](#)
- [5. researchgate.net \[researchgate.net\]](#)
- [6. audreyli.com \[audreyli.com\]](#)
- [7. Thionation with the reagent combination of phosphorus pentasulfide and hexamethyldisiloxane - PubMed \[pubmed.ncbi.nlm.nih.gov\]](#)
- [8. pubs.acs.org \[pubs.acs.org\]](#)
- [9. reddit.com \[reddit.com\]](#)
- [10. alfa-chemistry.com \[alfa-chemistry.com\]](#)
- To cite this document: BenchChem. [Technical Support Center: Troubleshooting Amide-to-Thioamide Transformations]. BenchChem, [2026]. [Online PDF]. Available at: [\[https://www.benchchem.com/product/b2465371#troubleshooting-low-conversion-rates-in-amide-to-thioamide-transformation\]](https://www.benchchem.com/product/b2465371#troubleshooting-low-conversion-rates-in-amide-to-thioamide-transformation)

---

### Disclaimer & Data Validity:

The information provided in this document is for Research Use Only (RUO) and is strictly not intended for diagnostic or therapeutic procedures. While BenchChem strives to provide

accurate protocols, we make no warranties, express or implied, regarding the fitness of this product for every specific experimental setup.

**Technical Support:** The protocols provided are for reference purposes. Unsure if this reagent suits your experiment? [[Contact our Ph.D. Support Team for a compatibility check](#)]

**Need Industrial/Bulk Grade?** [Request Custom Synthesis Quote](#)

## BenchChem

Our mission is to be the trusted global source of essential and advanced chemicals, empowering scientists and researchers to drive progress in science and industry.

### Contact

Address: 3281 E Guasti Rd

Ontario, CA 91761, United States

Phone: (601) 213-4426

Email: [info@benchchem.com](mailto:info@benchchem.com)