

Technical Support Center: Accelerating Reactions for Sterically Hindered Cyclohexyl Pyrazoles

Author: BenchChem Technical Support Team. **Date:** April 2026

Compound of Interest

Compound Name:	5-Amino-1-cyclohexyl-1H-pyrazole-4-carbonitrile
CAS No.:	21254-04-6
Cat. No.:	B2463420

[Get Quote](#)

Welcome to the technical support hub for researchers, chemists, and drug development professionals. This guide is designed to address the unique challenges associated with the synthesis and functionalization of sterically hindered cyclohexyl pyrazoles. The bulky, non-planar nature of the cyclohexyl group often leads to sluggish reaction rates, low yields, and selectivity issues. This document provides in-depth, field-proven insights and troubleshooting strategies in a direct question-and-answer format to help you navigate these complexities and enhance your experimental outcomes.

Section 1: Foundational Challenges in Pyrazole Ring Formation

This section addresses the primary hurdles encountered during the initial construction of the sterically encumbered pyrazole core.

Q1: My standard Knorr pyrazole synthesis with a cyclohexyl-bearing 1,3-dicarbonyl compound is extremely slow and gives poor yields. What is the underlying cause?

A1: The primary cause is significant steric hindrance imposed by the bulky cyclohexyl group. In the classic Knorr pyrazole synthesis, the reaction proceeds via the condensation of a 1,3-dicarbonyl compound with a hydrazine derivative.^{[1][2]} The cyclohexyl moiety physically obstructs the approach of the hydrazine nucleophile to the carbonyl carbons. This raises the activation energy of the key condensation and subsequent cyclization-dehydration steps, leading to slow reaction rates and low conversion at standard temperatures.

Furthermore, impurities in starting materials can lead to unwanted side reactions, further reducing yields and complicating purification.^[3] It is crucial to use high-purity reagents to ensure a clean and predictable reaction outcome.^[3]

Q2: Given the steric hindrance, how can I optimize my reaction conditions for the initial cyclocondensation without resorting to specialized equipment?

A2: Optimizing conventional reaction conditions can yield significant improvements. The key is to provide enough energy to overcome the sterically-induced energy barrier while managing side reactions.

- **Solvent Selection:** The choice of solvent is critical. While polar protic solvents like ethanol are common, aprotic dipolar solvents such as DMF, DMSO, or NMP have been shown to be more effective for challenging cyclocondensations, often leading to better yields.^[3]
- **Temperature:** Increasing the reaction temperature is the most direct way to increase the reaction rate. Refluxing in a higher-boiling solvent like toluene or DMF can be effective. However, monitor the reaction closely for decomposition.
- **Catalysis:** The reaction is typically acid-catalyzed.^{[2][4]} While sometimes conducted in acetic acid as both solvent and catalyst, using a catalytic amount of a stronger acid like H₂SO₄ or a

solid acid catalyst like nano-ZnO in a neutral solvent can enhance the rate of both the initial condensation and the final dehydration step.[3]

Table 1: Effect of Solvent on a Hypothetical Hindered Knorr Synthesis

Solvent	Boiling Point (°C)	Typical Reaction Time (h)	Hypothetical Yield (%)	Rationale
Ethanol	78	24 - 48	30 - 45%	Common, but often too low-boiling for hindered substrates.
Acetic Acid	118	12 - 24	50 - 65%	Acts as both solvent and catalyst, promoting dehydration.
Toluene	111	12 - 18	60 - 75%	Allows for higher temperatures; can use a Dean-Stark trap to remove water.

| DMF | 153 | 8 - 12 | 70 - 85% | High boiling point and aprotic nature can accelerate the reaction.[3] |

Section 2: Advanced & Alternative Methodologies to Enhance Reaction Rates

When conventional heating is insufficient, alternative energy sources can provide the necessary activation to drive difficult reactions to completion.

Q3: I've heard that microwave synthesis can accelerate difficult reactions. Is it suitable for my sterically hindered system, and what are the risks?

A3: Yes, microwave (MW)-assisted synthesis is an exceptionally powerful technique for overcoming the challenges of steric hindrance.^{[5][6][7]} Unlike conventional heating which relies on thermal conduction, microwave irradiation uses dielectric heating to rapidly and uniformly heat the reaction mixture.^[7] This allows for reaching high temperatures and pressures in a sealed vessel, dramatically reducing reaction times from hours to minutes.^{[5][8]} This technique has been successfully used to synthesize a wide range of pyrazole derivatives with high efficiency.^{[1][8][9]}

Causality: The rapid heating can access kinetic regimes not easily achievable with an oil bath, often leading to cleaner reactions and higher yields by minimizing the time reactants are exposed to high temperatures, thereby reducing byproduct formation.^[6]

Protocol: Microwave-Assisted Synthesis of a Cyclohexyl Pyrazole

- **Reagent Preparation:** In a 10 mL microwave-safe vessel, combine the cyclohexyl-1,3-dicarbonyl compound (1.0 eq), the hydrazine derivative (1.1 eq), and a suitable high-boiling solvent (e.g., DMSO, 3-5 mL).^[1] Add a catalytic amount of acetic acid (0.1 eq).
- **Vessel Sealing:** Securely cap the vessel.
- **Microwave Irradiation:** Place the vessel in the microwave reactor. Irradiate at a set temperature (e.g., 140-160 °C) for a short duration (e.g., 10-30 minutes).^[1] Monitor the internal pressure to ensure it remains within safe limits.
- **Cooling & Work-up:** Allow the vessel to cool to room temperature before opening. Proceed with a standard aqueous work-up and purification by chromatography or recrystallization.

Q4: What about other non-conventional methods like ultrasound or flow chemistry?

A4: Both ultrasound and flow chemistry offer distinct advantages for hindered systems.

- **Ultrasound-Assisted Synthesis:** This technique uses acoustic cavitation—the formation, growth, and collapse of microscopic bubbles—to create localized hot spots with extremely high temperatures and pressures.[10] This intense energy input can significantly accelerate reaction rates, often at or near room temperature.[11] It is an excellent, energy-efficient alternative, particularly for processes that require milder bulk conditions.[8][10][12]
- **Flow Chemistry:** This approach involves pumping reactants through a heated and pressurized tube or microreactor.[13][14][15] The small reactor volume allows for superior heat and mass transfer, precise temperature control, and the ability to safely operate at temperatures and pressures far exceeding those possible in a batch reactor.[13][16] For sluggish reactions, this "superheating" capability can lead to dramatic rate enhancements and is highly amenable to scale-up.[14][17]

Table 2: Comparison of Heating Methodologies for Hindered Pyrazole Synthesis

Method	Typical Time	Typical Temp.	Key Advantage	Primary Mechanism
Conventional	12 - 48 h	80 - 150 °C	Accessible	Thermal Conduction
Microwave	10 - 30 min[8]	140 - 180 °C	Speed & Efficiency[6]	Dielectric Heating
Ultrasound	1 - 4 h[11]	25 - 60 °C	Mild Conditions	Acoustic Cavitation[10]

| Flow Chemistry | < 15 min | 160 - 220 °C | Control & Scalability[16] | Superheating & Transfer |

Diagram: Conceptual Flow Chemistry Setup

This diagram illustrates a basic setup for accelerating a reaction using flow chemistry.

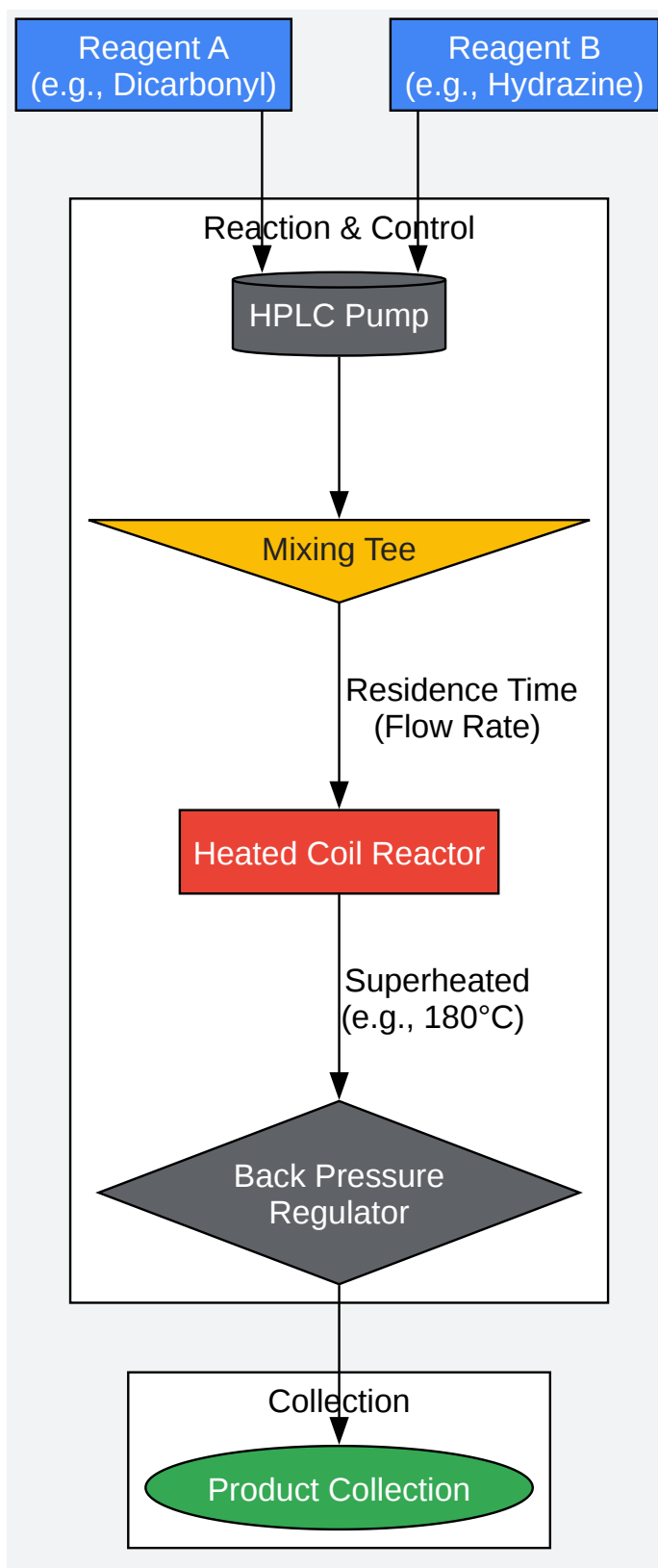

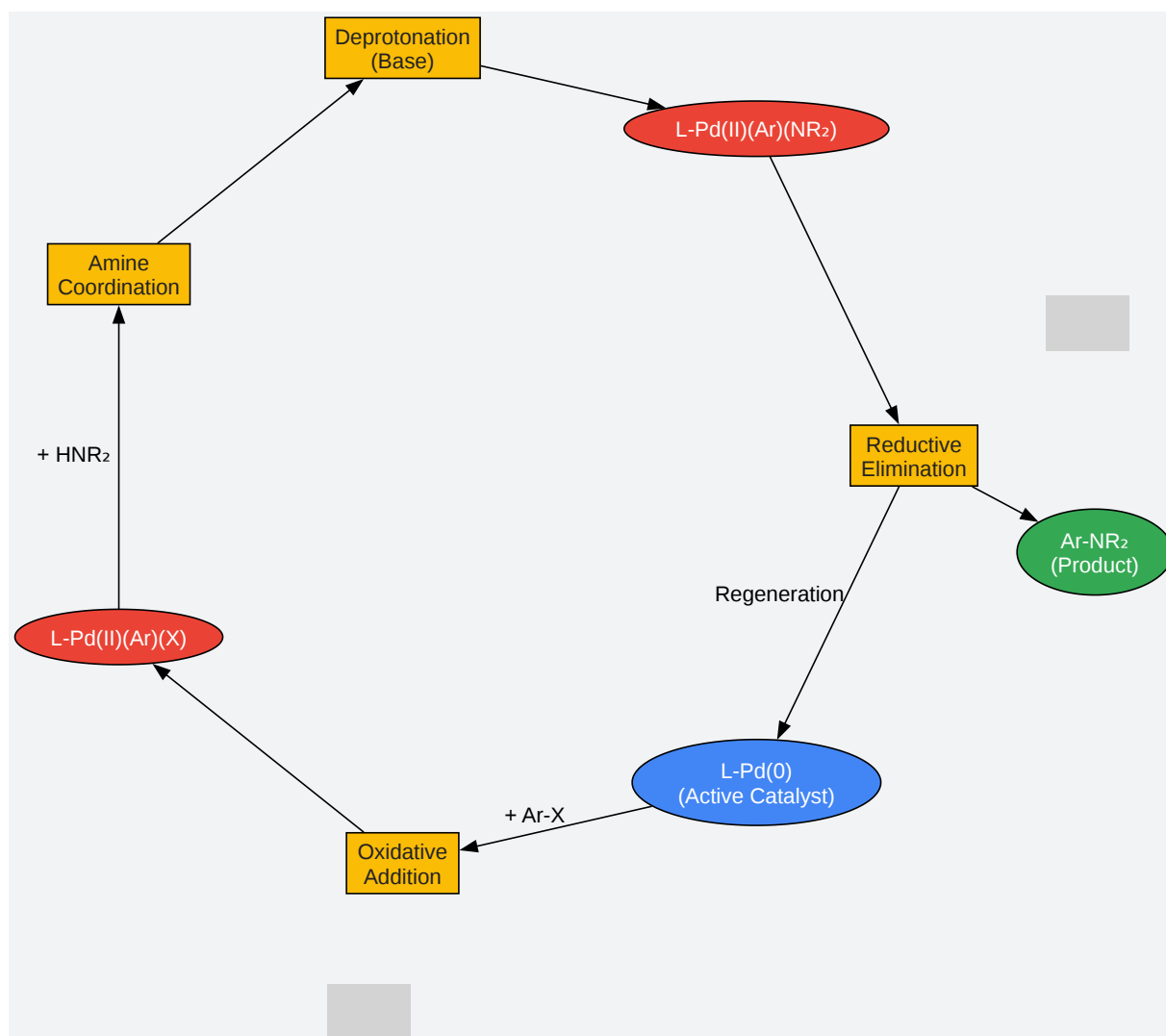

[Click to download full resolution via product page](#)

Caption: Steric hindrance primarily slows oxidative addition and reductive elimination steps.

Q6: My Suzuki-Miyaura couplings to form C-C bonds on the pyrazole ring are also low-yielding. Do the same principles apply?

A6: Yes, precisely. The Suzuki-Miyaura reaction faces the same mechanistic hurdles of oxidative addition and reductive elimination, which are exacerbated by steric bulk. [18] The solution is again found in ligand selection. Robust N-heterocyclic carbene (NHC) palladium complexes and specialized bulky phosphine ligands (e.g., SPhos, XPhos, or Amphos) are highly effective for coupling sterically hindered aryl halides with hindered boronic acids. [18][19] [20] Careful optimization of the base (e.g., K_3PO_4 , CS_2CO_3) and solvent (e.g., dioxane, toluene) is also critical for success. [18][19]

Experimental Protocols

Protocol: Optimized Buchwald-Hartwig Amination of 4-Bromo-1-cyclohexyl-pyrazole

This protocol is a starting point and may require optimization for your specific substrates.

- **Glovebox Setup:** Inside an inert atmosphere glovebox, add the 4-bromo-1-cyclohexyl-pyrazole (1.0 mmol, 1.0 eq), the desired amine (1.2 mmol, 1.2 eq), NaOt-Bu (1.4 mmol, 1.4 eq), your chosen bulky phosphine ligand (e.g., tBuXPhos, 0.02 mmol, 2 mol%), and the palladium precursor (e.g., $Pd_2(dba)_3$, 0.005 mmol, 0.5 mol%) to an oven-dried reaction vial equipped with a stir bar. [21] 2. **Solvent Addition:** Add anhydrous toluene or dioxane (3-5 mL).
- **Reaction Execution:** Seal the vial tightly with a Teflon-lined cap. Remove from the glovebox and place in a preheated oil bath at 100-110 °C.
- **Monitoring:** Stir vigorously for 12-24 hours. Monitor the reaction progress by TLC or LC-MS.
- **Work-up:** After cooling to room temperature, dilute the mixture with ethyl acetate and filter through a pad of celite to remove palladium black. Wash the filtrate with water and brine.
- **Purification:** Dry the organic layer over Na_2SO_4 , filter, and concentrate under reduced pressure. Purify the crude product by flash column chromatography on silica gel.

References

- ResearchGate. Flow Chemistry: Towards A More Sustainable Heterocyclic Synthesis. Available at: [\[Link\]](#)
- Springer. Flow Chemistry for the Synthesis of Heterocycles. Available at: [\[Link\]](#)
- MDPI. Continuous Flow Synthesis of Heterocycles: A Recent Update on the Flow Synthesis of Indoles. Available at: [\[Link\]](#)
- Springer. Flow Chemistry: Sequential Flow Processes for the Synthesis of Heterocycles. Available at: [\[Link\]](#)
- Springer. Flow Chemistry for the Synthesis of Heterocycles. Available at: [\[Link\]](#)
- Semantic Scholar. Recent advances in the synthesis of anticancer pyrazole derivatives using microwave, ultrasound, and mechanochemical techniques. Available at: [\[Link\]](#)
- Bentham Science. Recent Advances in the Microwave and Ultrasound-Assisted Synthesis of Pyrazole Scaffolds. Available at: [\[Link\]](#)
- RSC Publishing. Synthesis of tetra-substituted 5-trifluoromethylpyrazoles via sequential halogenation/palladium-catalyzed C–C and C–N cross-coupling. Available at: [\[Link\]](#)
- PMC. Mechanistic Study of Pyrazole Synthesis via Oxidation-Induced N-N Coupling of Diazatitanacycles. Available at: [\[Link\]](#)
- Der Pharma Chemica. Ultrasound mediated synthesis of some pyrazoline derivatives using biocompatible deep eutectic solvent (DES). Available at: [\[Link\]](#)
- RSC Publishing. Ultrasound-assisted transition-metal-free catalysis: a sustainable route towards the synthesis of bioactive heterocycles. Available at: [\[Link\]](#)
- BEPLS. Ultrasound Assisted One-Pot Green Synthesis of Highly Substituted Pyrazoles Catalyzed by [DBUH][OAc] Ionic Liquid. Available at: [\[Link\]](#)
- ResearchGate. Mechanism for the formation of pyrazole. Available at: [\[Link\]](#)

- Name-Reaction.com. Knorr pyrazole synthesis. Available at: [\[Link\]](#)
- ACS Publications. Metal–N-Heterocyclic Carbene Complexes in Buchwald–Hartwig Amination Reactions. Available at: [\[Link\]](#)
- Organic Chemistry Portal. Robust Acenaphthoimidazolylidene Palladium Complexes: Highly Efficient Catalysts for Suzuki-Miyaura Couplings with Sterically Hindered Substrates. Available at: [\[Link\]](#)
- SlideShare. Pyrazole. Available at: [\[Link\]](#)
- PubMed. Synthesis of tetra-substituted 5-trifluoromethylpyrazoles via sequential halogenation/palladium-catalyzed C-C and C-N cross-coupling. Available at: [\[Link\]](#)
- Organic Chemistry Portal. Rational Ligand Design for the Arylation of Hindered Primary Amines Guided by Reaction Progress Kinetic Analysis. Available at: [\[Link\]](#)
- Organic Chemistry Portal. Pyrazole synthesis. Available at: [\[Link\]](#)
- Wikipedia. Buchwald–Hartwig amination. Available at: [\[Link\]](#)
- PMC. Cu-Catalyzed C–N Coupling with Sterically Hindered Partners. Available at: [\[Link\]](#)
- PubMed. An efficient method for sterically demanding Suzuki-Miyaura coupling reactions. Available at: [\[Link\]](#)
- University of Oradea. View of Microwave-assisted synthesis of a series of 4,5-dihydro-1H-pyrazoles endowed with selective COX-1 inhibitory potency. Available at: [\[Link\]](#)
- PMC. Orchestrated Triple C–H Activation Reactions Using Two Directing Groups: Rapid Assembly of Complex Pyrazoles. Available at: [\[Link\]](#)
- DergiPark. Microwave-assisted synthesis of pyrazoles - a mini-review. Available at: [\[Link\]](#)
- Bentham Science Publishers. Recent Advances in the Microwave and Ultrasound-Assisted Synthesis of Pyrazole Scaffolds. Available at: [\[Link\]](#)

- ResearchGate. Regioselective Synthesis of 4,4'-Bipyrazoles via Palladium-Catalyzed Cyclizative Dimerization of Alkynic Hydrazones. Available at: [\[Link\]](#)
- Preprints.org. Recent Advances in N-Heterocyclic Chemistry: Innovative Strategies for Pyrazole Derivative Synthesis. Available at: [\[Link\]](#)
- HETEROCYCLES. MICROWAVE-ASSISTED SYNTHESIS OF PYRAZOLES BY 1,3-DIPOLAR CYCLOADDITION OF DIAZO COMPOUNDS TO ACETYLENE DERIVATIVES. Available at: [\[Link\]](#)
- Asian Journal of Chemistry. Synthesis and Spectroscopic Characterization of Palladium(II) and Platinum(II) Complexes with Substituted Pyrazoles. Available at: [\[Link\]](#)
- PubMed. Microwave-assisted Synthesis of Novel Pyrazole Derivatives and their Biological Evaluation as Anti-Bacterial Agents. Available at: [\[Link\]](#)
- Chemical Society Reviews. Suzuki–Miyaura (hetero-)aryl cross-coupling: recent findings and recommendations. Available at: [\[Link\]](#)
- NSF-MMLI. Closed-loop optimization of general reaction conditions for heteroaryl Suzuki–Miyaura coupling. Available at: [\[Link\]](#)
- MDPI. Synthesis of Novel Tetra-Substituted Pyrazole Derivatives Using Microwave Irradiation and Their Anti-Leukemic Activity Against Jurkat Cells. Available at: [\[Link\]](#)
- PMC. Recent highlights in the synthesis and biological significance of pyrazole derivatives. Available at: [\[Link\]](#)
- Organic Chemistry Portal. Palladium-Catalyzed Synthesis of Polysubstituted Pyrazoles by Ring-Opening Reactions of 2H-Azirines with Hydrazones. Available at: [\[Link\]](#)
- ResearchGate. Phase-Transfer-Catalyzed Asymmetric Synthesis of Chiral N-Substituted Pyrazoles by Aza-Michael Reaction. Available at: [\[Link\]](#)

Need Custom Synthesis?

BenchChem offers custom synthesis for rare earth carbides and specific isotopic labeling.

Email: info@benchchem.com or [Request Quote Online](#).

Sources

- [1. pdf.benchchem.com \[pdf.benchchem.com\]](https://pdf.benchchem.com)
- [2. name-reaction.com \[name-reaction.com\]](https://name-reaction.com)
- [3. pdf.benchchem.com \[pdf.benchchem.com\]](https://pdf.benchchem.com)
- [4. pdf.benchchem.com \[pdf.benchchem.com\]](https://pdf.benchchem.com)
- [5. benthamdirect.com \[benthamdirect.com\]](https://benthamdirect.com)
- [6. dergipark.org.tr \[dergipark.org.tr\]](https://dergipark.org.tr)
- [7. eurekaselect.com \[eurekaselect.com\]](https://eurekaselect.com)
- [8. pdfs.semanticscholar.org \[pdfs.semanticscholar.org\]](https://pdfs.semanticscholar.org)
- [9. Microwave-assisted Synthesis of Novel Pyrazole Derivatives and their Biological Evaluation as Anti-Bacterial Agents - PubMed \[pubmed.ncbi.nlm.nih.gov\]](https://pubmed.ncbi.nlm.nih.gov)
- [10. bepls.com \[bepls.com\]](https://bepls.com)
- [11. derpharmachemica.com \[derpharmachemica.com\]](https://derpharmachemica.com)
- [12. Ultrasound-assisted transition-metal-free catalysis: a sustainable route towards the synthesis of bioactive heterocycles - RSC Advances \(RSC Publishing\) DOI:10.1039/D2RA02063G \[pubs.rsc.org\]](https://pubs.rsc.org)
- [13. researchgate.net \[researchgate.net\]](https://researchgate.net)
- [14. Flow Chemistry for the Synthesis of Heterocycles | springerprofessional.de \[springerprofessional.de\]](https://springerprofessional.de)
- [15. science.egasmoniz.com.pt \[science.egasmoniz.com.pt\]](https://science.egasmoniz.com.pt)
- [16. mdpi.com \[mdpi.com\]](https://mdpi.com)
- [17. Flow Chemistry for the Synthesis of Heterocycles | springerprofessional.de \[springerprofessional.de\]](https://springerprofessional.de)
- [18. pdf.benchchem.com \[pdf.benchchem.com\]](https://pdf.benchchem.com)
- [19. Robust Acenaphthoimidazolylidene Palladium Complexes: Highly Efficient Catalysts for Suzuki-Miyaura Couplings with Sterically Hindered Substrates \[organic-chemistry.org\]](https://organic-chemistry.org)
- [20. An efficient method for sterically demanding Suzuki-Miyaura coupling reactions - PubMed \[pubmed.ncbi.nlm.nih.gov\]](https://pubmed.ncbi.nlm.nih.gov)
- [21. pdf.benchchem.com \[pdf.benchchem.com\]](https://pdf.benchchem.com)

- To cite this document: BenchChem. [Technical Support Center: Accelerating Reactions for Sterically Hindered Cyclohexyl Pyrazoles]. BenchChem, [2026]. [Online PDF]. Available at: [<https://www.benchchem.com/product/b2463420/docs#technical-support-center-accelerating-reactions-for-sterically-hindered-cyclohexyl-pyrazoles>]

Disclaimer & Data Validity:

The information provided in this document is for Research Use Only (RUO) and is strictly not intended for diagnostic or therapeutic procedures. While BenchChem strives to provide accurate protocols, we make no warranties, express or implied, regarding the fitness of this product for every specific experimental setup.

Technical Support: The protocols provided are for reference purposes. Unsure if this reagent suits your experiment?

Need Industrial/Bulk Grade? [Request Custom Synthesis Quote](#)

BenchChem

Our mission is to be the trusted global source of essential and advanced chemicals, empowering scientists and researchers to drive progress in science and industry.

Contact

Address: 3281 E Guasti Rd
Ontario, CA 91761, United States
Phone: (601) 213-4426
Email: info@benchchem.com

[Contact our Ph.D. Support Team for a compatibility check](#)