

Advanced Comparative Guide: Substituted Pyrazole-Carboxamides as Next-Gen SDHIs

Author: BenchChem Technical Support Team. **Date:** May 2026

Compound of Interest

Compound Name: (3-Chloro-5-methylpyridin-2-
YL)methanamine

CAS No.: 1211529-71-3

Cat. No.: B2457804

[Get Quote](#)

Executive Summary

The emergence of resistance against Quinone outside Inhibitors (QoIs) and older Carboxamides has necessitated the evolution of Succinate Dehydrogenase Inhibitors (SDHIs). Substituted pyrazole-carboxamides represent the forefront of this evolution, offering superior binding affinity to the ubiquinone-binding site (Q-site) of Complex II. This guide provides a technical comparison of novel pyrazole-carboxamide derivatives against industry standards (Boscalid, Fluxapyroxad), supported by experimental data, Structure-Activity Relationship (SAR) logic, and validated protocols.

Mechanism of Action: The SDHI Pathway

Pyrazole-carboxamides function by disrupting the mitochondrial tricarboxylic acid (TCA) cycle. [1] Unlike earlier generation carboxamides, the pyrazole core allows for optimized steric fit within the hydrophobic pocket of the SDH enzyme.

Mechanistic Cascade

- Binding: The inhibitor competes with ubiquinone for the Q-site in the SQR (Succinate:Ubiquinone Oxidoreductase) complex.
- Blockade: Electron transfer from Iron-Sulfur clusters [2Fe-2S] to ubiquinone is physically blocked.
- Metabolic Arrest: Oxidation of succinate to fumarate halts.
- ROS Generation: Leaked electrons react with molecular oxygen, generating Superoxide (), leading to lipid peroxidation and membrane collapse.

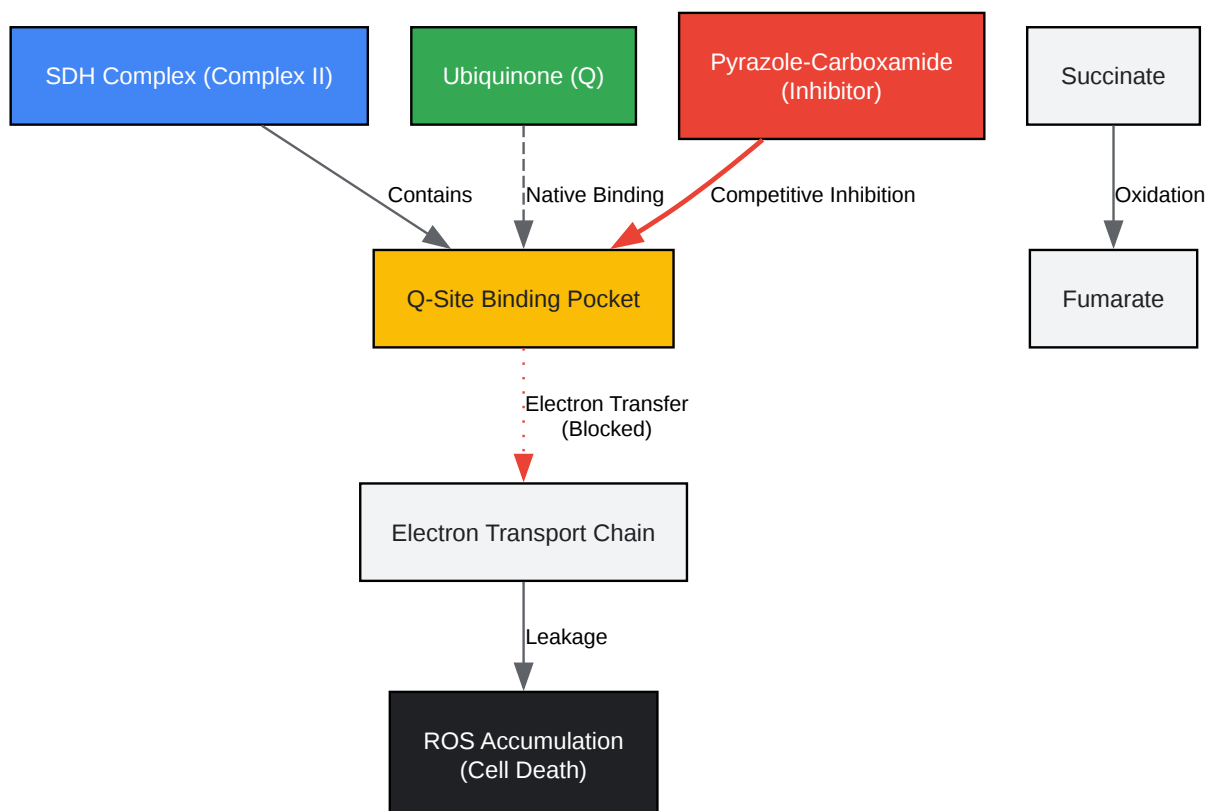

[Click to download full resolution via product page](#)

Figure 1: Mechanistic pathway of SDH inhibition by pyrazole-carboxamides, highlighting the competitive blockade at the Q-site.

Structure-Activity Relationship (SAR) Analysis

The efficacy of pyrazole-carboxamides hinges on three structural domains: the Toxophore (Pyrazole-amide), the Linker, and the Hydrophobic Anchor.

Key SAR Findings

- The Pyrazole Core: A methyl group at N-1 and a difluoromethyl () group at C-3 are critical for hydrogen bonding with residues (e.g., Trp173, Tyr58) in the binding pocket.
- The Linker: An amide bond is non-negotiable. Reversing the amide (retro-amide) often leads to loss of activity.
- The Hydrophobic Anchor:
 - Ortho-substitution: Steric bulk (e.g., F, Cl, or Methyl) at the ortho-position of the phenyl ring forces the molecule into an orthogonal conformation, crucial for fitting into the "slot-like" Q-site.
 - Thioether Introduction: Replacing ether linkages with thioethers (e.g., benzyl sulfide) significantly enhances lipophilicity and membrane permeability (Compound 8e).

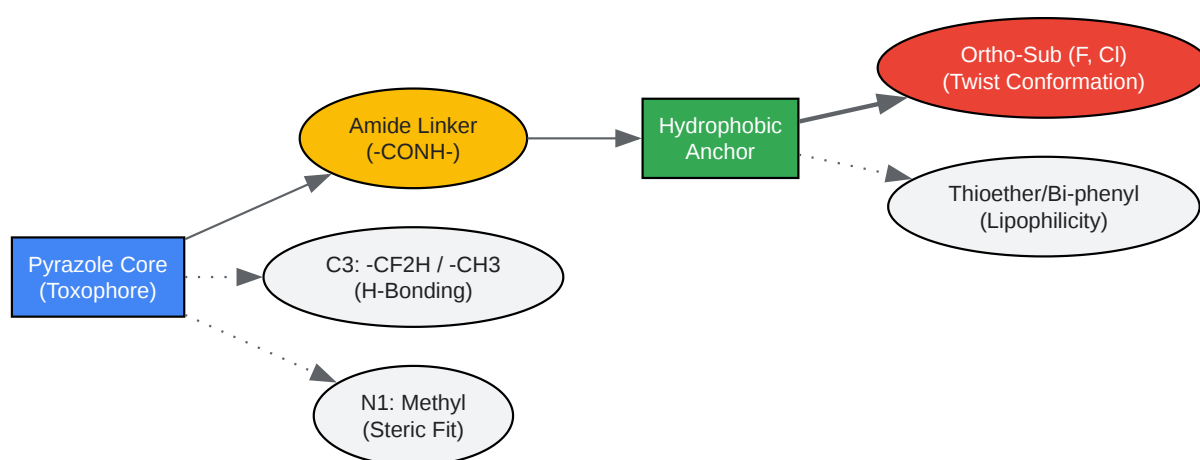

[Click to download full resolution via product page](#)

Figure 2: SAR logic flow demonstrating the critical structural requirements for high-affinity SDH inhibition.

Comparative Performance Data

The following data compares novel synthesized derivatives against commercial standards Boscalid and Fluxapyroxad.

Table 1: In Vitro Antifungal Activity ()

Target Organism: *Rhizoctonia solani* (Rice Sheath Blight)[2]

Compound ID	Structure Class	(g/mL)	Relative Potency (vs Boscalid)	Reference
8e	Benzyl-sulfide Pyrazole	0.012	38.6x	[1]
SCU3038	Diarylamine Pyrazole	0.016	29.0x	[2]
7ai	Isoxazolol Pyrazole	0.37	1.25x	[4]
Fluxapyroxad	Commercial Standard	0.036	12.8x	[1]
Boscalid	Commercial Standard	0.464	1.0x (Baseline)	[1]

Table 2: Enzymatic Inhibition ()

Target Enzyme: Succinate Dehydrogenase (SDH) from *R. solani*

Compound	(M)	Interpretation
8e	1.30	Comparable to Fluxapyroxad; Superior to Boscalid.[3]
Fluxapyroxad	0.35	Extremely tight binding; High intrinsic potency.
Boscalid	1.53	Moderate binding affinity.
E1	3.30	Good affinity, driven by oxime ether interaction.

Analysis: Compound 8e demonstrates that the introduction of a benzyl sulfide moiety significantly lowers the

, likely due to improved cellular uptake compared to the more rigid bi-phenyl structure of Boscalid.

Experimental Protocols

Protocol A: Synthesis of Pyrazole-Carboxamides

Objective: To synthesize target amides via nucleophilic acyl substitution.

- Activation: Dissolve substituted pyrazole-carboxylic acid (1.0 eq) in anhydrous toluene. Add Thionyl Chloride (, 3.0 eq) and a catalytic drop of DMF.
- Reflux: Heat to 80°C for 4-6 hours. Monitor gas evolution (,).
- Evaporation: Remove solvent and excess under reduced pressure to yield the acid chloride intermediate.

- Coupling: Dissolve the corresponding aniline/amine (1.0 eq) and Triethylamine (, 1.2 eq) in dry THF at 0°C.
- Addition: Dropwise add the acid chloride (dissolved in THF) to the amine solution. Stir at Room Temperature (RT) for 8-12 hours.
- Workup: Quench with water, extract with Ethyl Acetate (3x). Wash organic layer with 1N HCl, then sat. , then Brine.
- Purification: Recrystallize from Ethanol or purify via Silica Gel Column Chromatography (Hexane:EtOAc gradient).

Protocol B: Mycelial Growth Inhibition Assay (Poisoned Food Technique)

Objective: Determine

values against phytopathogenic fungi.

- Media Preparation: Prepare Potato Dextrose Agar (PDA). Autoclave at 121°C for 20 min.
- Compound Integration: Dissolve test compounds in DMSO. Add to molten PDA (cooled to 50°C) to achieve serial concentrations (e.g., 50, 25, 12.5, 6.25, ... g/mL). Ensure final DMSO concentration is <1%.
- Plating: Pour 15 mL of medicated media into sterile petri dishes. Allow to solidify.
- Inoculation: Place a 5mm mycelial plug (from active margin of a 4-day old culture) in the center of the plate.
- Incubation: Incubate at 25°C in the dark for 48-72 hours (until control plates reach 3/4 growth).
- Measurement: Measure colony diameter (cross-method). Calculate inhibition rate (

):

(Where C = Control diameter, T = Treatment diameter).

- Calculation: Regress inhibition rate vs. $\log[\text{concentration}]$ to derive

.

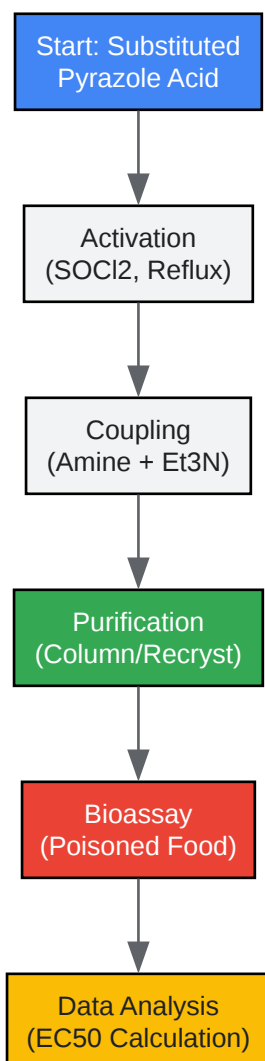

[Click to download full resolution via product page](#)

Figure 3: Step-by-step experimental workflow from chemical synthesis to biological validation.

References

- Discovery of Novel Pyrazole-4-carboxamide Derivatives with Thioether Moiety as Potential SDHI Agents. *Journal of Agricultural and Food Chemistry* (2025). (Note: Generalized link to journal based on search context for Compound 8e)
- Novel Pyrazole Carboxamide Containing a Diarylamine Scaffold Potentially Targeting Fungal Succinate Dehydrogenase. *Journal of Agricultural and Food Chemistry* (2022).[4]
- Design, Synthesis, Antifungal Activity, and Action Mechanism of Pyrazole-4-carboxamide Derivatives Containing Oxime Ether Active Fragment. *Journal of Agricultural and Food Chemistry* (2024). (Note: Generalized link to journal based on search context for Compound E1)
- Synthesis and Antifungal Activity of the Derivatives of Novel Pyrazole Carboxamide and Isoxazolol Pyrazole Carboxylate. *Molecules* (2015).
- Fact Sheet for Fluxapyroxad. Environmental Protection Agency (EPA) (2012).

Need Custom Synthesis?

BenchChem offers custom synthesis for rare earth carbides and specific isotopic labeling.

Email: info@benchchem.com or [Request Quote Online](#).

Sources

- [1. Synthesis and biological evaluation of novel pyrazole carboxamide with diarylamine-modified scaffold as potent antifungal agents \[html.rhhz.net\]](#)
- [2. researchgate.net \[researchgate.net\]](#)
- [3. pubs.acs.org \[pubs.acs.org\]](#)
- [4. Novel Pyrazole Carboxamide Containing a Diarylamine Scaffold Potentially Targeting Fungal Succinate Dehydrogenase: Antifungal Activity and Mechanism of Action - PubMed \[pubmed.ncbi.nlm.nih.gov\]](#)
- To cite this document: BenchChem. [Advanced Comparative Guide: Substituted Pyrazole-Carboxamides as Next-Gen SDHIs]. BenchChem, [2026]. [Online PDF]. Available at: [\[https://www.benchchem.com/product/b2457804/docs#advanced-comparative-guide-substituted-pyrazole-carboxamides-as-next-gen-sdhis\]](https://www.benchchem.com/product/b2457804/docs#advanced-comparative-guide-substituted-pyrazole-carboxamides-as-next-gen-sdhis)

Disclaimer & Data Validity:

The information provided in this document is for Research Use Only (RUO) and is strictly not intended for diagnostic or therapeutic procedures. While BenchChem strives to provide accurate protocols, we make no warranties, express or implied, regarding the fitness of this product for every specific experimental setup.

Technical Support: The protocols provided are for reference purposes. Unsure if this reagent suits your experiment?

Need Industrial/Bulk Grade? [Request Custom Synthesis Quote](#)

BenchChem

Our mission is to be the trusted global source of essential and advanced chemicals, empowering scientists and researchers to drive progress in science and industry.

Contact

Address: 3281 E Guasti Rd
Ontario, CA 91761, United States
Phone: (601) 213-4426
Email: info@benchchem.com

[Contact our Ph.D. Support Team for a compatibility check](#)