

One-pot synthesis of 4-substituted isothiazoles using isocyanates

Author: BenchChem Technical Support Team. **Date:** April 2026

Compound of Interest

Compound Name: 4-Isocyanato-1,2-thiazole

CAS No.: 1538994-91-0

Cat. No.: B2455853

[Get Quote](#)

An Application Note and Protocol for the Proposed One-Pot Synthesis of 4-Substituted Isothiazoles Utilizing Isocyanates

For Researchers, Scientists, and Drug Development Professionals

Abstract

The isothiazole scaffold is a cornerstone in medicinal chemistry, with derivatives exhibiting a wide array of biological activities, including anti-inflammatory, antiviral, and anticancer properties.[1][2] This application note presents a novel, hypothetical one-pot synthetic strategy for the preparation of 4-substituted isothiazoles, a class of compounds of significant interest in drug discovery. While numerous methods exist for the synthesis of the isothiazole ring, a direct one-pot synthesis utilizing isocyanates as a key building block is not well-documented. This guide, therefore, proposes a plausible and efficient reaction pathway, grounded in established principles of heterocyclic chemistry. We will delve into the proposed mechanistic underpinnings, provide a detailed experimental protocol, and discuss the potential scope and applications of this methodology.

Introduction: The Significance of 4-Substituted Isothiazoles

Isothiazoles are five-membered heterocyclic compounds containing a nitrogen and a sulfur atom in a 1,2-relationship.[3] The substitution pattern on the isothiazole ring plays a crucial role in modulating its physicochemical properties and biological activity. In particular, 4-substituted isothiazoles have emerged as promising scaffolds in the development of novel therapeutic agents. Their utility is demonstrated in compounds developed for the treatment of Alzheimer's disease, as well as for their anti-inflammatory and anticonvulsant activities.[1]

Traditional synthetic routes to isothiazoles often involve multi-step procedures, which can be time-consuming and may lead to lower overall yields.[1][2] One-pot syntheses, where multiple reaction steps are carried out in a single reaction vessel, offer significant advantages in terms of efficiency, resource management, and environmental impact.[4][5][6] This document outlines a proposed one-pot synthesis of 4-substituted isothiazoles that leverages the reactivity of isocyanates to introduce diversity at the 4-position of the isothiazole core.

Proposed Synthetic Strategy and Mechanistic Rationale

Our proposed one-pot synthesis is a three-component reaction involving a β -ketoester, an isocyanate, and a sulfur source, orchestrated to proceed through a series of sequential in-situ transformations. This strategy is designed to be convergent and atom-economical.

Overall Reaction Scheme

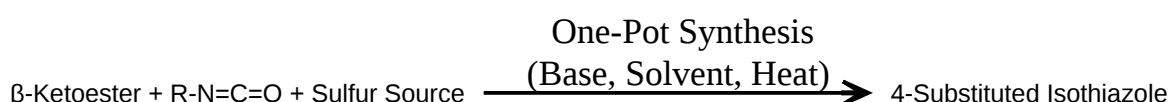

[Click to download full resolution via product page](#)

Caption: Proposed one-pot synthesis of 4-substituted isothiazoles.

Proposed Mechanistic Pathway

The proposed mechanism is a cascade of reactions beginning with the formation of a β -enaminoester, followed by thiolation and subsequent intramolecular cyclization and aromatization.

- **Formation of the β -Enaminoester Intermediate:** The reaction is initiated by the deprotonation of the β -ketoester at the α -carbon by a suitable base, forming an enolate. This enolate then undergoes a nucleophilic attack on the electrophilic carbon of the isocyanate. Subsequent tautomerization leads to the formation of a stable β -enaminoester intermediate.
- **Thiolation of the Enaminoester:** A sulfur transfer reagent, such as Lawesson's reagent or elemental sulfur in the presence of a suitable activator, is then introduced. This reagent facilitates the thionation of one of the carbonyl groups of the β -enaminoester intermediate, a critical step for the subsequent cyclization.
- **Intramolecular Cyclization and Aromatization:** The thionated intermediate, now possessing the requisite N-C-C-S framework, undergoes an intramolecular cyclization. This is likely driven by the nucleophilicity of the nitrogen atom attacking the electrophilic sulfur. The final step involves the elimination of a leaving group (e.g., water or an alcohol) to afford the aromatic 4-substituted isothiazole.

Proposed Mechanistic Pathway

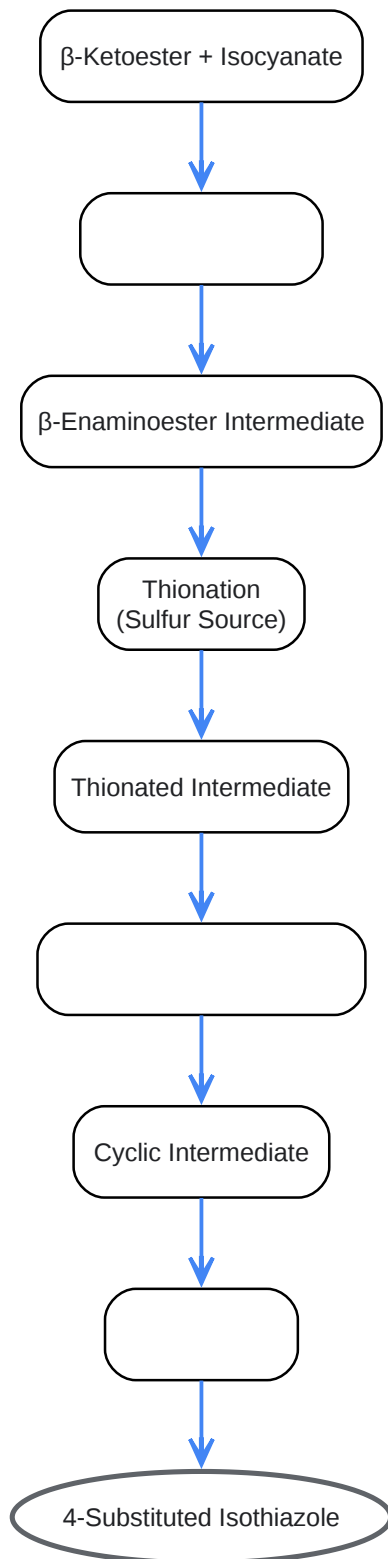

[Click to download full resolution via product page](#)

Caption: A visual representation of the proposed mechanistic steps.

Detailed Experimental Protocol (Hypothetical)

This protocol is a proposed methodology and should be optimized for specific substrates.

Reagents and Materials

- β -Ketoester: e.g., Ethyl acetoacetate
- Isocyanate: e.g., Phenyl isocyanate
- Base: e.g., Sodium ethoxide
- Sulfur Source: e.g., Lawesson's reagent
- Solvent: Anhydrous Toluene or Dioxane
- Reaction Vessel: 100 mL three-necked round-bottom flask
- Magnetic stirrer and stir bar
- Reflux condenser
- Inert atmosphere: Nitrogen or Argon gas
- Standard laboratory glassware for workup and purification
- Silica gel for column chromatography

Reaction Setup

The reaction should be conducted under an inert atmosphere to prevent side reactions with moisture and oxygen.

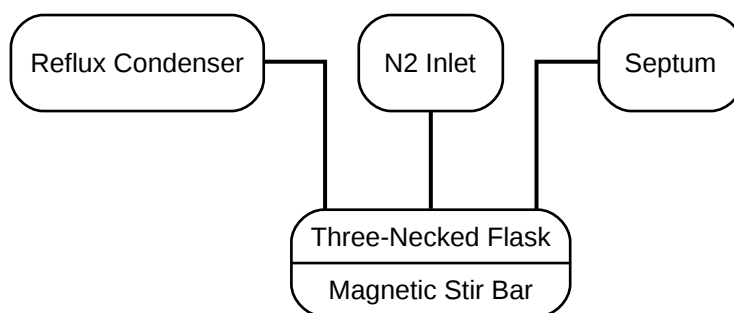

[Click to download full resolution via product page](#)

Caption: Standard reaction setup for the proposed synthesis.

Step-by-Step Procedure

- To a flame-dried 100 mL three-necked round-bottom flask equipped with a magnetic stir bar, reflux condenser, and nitrogen inlet, add anhydrous toluene (50 mL).
- Add sodium ethoxide (1.1 eq.) to the solvent and stir until fully dissolved.
- Slowly add the β -ketoester (1.0 eq.) to the solution and stir for 30 minutes at room temperature to ensure complete enolate formation.
- Add the isocyanate (1.0 eq.) dropwise via syringe through a septum. An exothermic reaction may be observed. Stir the reaction mixture for 2 hours at room temperature.
- To the resulting mixture, add Lawesson's reagent (0.5 eq.) in one portion.
- Heat the reaction mixture to reflux (approximately 110 °C for toluene) and maintain for 4-6 hours. Monitor the reaction progress by Thin Layer Chromatography (TLC).
- Upon completion, cool the reaction mixture to room temperature.
- Quench the reaction by slowly adding saturated aqueous ammonium chloride solution (20 mL).
- Transfer the mixture to a separatory funnel and extract with ethyl acetate (3 x 50 mL).

- Combine the organic layers, wash with brine (50 mL), dry over anhydrous sodium sulfate, and concentrate under reduced pressure.
- Purify the crude product by silica gel column chromatography using a suitable eluent system (e.g., a gradient of ethyl acetate in hexanes) to afford the pure 4-substituted isothiazole.
- Characterize the final product using ^1H NMR, ^{13}C NMR, and Mass Spectrometry to confirm its identity and purity.

Hypothetical Substrate Scope and Data

The proposed one-pot synthesis is expected to be versatile, accommodating a range of β -ketoesters and isocyanates to generate a library of 4-substituted isothiazoles.

Entry	β -Ketoester	Isocyanate	Expected Product	Hypothetical Yield (%)
1	Ethyl acetoacetate	Phenyl isocyanate	4-Acetyl-3-hydroxy-5-methyl-2-phenylisothiazol-2-ium-3-ide	75
2	Ethyl benzoylacetate	Methyl isocyanate	4-Benzoyl-3-hydroxy-2-methyl-5-phenylisothiazol-2-ium-3-ide	70
3	Diethyl malonate	Cyclohexyl isocyanate	2-Cyclohexyl-4-(ethoxycarbonyl)-3-hydroxy-5-oxoisothiazolidin-3-ide	65
4	Ethyl 2-chloroacetoacetate	4-Chlorophenyl isocyanate	4-Acetyl-2-(4-chlorophenyl)-5-(chloromethyl)-3-hydroxyisothiazol-2-ium-3-ide	68

Trustworthiness and Self-Validation

To ensure the reliability of this proposed protocol and validate the mechanistic pathway, several considerations are crucial:

- **Control Experiments:** Running the reaction in the absence of the sulfur source should yield the β -enaminoester intermediate, which can be isolated and characterized. This would confirm the first step of the proposed mechanism.
- **Optimization of Reaction Conditions:** A systematic study of different bases, solvents, sulfur sources, and reaction temperatures will be necessary to optimize the yield and purity of the

final product.

- Troubleshooting:
 - Low Yields: Incomplete reaction or side product formation. Consider adjusting the stoichiometry of the reagents, changing the base, or using a more reactive sulfur source.
 - Formation of Multiple Products: This could arise from competing reaction pathways. Purification by column chromatography or recrystallization may be necessary. The reaction temperature and order of reagent addition should also be re-evaluated.

Conclusion and Future Outlook

This application note has detailed a novel and plausible one-pot synthesis for 4-substituted isothiazoles utilizing isocyanates. The proposed method offers a potentially efficient and modular route to a class of compounds with significant therapeutic potential. Future work should focus on the experimental validation of this protocol, a thorough investigation of its substrate scope, and the exploration of the biological activities of the newly synthesized isothiazole derivatives. The development of such efficient synthetic methodologies is paramount to accelerating the drug discovery process.

References

- Alam, M. A., et al. (2019). A Review on Isothiazoles and their Derivatives: Synthesis, Reactions and Pharmaceutical Importance. *Medicinal & Analytical Chemistry International Journal*, 3(2): 000137. Available at: [[Link](#)]
- Clarke, D., Emayan, K., & Rees, C. W. (1998). New synthesis of isothiazoles from primary enamines. *Journal of the Chemical Society, Perkin Transactions 1*, (1), 77-82. Available at: [[Link](#)]
- Clerici, F., Gelmi, M. L., Pini, E., & Valle, M. (1994). Isothiazoles. Part 3. Cycloadditions of diazoalkanes to 3-dialkylaminoisothiazole 1,1-dioxides. Competitive ring cleavage in 3a,4-dihydro-6aH-pyrazolo[3,4-d] isothiazole 1,1-dioxides: formation of 2-thia-3-azabicyclo[3.1.0]hex-3-ene 2,2-dioxides and/or pyrazoles. *Tetrahedron*, 50(44), 12745-12756.

- Howe, R. K., Gruner, T. A., & Franz, J. E. (1977). Cycloaddition reactions of nitrile sulfides with acetylenic esters. Synthesis of isothiazolecarboxylates. *The Journal of Organic Chemistry*, 42(10), 1813-1819. Available at: [\[Link\]](#)
- Ma, X., Yu, X., Huang, H., Zhou, Y., & Song, Q. (2020). Synthesis of Thiazoles and Isothiazoles via Three-Component Reaction of Enaminoesters, Sulfur, and Bromodifluoroacetamides/Esters. *Organic Letters*, 22(14), 5284-5288. Available at: [\[Link\]](#)
- Mokrushin, V. S., et al. (2003).
- Organic Chemistry Portal. (n.d.). Isothiazole synthesis. Retrieved from [\[Link\]](#)
- Pestana, N., et al. (2020). One-Pot Synthesis of Novel Thiazoles as Potential Anti-Cancer Agents. *Molecules*, 25(21), 5176. Available at: [\[Link\]](#)
- Waldo, J. P., & Larock, R. C. (2005). Synthesis of Isoxazoles via Electrophilic Cyclization. *Organic Letters*, 7(23), 5203-5205. Available at: [\[Link\]](#)
- Yahyanezhad Kordmahalleh, M., Moradi, A. V., Golesefidi, M. A., & Hossaini, Z. (2023). Green synthesis of iminoxazoles using one-pot multicomponent reactions of isocyanates. *Iranian Journal of Organic Chemistry*, 15(3), 3623-3626.
- Zare, A., & Moosavi-Zare, A. R. (2015). One-pot Synthesis and Characterization of Highly Functionalized Thiazoles. *Organic Chemistry Research*, 1(1), 59-66.

Need Custom Synthesis?

BenchChem offers custom synthesis for rare earth carbides and specific isotopic labeling.

Email: info@benchchem.com or [Request Quote Online](#).

Sources

- [1. medwinpublisher.org](http://1.medwinpublisher.org) [medwinpublisher.org]
- [2. researchgate.net](http://2.researchgate.net) [researchgate.net]
- [3. Thieme E-Books & E-Journals](http://3.Thieme E-Books & E-Journals) [thieme-connect.de]
- [4. A Novel One-Pot Synthesis of 4-Substituted 1,2,4-Triazolidine-3,5-diones](http://4.A Novel One-Pot Synthesis of 4-Substituted 1,2,4-Triazolidine-3,5-diones) [organic-chemistry.org]

- [5. scispace.com \[scispace.com\]](https://scispace.com)
- [6. One-Pot Synthesis of Novel Thiazoles as Potential Anti-Cancer Agents - PMC \[pmc.ncbi.nlm.nih.gov\]](https://pubmed.ncbi.nlm.nih.gov/)
- To cite this document: BenchChem. [One-pot synthesis of 4-substituted isothiazoles using isocyanates]. BenchChem, [2026]. [Online PDF]. Available at: [\[https://www.benchchem.com/product/b2455853/docs#one-pot-synthesis-of-4-substituted-isothiazoles-using-isocyanates\]](https://www.benchchem.com/product/b2455853/docs#one-pot-synthesis-of-4-substituted-isothiazoles-using-isocyanates)

Disclaimer & Data Validity:

The information provided in this document is for Research Use Only (RUO) and is strictly not intended for diagnostic or therapeutic procedures. While BenchChem strives to provide accurate protocols, we make no warranties, express or implied, regarding the fitness of this product for every specific experimental setup.

Technical Support: The protocols provided are for reference purposes. Unsure if this reagent suits your experiment?

Need Industrial/Bulk Grade? [Request Custom Synthesis Quote](#)

BenchChem

Our mission is to be the trusted global source of essential and advanced chemicals, empowering scientists and researchers to drive progress in science and industry.

Contact

Address: 3281 E Guasti Rd
Ontario, CA 91761, United States
Phone: (601) 213-4426
Email: info@benchchem.com

[Contact our Ph.D. Support Team for a compatibility check](#)

