

A Comparative Guide to Mass Spectrometry Fragmentation Patterns of Chlorinated Picolinates

Author: BenchChem Technical Support Team. **Date:** April 2026

Compound of Interest

Compound Name:	<i>Methyl 3,5-dichloro-6-hydroxypicolinate</i>
CAS No.:	2368871-72-9
Cat. No.:	B2451816

[Get Quote](#)

This guide offers a detailed comparative analysis of the mass spectrometry fragmentation patterns of chlorinated picolinates, a significant class of herbicides. A thorough understanding of their behavior under mass spectrometric conditions is paramount for the development of robust, sensitive, and specific analytical methods. This document is tailored for researchers, analytical scientists, and professionals in drug development and environmental monitoring who employ mass spectrometry in their work.

Introduction to Chlorinated Picolinates and the Imperative for Accurate Analysis

Chlorinated picolinates, including key compounds like picloram, clopyralid, and aminopyralid, are synthetic auxin herbicides widely used for the control of broadleaf weeds. Due to their persistence and potential to contaminate soil and water resources, regulatory bodies worldwide have established stringent maximum residue limits (MRLs) for these compounds in various matrices. Liquid chromatography coupled with tandem mass spectrometry (LC-MS/MS) has

emerged as the premier analytical technique for their determination, offering unparalleled sensitivity and selectivity.

The core of a successful LC-MS/MS method lies in a deep understanding of the analyte's fragmentation characteristics. The selection of the ionization source, precursor ion, and the optimization of collision energies are critical steps that dictate the specificity and sensitivity of the assay. This guide provides a comparative examination of the fragmentation patterns of prominent chlorinated picolinates, supported by experimental data and elucidating the underlying fragmentation mechanisms.

Ionization and Precursor Ion Selection: The First Step to Specificity

For the analysis of chlorinated picolinates, electrospray ionization (ESI) in the negative ion mode is the technique of choice. The carboxylic acid functional group present in these molecules readily deprotonates in the ESI source, forming a stable $[M-H]^-$ anion, which serves as the precursor ion for subsequent fragmentation analysis.

Experimental Protocol: Precursor Ion Identification

- **Standard Preparation:** A 1 $\mu\text{g/mL}$ standard solution of the target chlorinated picolinate is prepared in a 50:50 (v/v) solution of acetonitrile and water.
- **Direct Infusion:** The standard solution is infused directly into the mass spectrometer's ESI source at a constant flow rate of 5-10 $\mu\text{L/min}$.
- **Full Scan Mass Spectrum Acquisition:** A full scan mass spectrum is acquired in negative ion mode over a mass-to-charge (m/z) range of 50-350.
- **Precursor Ion Confirmation:** The most abundant ion in the spectrum, corresponding to the $[M-H]^-$ species, is identified and selected as the precursor ion for MS/MS experiments.

Compound	Chemical Formula	Exact Mass (Da)	Precursor Ion [M-H] ⁻ (m/z)
Picloram	C ₆ H ₃ Cl ₃ N ₂ O ₂	241.93	239.9
Clopyralid	C ₆ H ₃ Cl ₂ NO ₂	190.96	190.0
Aminopyralid	C ₆ H ₅ Cl ₂ N ₃ O	205.99	205.0

Collision-Induced Dissociation (CID): Unveiling the Fragmentation Fingerprint

Following selection in the first quadrupole, the precursor ion is subjected to collision-induced dissociation (CID) in the collision cell. The energy of the collisions with an inert gas (typically argon) is carefully controlled to induce fragmentation, producing a unique spectrum of product ions that serves as a structural fingerprint for the analyte.

Picloram: A Stepwise Dissociation

The fragmentation of the deprotonated picloram molecule ([M-H]⁻ at m/z 239.9) is initiated by the characteristic neutral loss of CO₂ (44 Da) from the carboxylate group, a common fragmentation pathway for carboxylic acids in negative ion mode, yielding a prominent product ion at m/z 195.9.^[1] A subsequent, higher-energy fragmentation involves the loss of a chlorine atom, resulting in a qualifier ion at m/z 160.9. The transitions 239.9 → 195.9 and 239.9 → 160.9 are highly specific and are commonly used in multiple reaction monitoring (MRM) methods for picloram quantification.

Experimental Protocol: Picloram MS/MS Analysis

- Liquid Chromatography:
 - Column: C18 reversed-phase (e.g., 100 mm x 2.1 mm, 3.5 μm particle size).
 - Mobile Phase A: 0.1% Formic acid in water.
 - Mobile Phase B: 0.1% Formic acid in acetonitrile.
 - Gradient Elution: A linear gradient from 10% to 90% B over 8 minutes.

- Flow Rate: 0.3 mL/min.
- Injection Volume: 5 μ L.
- Tandem Mass Spectrometry (Negative ESI):
 - Capillary Voltage: -3.0 kV.
 - Source Temperature: 150 $^{\circ}$ C.
 - Desolvation Temperature: 400 $^{\circ}$ C.
 - Collision Gas: Argon.
 - MRM Transitions:
 - Quantifier: 239.9 > 195.9 (Collision Energy: 15 eV)
 - Qualifier: 239.9 > 160.9 (Collision Energy: 25 eV)

Picloram Fragmentation Pathway

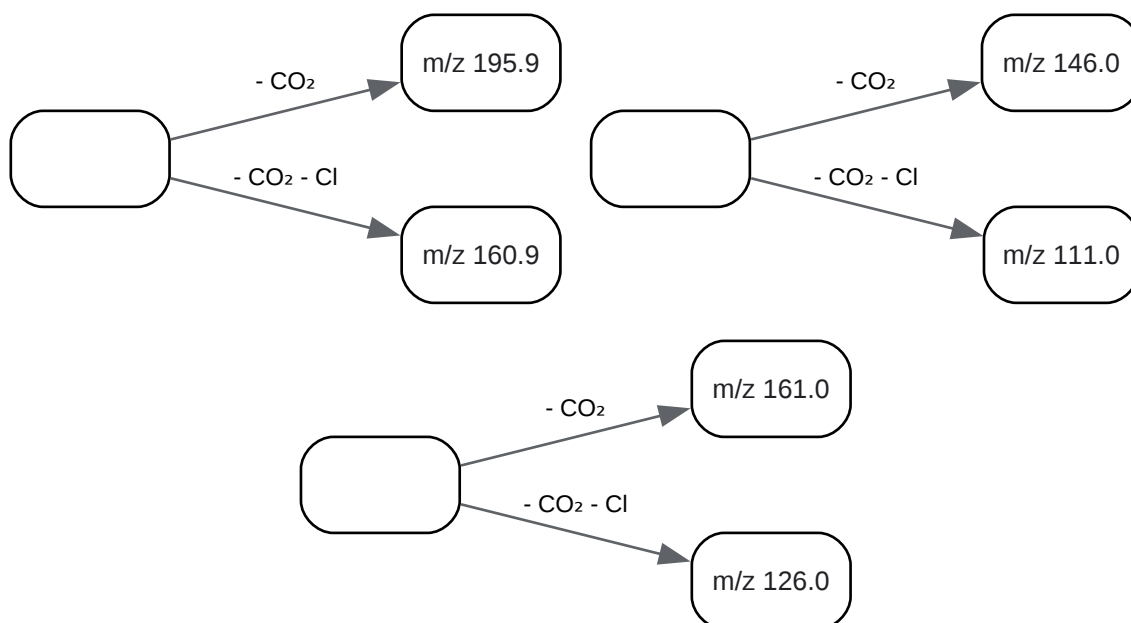

[Click to download full resolution via product page](#)

Need Custom Synthesis?

BenchChem offers custom synthesis for rare earth carbides and specific isotopic labeling.

Email: info@benchchem.com or [Request Quote Online](#).

Sources

- [1. Collision-induced dissociation - Wikipedia \[en.wikipedia.org\]](#)
- To cite this document: BenchChem. [A Comparative Guide to Mass Spectrometry Fragmentation Patterns of Chlorinated Picolinates]. BenchChem, [2026]. [Online PDF]. Available at: [<https://www.benchchem.com/product/b2451816/docs#a-comparative-guide-to-mass-spectrometry-fragmentation-patterns-of-chlorinated-picolinates>]

Disclaimer & Data Validity:

The information provided in this document is for Research Use Only (RUO) and is strictly not intended for diagnostic or therapeutic procedures. While BenchChem strives to provide accurate protocols, we make no warranties, express or implied, regarding the fitness of this product for every specific experimental setup.

Technical Support: The protocols provided are for reference purposes. Unsure if this reagent suits your experiment?

Need Industrial/Bulk Grade? [Request Custom Synthesis Quote](#)

BenchChem

Our mission is to be the trusted global source of essential and advanced chemicals, empowering scientists and researchers to drive progress in science and industry.

Contact

Address: 3281 E Guasti Rd

Ontario, CA 91761, United States

Phone: (601) 213-4426

Email: info@benchchem.com

Contact our Ph.D. Support Team for a compatibility check