

ZL0580 Safety Profile: A Comparative Analysis with Other Epigenetic Modifiers

Author: BenchChem Technical Support Team. **Date:** April 2026

Compound of Interest

Compound Name: ZL0580
Cat. No.: B2450963

[Get Quote](#)

For Researchers, Scientists, and Drug Development Professionals

This guide provides an objective comparison of the safety profile of **ZL0580**, a selective BRD4 inhibitor, with other classes of epigenetic modifiers, including pan-BET inhibitors, histone deacetylase (HDAC) inhibitors, and DNA methyltransferase (DNMT) inhibitors. The information is supported by available preclinical and clinical experimental data to assist researchers in making informed decisions for future studies.

Executive Summary

Epigenetic modifiers are a promising class of therapeutic agents, but their clinical utility is often limited by their safety profiles. **ZL0580**, a selective inhibitor of the first bromodomain (BD1) of BRD4, has demonstrated a favorable preclinical safety profile, particularly when compared to other epigenetic modifiers that exhibit broader target engagement or different mechanisms of action. This guide summarizes key safety-related data, outlines common experimental protocols for toxicity assessment, and provides visual representations of relevant pathways and workflows.

Comparative Safety Data

The following tables summarize the available quantitative data on the cytotoxicity and in vivo toxicity of **ZL0580** and other representative epigenetic modifiers. It is important to note that direct head-to-head comparative studies are limited, and toxicity can be highly dependent on the specific compound, cell line or animal model, and experimental conditions.

Table 1: In Vitro Cytotoxicity of Epigenetic Modifiers

Compound	Class	Cell Line(s)	IC50/CC50 Values	Citation(s)
ZL0580	Selective BRD4 BD1 Inhibitor	SupT1 (T-cell line)	CC50: 11.36 ± 0.55 µM (non-reactivated), 10.89 ± 0.42 µM (reactivated)	[1]
JQ1	Pan-BET Inhibitor	Various cancer cell lines	IC50: 0.28 - 10.36 µM (Ovarian and endometrial cancer)	[2]
MCC cell lines	IC50: ~800 nM	[3]		
Vorinostat (SAHA)	Pan-HDAC Inhibitor	Various cancer cell lines	IC50: ~10 nM (cell-free), 0.146 - 2.697 µM (CTCL cell lines)	[4][5]
Sarcoma cell lines	IC50: 2.0 - 8.6 µM	[6]		
Romidepsin	Class I HDAC Inhibitor	Bladder cancer cell lines	Effective in the nanomolar range	[7]
Panobinostat	Pan-HDAC Inhibitor	Sarcoma cell lines	IC50: 0.02 - 0.1 µM	[6]
Azacitidine	DNMT Inhibitor	OCI-M2 (AML cell line)	IC50: ~1 µM	[8]
Decitabine	DNMT Inhibitor	WIL2-NS (Lymphoblastoid)	Highly genotoxic at 0.2 and 1.0 µM	[9]

Note: IC50 (half-maximal inhibitory concentration) and CC50 (half-maximal cytotoxic concentration) values can vary significantly between different cell lines and assay conditions. The data presented here is for comparative purposes.

Table 2: Preclinical In Vivo Safety of Epigenetic Modifiers

Compound	Class	Animal Model	Key Safety Findings	Citation(s)
ZL0580	Selective BRD4 BD1 Inhibitor	Mice	No evident toxicity at doses up to 300 mg/kg/day for 7 days. No significant changes in body weight, food consumption, or serum biochemistry.	[10]
JQ1	Pan-BET Inhibitor	Mouse xenograft models	Well-tolerated at effective doses (e.g., 50 mg/kg/day).	[11]
Romidepsin	Class I HDAC Inhibitor	Rats and Dogs	Cardiovascular effects (irregular heart rhythm, QTc prolongation), tonic convulsion, tremor at higher doses.	[12]
Mouse xenograft models	No increased acute or late toxicity with ionizing radiation.	[7]		
Panobinostat	Pan-HDAC Inhibitor	Rats and Dogs	Thyroid toxicities, decreased white blood cells and platelets, hemorrhage,	[13]

inflammation,
bone marrow
abnormalities,
testicular
degeneration.

Mouse xenograft models	Significant toxicity at 10 or 20 mg/kg/day.	[14]	
Azacitidine	DNMT Inhibitor	Mouse xenograft model	Lower systemic toxicity with aerosol administration compared to IV, which caused significant myelosuppression. [15]
Decitabine	DNMT Inhibitor	-	High doses are cytotoxic, while lower doses have a hypomethylating effect. [16] Associated with delayed and prolonged myelosuppression.

Signaling Pathways and Experimental Workflows

Mechanism of Action: ZL0580 vs. Pan-BET Inhibitors

ZL0580's selectivity for the BD1 domain of BRD4 is a key differentiator from pan-BET inhibitors like JQ1, which bind to both BD1 and BD2 domains of all BET family proteins. This selectivity may contribute to its distinct biological activity and potentially more favorable safety profile.

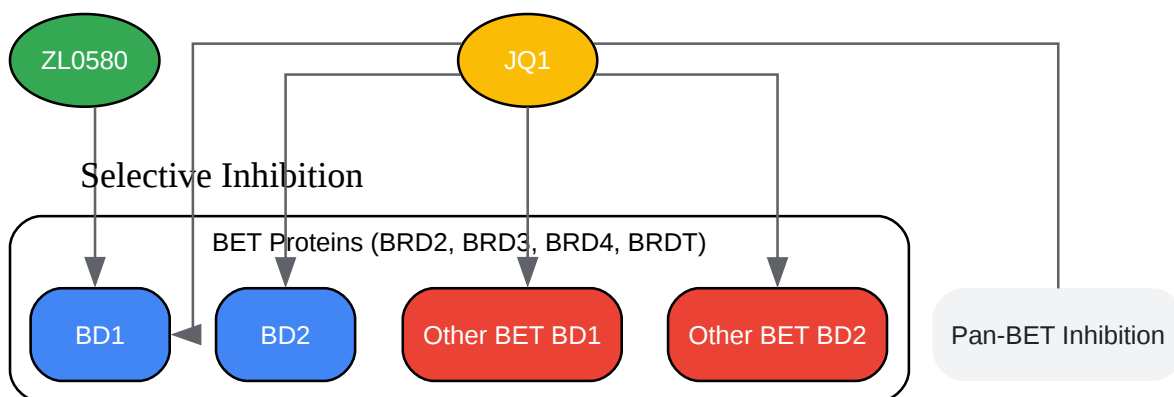

[Click to download full resolution via product page](#)

Figure 1. Differential binding of **ZL0580** and JQ1 to BET bromodomains.

General Workflow for In Vitro Cytotoxicity Assessment

Standard cytotoxicity assays are crucial for determining the concentration-dependent toxicity of a compound on cultured cells.

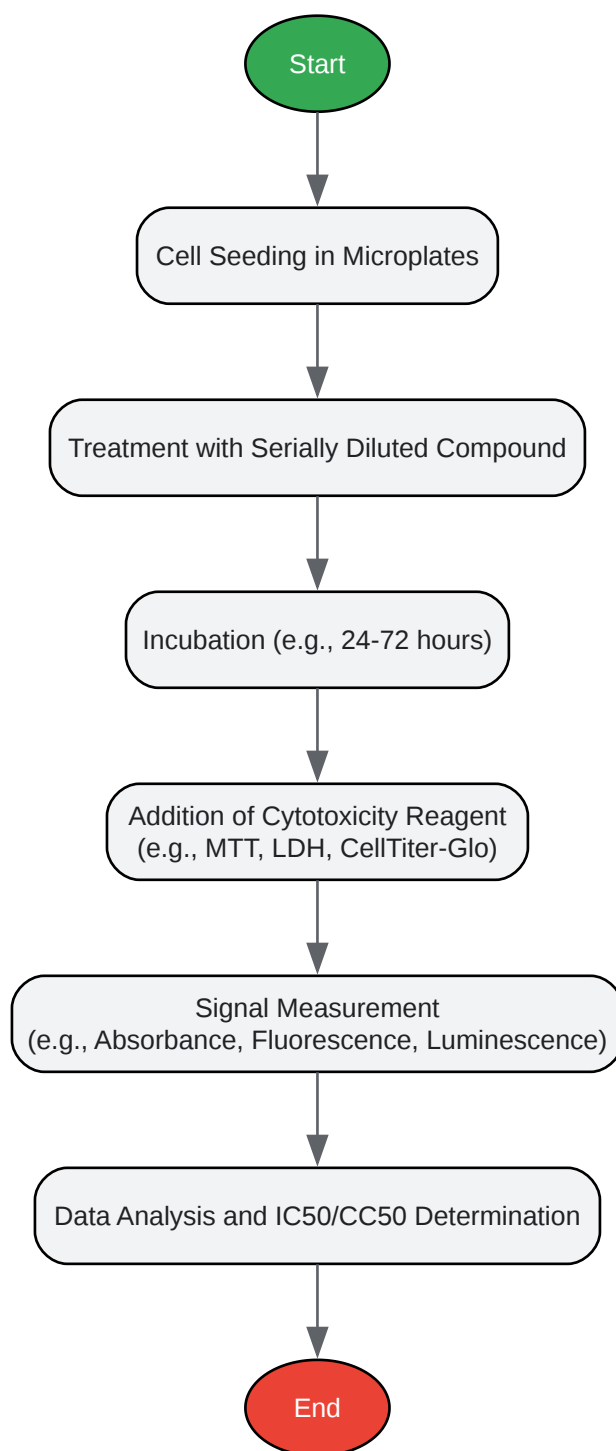

[Click to download full resolution via product page](#)

Need Custom Synthesis?

BenchChem offers custom synthesis for rare earth carbides and specific isotopic labeling.

Email: info@benchchem.com or [Request Quote Online](#).

References

- 1. BRD4 modulator ZL0580 and LEDGINs additively block and lock HIV-1 transcription - PMC [[pmc.ncbi.nlm.nih.gov](https://pubmed.ncbi.nlm.nih.gov/)]
- 2. spandidos-publications.com [spandidos-publications.com]
- 3. BET protein inhibitor JQ1 attenuates Myc-amplified MCC tumor growth in vivo - PMC [[pmc.ncbi.nlm.nih.gov](https://pubmed.ncbi.nlm.nih.gov/)]
- 4. apexbt.com [apexbt.com]
- 5. selleckchem.com [selleckchem.com]
- 6. Histone deacetylase inhibitors vorinostat and panobinostat induce G1 cell cycle arrest and apoptosis in multidrug resistant sarcoma cell lines - PMC [[pmc.ncbi.nlm.nih.gov](https://pubmed.ncbi.nlm.nih.gov/)]
- 7. The Histone Deacetylase Inhibitor Romidepsin Sparing Normal Tissues While Acting as an Effective Radiosensitizer in Bladder Tumors in Vivo - PMC [[pmc.ncbi.nlm.nih.gov](https://pubmed.ncbi.nlm.nih.gov/)]
- 8. Analysis of 5-Azacytidine Resistance Models Reveals a Set of Targetable Pathways - PMC [[pmc.ncbi.nlm.nih.gov](https://pubmed.ncbi.nlm.nih.gov/)]
- 9. Exposure to hypomethylating 5-aza-2'-deoxycytidine (decitabine) causes rapid, severe DNA damage, telomere elongation and mitotic dysfunction in human WIL2-NS cells - PubMed [pubmed.ncbi.nlm.nih.gov]
- 10. An Automated Method to Perform The In Vitro Micronucleus Assay using Multispectral Imaging Flow Cytometry [jove.com]
- 11. selleckchem.com [selleckchem.com]
- 12. accessdata.fda.gov [accessdata.fda.gov]
- 13. accessdata.fda.gov [accessdata.fda.gov]
- 14. Pre-Clinical Study of Panobinostat in Xenograft and Genetically Engineered Murine Diffuse Intrinsic Pontine Glioma Models - PubMed [pubmed.ncbi.nlm.nih.gov]
- 15. Toxicity and Pharmacokinetic Studies of Aerosolized Clinical Grade Azacitidine - PMC [[pmc.ncbi.nlm.nih.gov](https://pubmed.ncbi.nlm.nih.gov/)]
- 16. Evolution of Decitabine Development: Accomplishments, Ongoing Investigations, and Future Strategies - PMC [[pmc.ncbi.nlm.nih.gov](https://pubmed.ncbi.nlm.nih.gov/)]
- To cite this document: BenchChem. [ZL0580 Safety Profile: A Comparative Analysis with Other Epigenetic Modifiers]. BenchChem, [2026]. [Online PDF]. Available at: [<https://www.benchchem.com/product/b2450963/docs#zl0580-safety-profile-a-comparative-analysis-with-other-epigenetic-modifiers>]

Disclaimer & Data Validity:

The information provided in this document is for Research Use Only (RUO) and is strictly not intended for diagnostic or therapeutic procedures. While BenchChem strives to provide accurate protocols, we make no warranties, express or implied, regarding the fitness of this product for every specific experimental setup.

Technical Support: The protocols provided are for reference purposes. Unsure if this reagent suits your experiment?

Need Industrial/Bulk Grade? [Request Custom Synthesis Quote](#)

BenchChem

Our mission is to be the trusted global source of essential and advanced chemicals, empowering scientists and researchers to drive progress in science and industry.

Contact

Address: 3281 E Guasti Rd

Ontario, CA 91761, United States

Phone: (601) 213-4426

Email: info@benchchem.com

[Contact our Ph.D. Support Team for a compatibility check](#)