

METHYL ALPHA-D-GALACTOPYRANOSIDE MONOHYDRATE structure elucidation

Author: BenchChem Technical Support Team. **Date:** May 2026

Compound of Interest

Compound Name:	METHYL ALPHA-D- GALACTOPYRANOSIDE MONOHYDRATE
CAS No.:	34004-14-3
Cat. No.:	B2449512

[Get Quote](#)

An In-Depth Technical Guide to the Structure Elucidation of **METHYL ALPHA-D-GALACTOPYRANOSIDE MONOHYDRATE**

Authored by: A Senior Application Scientist

Introduction: The Significance of Methyl α -D-galactopyranoside Monohydrate

Methyl α -D-galactopyranoside monohydrate is a carbohydrate derivative of significant interest in biochemical and pharmaceutical research. As a methyl glycoside of galactose, it serves as a crucial building block in the synthesis of more complex oligosaccharides and glycoconjugates. [1][2] Its structure allows it to act as a substrate for glycosyltransferases, enzymes pivotal in glycosylation processes, making it an invaluable tool for studying carbohydrate-protein interactions in fields like glycobiology and drug development. [1][3] Furthermore, its applications extend to the food industry as a sweetener and flavoring agent and in cosmetics for its moisturizing properties. [1]

This guide provides a comprehensive, in-depth exploration of the analytical methodologies employed to elucidate and confirm the precise three-dimensional structure of Methyl α -D-galactopyranoside Monohydrate. We will delve into the core techniques of Nuclear Magnetic Resonance (NMR) spectroscopy, Mass Spectrometry (MS), and single-crystal X-ray crystallography, presenting not just the "how" but the critical "why" behind each experimental choice.

Table 1: Physicochemical Properties of Methyl α -D-galactopyranoside Monohydrate

Property	Value	Source
Molecular Formula	$C_7H_{14}O_6 \cdot H_2O$	[1]
Molecular Weight	194.18 g/mol	[1]
Appearance	White to off-white crystalline powder	[1]
Melting Point	106-110 °C	[1]
Optical Rotation	$[\alpha]_{20/D} = +173^\circ$ to $+183^\circ$ (c=1 in H_2O)	[1]
Solubility	Soluble in water, methanol, and hot ethanol	[2]

The Overall Strategy: A Multi-faceted Approach to Structural Verification

The complete and unambiguous structure elucidation of a molecule like Methyl α -D-galactopyranoside Monohydrate relies on a synergistic application of multiple analytical techniques. Each method provides a unique piece of the structural puzzle, and their combined data create a self-validating system. Our approach is hierarchical, starting with the most information-rich solution-state technique (NMR) to define the covalent framework and stereochemistry, followed by mass spectrometry to confirm the molecular weight and elemental composition, and culminating in X-ray crystallography for the definitive solid-state structure.

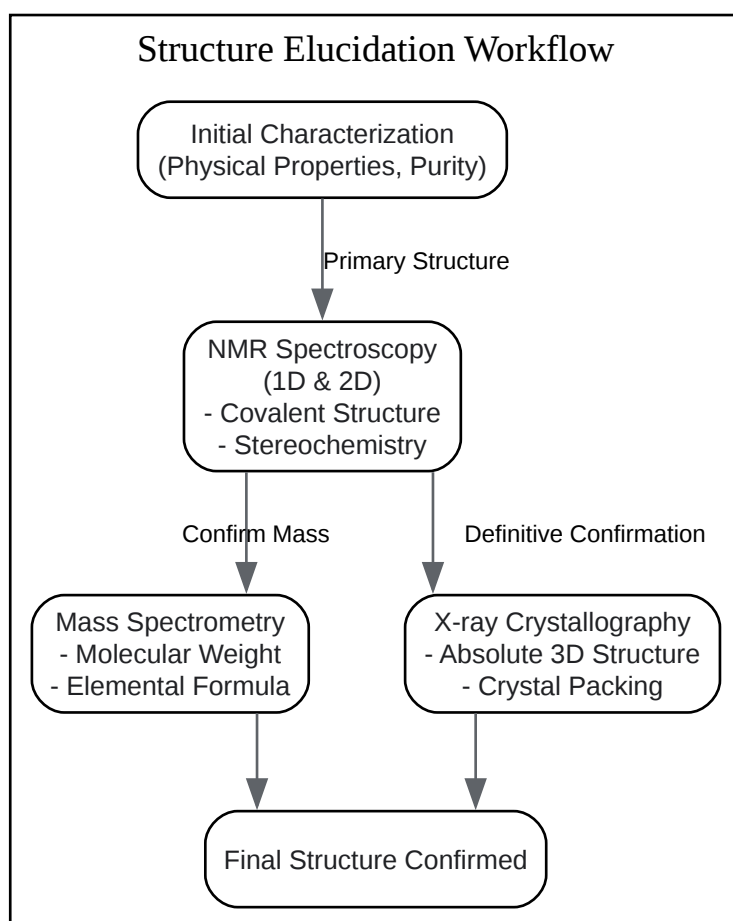

[Click to download full resolution via product page](#)

Caption: Overall workflow for the structure elucidation of Methyl α -D-galactopyranoside Monohydrate.

Part 1: Nuclear Magnetic Resonance (NMR) Spectroscopy - The Blueprint of the Molecule

NMR spectroscopy is the cornerstone of structural analysis for organic molecules in solution, and it is particularly powerful for carbohydrates.^[4] By probing the magnetic properties of atomic nuclei (primarily ^1H and ^{13}C), we can map out the connectivity of atoms and their spatial relationships.

^1H and ^{13}C NMR: Assigning the Core Structure

One-dimensional ^1H and ^{13}C NMR spectra provide the initial, detailed view of the molecule's framework. For carbohydrates, the dispersion of proton signals can be limited, often falling within a narrow range of the spectrum, which makes definitive assignment from a 1D spectrum alone challenging.[4] However, key regions are highly informative. The anomeric proton (H1), for instance, typically resonates at a distinct downfield chemical shift.[5]

Table 2: Expected ^1H and ^{13}C Chemical Shifts for Methyl α -D-galactopyranoside in D_2O

Atom	^1H Chemical Shift (ppm)	^{13}C Chemical Shift (ppm)
1	~4.8	~100.5
2	~3.8	~69.0
3	~3.7	~70.0
4	~3.9	~70.5
5	~4.0	~71.5
6	~3.7	~62.0
OCH_3	~3.4	~56.0

Note: These are approximate values; actual shifts can vary with solvent and temperature.

The ^{13}C NMR spectrum offers better signal dispersion, with the anomeric carbon (C1) appearing around 100 ppm and the other ring carbons resonating between 60 and 80 ppm.[6] The methyl group carbon of the glycoside provides a distinct signal at approximately 56 ppm.

2D NMR: Connecting the Dots

To overcome the signal overlap in the ^1H NMR spectrum and to definitively link protons to their corresponding carbons and to each other, a suite of two-dimensional NMR experiments is essential.

- COSY (Correlation Spectroscopy): This experiment reveals proton-proton couplings, allowing us to "walk" around the pyranose ring by identifying adjacent protons.[7] For example, the H1 signal will show a correlation to the H2 signal, H2 to H3, and so on.

- HSQC (Heteronuclear Single Quantum Coherence): HSQC correlates each proton signal with the carbon to which it is directly attached.^[7] This is the most reliable way to assign the carbon signals based on the less-overlapped proton signals.
- HMBC (Heteronuclear Multiple Bond Correlation): This experiment shows correlations between protons and carbons that are two or three bonds away.^[7] A key correlation for this molecule is between the protons of the methyl group (-OCH₃) and the anomeric carbon (C1), definitively proving the site of glycosylation.

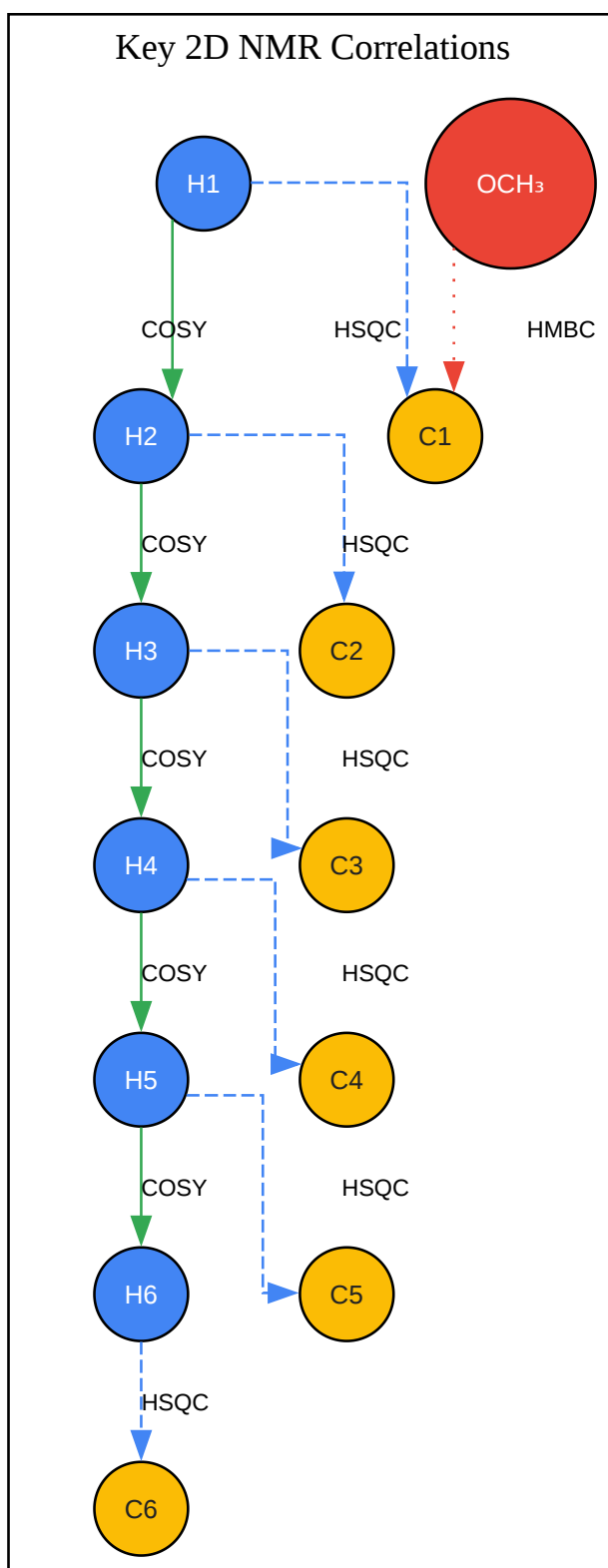

[Click to download full resolution via product page](#)

Caption: Diagram of key 2D NMR correlations for structural assignment.

Experimental Protocol: NMR Analysis

- **Sample Preparation:** Dissolve approximately 10 mg of Methyl α -D-galactopyranoside Monohydrate in 0.6 mL of deuterium oxide (D_2O).^[6] Ensure the sample is fully dissolved.
- **Instrument Setup:** Use a high-field NMR spectrometer (e.g., 500 MHz or higher) for optimal resolution.^[6] Tune and match the probe for both 1H and ^{13}C frequencies.
- **1D Spectra Acquisition:** Acquire a standard 1H spectrum and a proton-decoupled ^{13}C spectrum.
- **2D Spectra Acquisition:** Sequentially acquire COSY, HSQC, and HMBC spectra using standard instrument parameters. Typical acquisition times can range from a few hours for COSY and HSQC to several hours for HMBC, depending on the sample concentration.^[6]
- **Data Processing and Analysis:** Process the spectra using appropriate software (e.g., MestReNova, TopSpin). Use the HSQC to assign the carbons, the COSY to establish the proton spin system of the pyranose ring, and the HMBC to confirm long-range connectivities, especially the crucial OCH_3 to C1 link.

Part 2: Mass Spectrometry - Confirming the Mass and Composition

Mass spectrometry (MS) is a powerful technique for determining the molecular weight of a compound and can provide valuable structural information through analysis of fragmentation patterns.^[6] For a glycoside, MS is critical for confirming the mass of the intact molecule and observing the characteristic cleavage of the glycosidic bond.

Ionization and Mass Determination

Soft ionization techniques like Electrospray Ionization (ESI) or Matrix-Assisted Laser Desorption/Ionization (MALDI) are ideal for analyzing carbohydrates as they minimize in-source fragmentation and allow for the observation of the intact molecular ion.^[6] For Methyl α -D-galactopyranoside Monohydrate ($C_7H_{14}O_6 \cdot H_2O$, MW = 212.19 g/mol including water, 194.18 g/mol anhydrous), we expect to observe the protonated molecule $[M+H]^+$ or adducts such as $[M+Na]^+$. High-resolution mass spectrometry (HRMS) can provide a highly accurate mass measurement, which helps to confirm the elemental composition.

Fragmentation Analysis (MS/MS)

Tandem mass spectrometry (MS/MS) involves selecting the molecular ion and subjecting it to fragmentation. The most common fragmentation pathway for glycosides is the cleavage of the glycosidic bond, resulting in the loss of the sugar moiety.^{[8][9]} In the case of Methyl α -D-galactopyranoside, this would involve the loss of the methyl galactoside as a neutral entity or the formation of characteristic fragment ions.

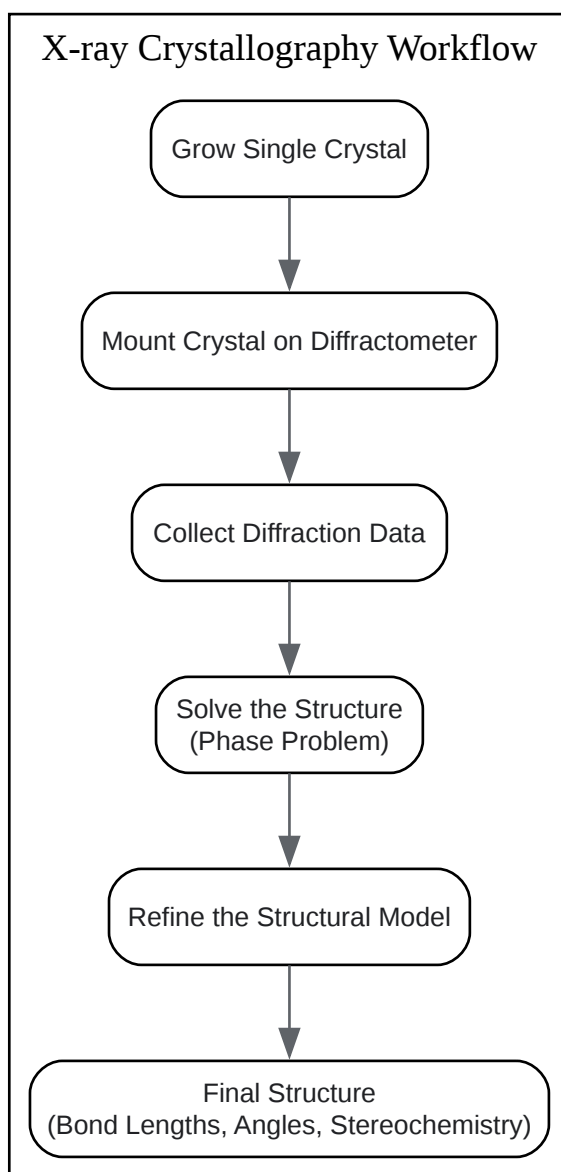
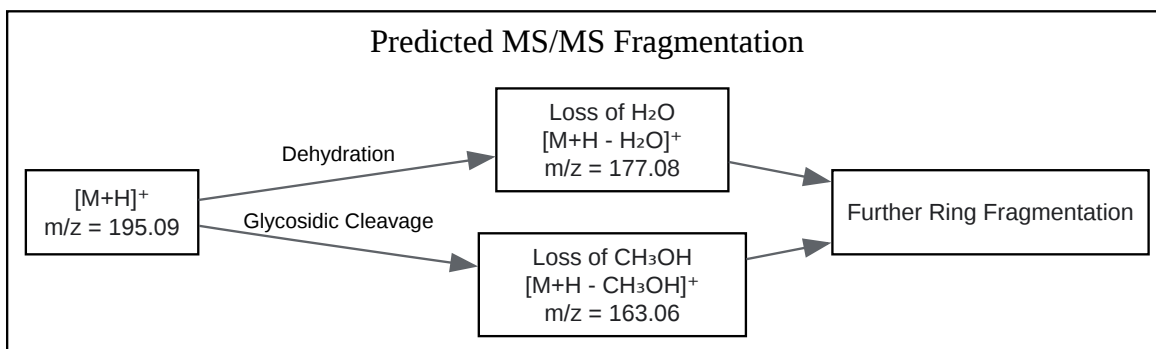

[Click to download full resolution via product page](#)

Need Custom Synthesis?

BenchChem offers custom synthesis for rare earth carbides and specific isotopic labeling.

Email: info@benchchem.com or [Request Quote Online](#).

Sources

- 1. Glycoprotein N-glycan preparation for MS analysis | National Center for Functional Glycomics (NCFG) [research.bidmc.org]
- 2. pubs.acs.org [pubs.acs.org]
- 3. par.nsf.gov [par.nsf.gov]
- 4. osti.gov [osti.gov]
- 5. Determination of Flavonoid Glycosides by UPLC-MS to Authenticate Commercial Lemonade - PMC [pmc.ncbi.nlm.nih.gov]
- 6. Nuclear magnetic resonance spectroscopy of carbohydrates - Wikipedia [en.wikipedia.org]
- 7. 7) Common 2D (COSY, HSQC, HMBC) | SDSU NMR Facility – Department of Chemistry [nmr.sdsu.edu]
- 8. spectrabase.com [spectrabase.com]
- 9. spectroscopyonline.com [spectroscopyonline.com]
- To cite this document: BenchChem. [METHYL ALPHA-D-GALACTOPYRANOSIDE MONOHYDRATE structure elucidation]. BenchChem, [2026]. [Online PDF]. Available at: [<https://www.benchchem.com/product/b2449512/docs#methyl-alpha-d-galactopyranoside-monohydrate-structure-elucidation>]

Disclaimer & Data Validity:

The information provided in this document is for Research Use Only (RUO) and is strictly not intended for diagnostic or therapeutic procedures. While BenchChem strives to provide accurate protocols, we make no warranties, express or implied, regarding the fitness of this product for every specific experimental setup.

Technical Support: The protocols provided are for reference purposes. Unsure if this reagent suits your experiment?

Need Industrial/Bulk Grade? [Request Custom Synthesis Quote](#)

BenchChem

Our mission is to be the trusted global source of essential and advanced chemicals, empowering scientists and researchers to drive progress in science and industry.

Contact

Address: 3281 E Guasti Rd
Ontario, CA 91761, United States
Phone: (601) 213-4426
Email: info@benchchem.com

[Contact our Ph.D. Support Team for a compatibility check](#)