

# Technical Guide: GC-MS Fragmentation & Characterization of 4-Tert-butyl-3-methoxybenzaldehyde

**Author:** BenchChem Technical Support Team. **Date:** April 2026

## Compound of Interest

Compound Name:	4-Tert-butyl-3-methoxybenzaldehyde
CAS No.:	1017060-05-7
Cat. No.:	B2447430

[Get Quote](#)

## Executive Summary

**4-Tert-butyl-3-methoxybenzaldehyde** (CAS: 1017060-05-7) is a sterically hindered aromatic aldehyde often encountered as a synthesis intermediate or functional fragrance component.<sup>[1]</sup> Its analysis requires precise differentiation from regioisomers (e.g., 3-tert-butyl-4-methoxybenzaldehyde) and precursors (e.g., 4-tert-butyl-3-methoxytoluene).

This guide provides a definitive fragmentation map, a validated GC-MS protocol, and a comparative analysis against common structural alternatives.

## Structural & Physical Basis

Before interpreting the mass spectrum, the structural moieties must be understood as fragmentation triggers.

Feature	Moiety	Mass Contribution	Primary Fragmentation Behavior
Core	Benzene Ring	76-78 Da	Stable; produces tropylium/phenyl ions (m/z 77, 91).
Substituent 1	Tert-butyl (-C(CH <sub>3</sub> ) <sub>3</sub> )	57 Da	Dominant: Homolytic cleavage of a methyl group to form a stable quinoid cation ([M-15] <sup>+</sup> ).
Substituent 2	Methoxy (-OCH <sub>3</sub> )	31 Da	Loss of methyl radical (rare) or formaldehyde (CH <sub>2</sub> O) via rearrangement.
Substituent 3	Aldehyde (-CHO)	29 Da	-cleavage (loss of H•) or loss of formyl radical (CHO•).
Total MW	C <sub>12</sub> H <sub>16</sub> O <sub>2</sub>	192.25 g/mol	Molecular Ion (M <sup>+</sup> ) = 192

## GC-MS Experimental Protocol

To reproduce the fragmentation patterns described below, the following method parameters are recommended. This protocol ensures sufficient separation from isomers and minimizes thermal degradation.

### Sample Preparation

- Solvent: Dichloromethane (DCM) or Methanol (HPLC Grade).
- Concentration: 100 µg/mL (100 ppm).

- Derivatization: Not required for this aldehyde, but oximation (using hydroxylamine) can be used if peak tailing is excessive.

## Instrument Parameters

Parameter	Setting	Rationale
Column	5%-Phenyl-methylpolysiloxane (e.g., DB-5MS, HP-5)	Standard non-polar phase separates aromatic isomers by boiling point/polarity.
Dimensions	30 m × 0.25 mm × 0.25 μm	Optimal balance of resolution and capacity.
Carrier Gas	Helium @ 1.0 mL/min (Constant Flow)	Standard carrier for consistent retention times.
Inlet Temp	250°C	Ensures rapid volatilization without pyrolysis.
Oven Program	60°C (1 min) → 15°C/min → 280°C (3 min)	Slow ramp allows separation of co-eluting isomers.
Ion Source	Electron Ionization (EI), 70 eV	Standard energy for library-matchable spectra.
Source Temp	230°C	Prevents condensation of high-boiling aromatics.
Scan Range	m/z 40 – 350	Covers all relevant fragments and potential dimers.

## Fragmentation Analysis (Mechanism & Pattern)[2]

The mass spectrum of **4-tert-butyl-3-methoxybenzaldehyde** is dominated by the stability of the tert-butyl cation and the aromatic ring.

### Primary Ions

- Molecular Ion (M<sup>+</sup>): m/z 192
  - Intensity: Moderate to Strong (20-40%).

- Origin: The aromatic ring stabilizes the radical cation, allowing the intact molecule to survive ionization.
- Base Peak:  $m/z$  177 ( $[M - 15]^+$ )
  - Intensity: 100% (Base Peak).
  - Mechanism: Benzylic/Tert-butyl Cleavage. The loss of a methyl radical ( $\bullet\text{CH}_3$ ) from the tert-butyl group is energetically favored. It relieves steric strain and forms a highly resonance-stabilized cation (involving the methoxy oxygen lone pairs).
  - Diagnostic Value: The dominance of the M-15 peak is the hallmark of tert-butyl substituted aromatics.
- Aldehydic Cleavage:  $m/z$  191 ( $[M - 1]^+$ )
  - Intensity: Weak (<10%).
  - Mechanism: Loss of the aldehydic hydrogen.[2] Common in benzaldehydes but suppressed here by the dominant tert-butyl fragmentation.
- Secondary Fragmentation:  $m/z$  149
  - Intensity: Moderate (10-30%).
  - Mechanism:  $[M - 15 - 28]^+$ . The  $m/z$  177 ion ejects a molecule of Carbon Monoxide (CO), a common pathway for phenolic/methoxy aromatic cations.
- Formyl Loss:  $m/z$  163 ( $[M - 29]^+$ )
  - Intensity: Weak.
  - Mechanism: Direct loss of the  $\text{CHO}\bullet$  radical from the molecular ion.[3]

## Visualizing the Pathway

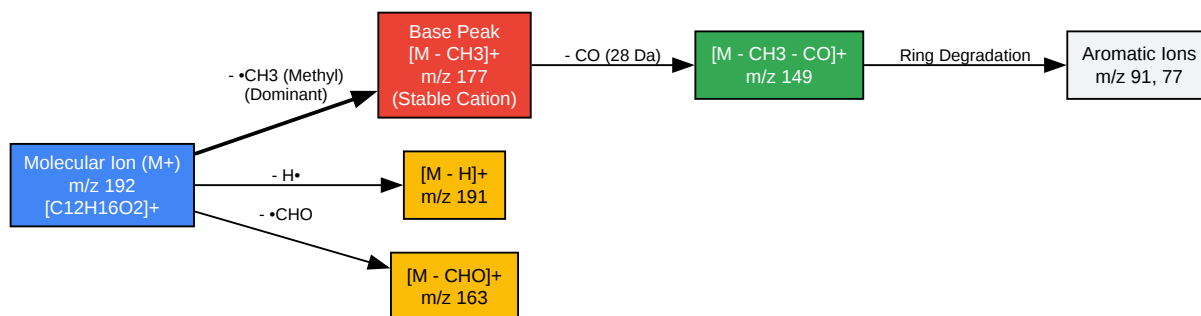

[Click to download full resolution via product page](#)

Figure 1: Proposed fragmentation pathway for **4-Tert-butyl-3-methoxybenzaldehyde** under 70 eV EI.

## Comparative Performance: Target vs. Alternatives

In drug development and synthesis, this compound must be distinguished from its regioisomer (3-tert-butyl-4-methoxybenzaldehyde) and its demethylated precursor (Phenol).

## Comparison Table

Compound	Structure Note	Molecular Ion (m/z)	Base Peak (m/z)	Key Distinguishing Feature
Target: 4-Tert-butyl-3-methoxybenzaldehyde	t-Butyl @ 4, OMe @ 3	192	177	M-15 is dominant. Strong m/z 149 (CO loss).
Alternative A: 3-Tert-butyl-4-methoxybenzaldehyde	t-Butyl @ 3, OMe @ 4	192	177	Very similar MS. Retention Time is key (Ortho-substituted usually elutes earlier). Ortho-effect may enhance m/z 161 (loss of OMe).
Alternative B: 4-Tert-butylbenzaldehyde	No Methoxy	162	147	Mass shift of -30 Da. Missing m/z 177 entirely.
Alternative C: 4-Tert-butyl-3-methoxytoluene	Methyl instead of Aldehyde	178	163	M+ is 178. Base peak 163. No loss of CO (28) from aldehyde.

## Differentiation Strategy

- Mass Shift Check: If M+ is 162, you have the non-methoxylated impurity. If M+ is 178, you have the reduced toluene precursor.
- Isomer Resolution: The target (4-t-butyl) and Alternative A (3-t-butyl) are isomers.
  - MS Logic: Both show m/z 177. However, ortho isomers (Alternative A) often show a distinctive  $[M - 31]^+$  (loss of methoxy) or  $[M - 33]^+$  (loss of methanol + H) due to proximity effects with the aldehyde, which are less favored in the target (meta/para relationship).

- Chromatography: Rely on the Retention Index (RI).[4] The 3,4-substituted pattern usually has a higher boiling point/RI than the 4,3-isomer due to packing efficiency, but experimental verification with a standard is recommended.

## Analytical Workflow

This self-validating workflow ensures accurate identification.

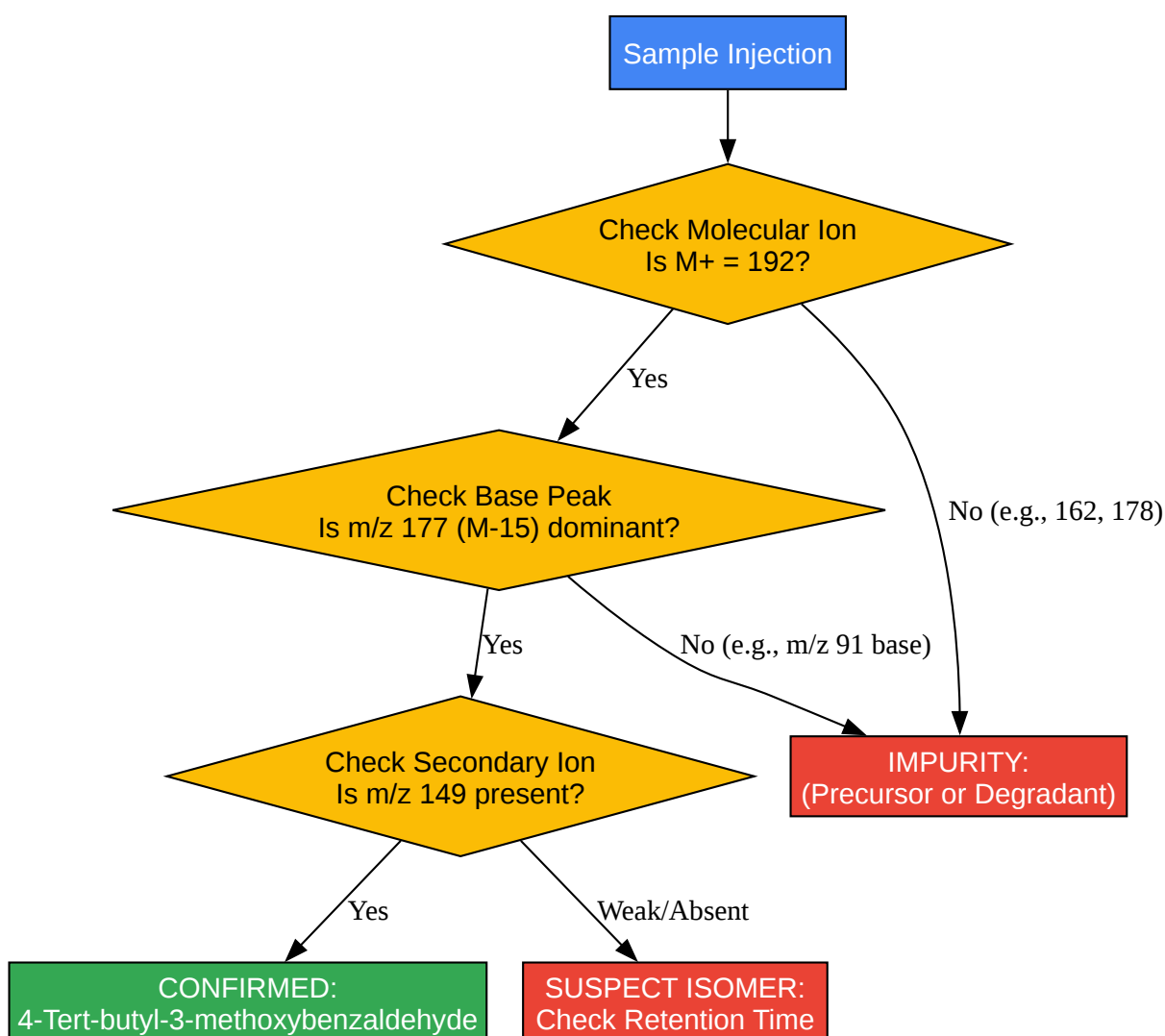

[Click to download full resolution via product page](#)

Figure 2: Decision tree for GC-MS identification.

## References

- PubChem.4-tert-Butylbenzaldehyde Compound Summary. National Center for Biotechnology Information. Available at: [\[Link\]](#) (Accessed March 5, 2026).
- NIST Chemistry WebBook.Benzaldehyde, 3-methoxy- Mass Spectrum. National Institute of Standards and Technology. Available at: [\[Link\]](#) (Accessed March 5, 2026).
- ChemSrc.**4-Tert-butyl-3-methoxybenzaldehyde** CAS 1017060-05-7.[1] Available at: [\[Link\]](#) (Accessed March 5, 2026).
- McLafferty, F. W., & Tureček, F. (1993). Interpretation of Mass Spectra (4th ed.). University Science Books. (Standard text for fragmentation mechanisms of tert-butyl and carbonyl groups).

### Need Custom Synthesis?

BenchChem offers custom synthesis for rare earth carbides and specific isotopic labeling.

Email: [info@benchchem.com](mailto:info@benchchem.com) or [Request Quote Online](#).

## Sources

- 1. 4-(1,1-dimethylethyl)-3-(methoxy)benzaldehyde - CAS号 1017060-05-7 - 摩熵化学 [\[molaid.com\]](#)
- 2. C7H6O C6H5CHO mass spectrum of benzaldehyde fragmentation pattern of m/z m/e ions for analysis and identification of benzaldehyde image diagram doc brown's advanced organic chemistry revision notes [\[docbrown.info\]](#)
- 3. [pdf.benchchem.com](#) [\[pdf.benchchem.com\]](#)
- 4. [lcms.cz](#) [\[lcms.cz\]](#)
- To cite this document: BenchChem. [Technical Guide: GC-MS Fragmentation & Characterization of 4-Tert-butyl-3-methoxybenzaldehyde]. BenchChem, [2026]. [Online]

PDF]. Available at: [<https://www.benchchem.com/product/b2447430/docs#technical-guide-gc-ms-fragmentation-characterization-of-4-tert-butyl-3-methoxybenzaldehyde>]

### Disclaimer & Data Validity:

The information provided in this document is for Research Use Only (RUO) and is strictly not intended for diagnostic or therapeutic procedures. While BenchChem strives to provide accurate protocols, we make no warranties, express or implied, regarding the fitness of this product for every specific experimental setup.

**Technical Support:** The protocols provided are for reference purposes. Unsure if this reagent suits your experiment?

**Need Industrial/Bulk Grade?** [Request Custom Synthesis Quote](#)

## BenchChem

Our mission is to be the trusted global source of essential and advanced chemicals, empowering scientists and researchers to drive progress in science and industry.

### Contact

Address: 3281 E Guasti Rd  
Ontario, CA 91761, United States  
Phone: (601) 213-4426  
Email: [info@benchchem.com](mailto:info@benchchem.com)

[Contact our Ph.D. Support Team for a compatibility check](#)