

# A Comparative Guide to the Mass Spectrometry Fragmentation of Halogenated Benzoyl Chlorides

**Author:** BenchChem Technical Support Team. **Date:** May 2026

## Compound of Interest

|                |  |
|----------------|--|
| Compound Name: | <i>3-Bromo-2-fluoro-5-methylbenzoyl chloride</i> |
| CAS No.:       | 1499840-13-9                                     |
| Cat. No.:      | B2445418   |

[Get Quote](#)

For researchers and professionals in drug development and chemical synthesis, the unambiguous identification of reactive intermediates is paramount. Acyl chlorides, particularly those with complex halogenation patterns, are a class of compounds where detailed structural elucidation is critical. This guide provides an in-depth analysis of the expected electron ionization (EI) mass spectrometry fragmentation pattern of **3-Bromo-2-fluoro-5-methylbenzoyl chloride**. To provide a tangible and practical comparison, its fragmentation behavior will be contrasted with the experimentally-derived fragmentation pattern of a structurally related and commercially available alternative, 3-Bromobenzoyl chloride.

## Theoretical Fragmentation Analysis: 3-Bromo-2-fluoro-5-methylbenzoyl chloride

**3-Bromo-2-fluoro-5-methylbenzoyl chloride** (C<sub>8</sub>H<sub>5</sub>BrClFO, Monoisotopic Mass: 249.91963 Da) is a polysubstituted aromatic acyl chloride.[1] Its fragmentation pattern under electron ionization is dictated by the relative bond strengths and the stability of the resulting fragments.

The presence of three different halogens (Br, F, Cl) and a methyl group on the benzene ring leads to a complex and informative fragmentation cascade.

The initial event in EI-MS is the removal of an electron to form the molecular ion ( $M^+$ ).<sup>[2]</sup> Due to the presence of both bromine (isotopes  $^{79}\text{Br}$  and  $^{81}\text{Br}$  in a ~1:1 ratio) and chlorine (isotopes  $^{35}\text{Cl}$  and  $^{37}\text{Cl}$  in a ~3:1 ratio), the molecular ion region will exhibit a characteristic isotopic cluster.<sup>[3][4]</sup> The molecular ion itself may be of low abundance, a common trait for acyl chlorides which are prone to rapid fragmentation.<sup>[5]</sup>

The most probable primary fragmentation pathways are governed by the cleavage of the weakest bonds and the formation of stable carbocations.

Key Predicted Fragmentation Pathways:

- **Loss of Chlorine Radical:** The C-Cl bond of the benzoyl chloride is labile. Its cleavage results in the formation of the 3-bromo-2-fluoro-5-methylbenzoyl cation (an acylium ion). This is often a very prominent peak in the mass spectra of benzoyl chlorides.<sup>[6]</sup>
- **Loss of Bromine Radical:** Cleavage of the C-Br bond from the aromatic ring is another primary fragmentation event. The stability of the resulting aryl cation influences the intensity of this peak.<sup>[3]</sup>
- **Sequential Loss of CO:** The acylium ion formed from the loss of chlorine can further fragment by losing a neutral carbon monoxide (CO) molecule. This is a characteristic fragmentation of carbonyl compounds.<sup>[2]</sup>
- **Loss of the Acyl Group:** Fragmentation can also involve the loss of the entire -COCl group to generate a substituted phenyl cation.
- **Other Fragmentations:** Minor fragmentation pathways could include the loss of a fluorine radical or a methyl radical, although these are generally less favored compared to the loss of chlorine or bromine.

The following diagram illustrates the predicted primary fragmentation pathways for **3-Bromo-2-fluoro-5-methylbenzoyl chloride**.

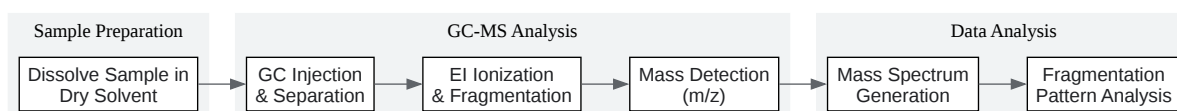
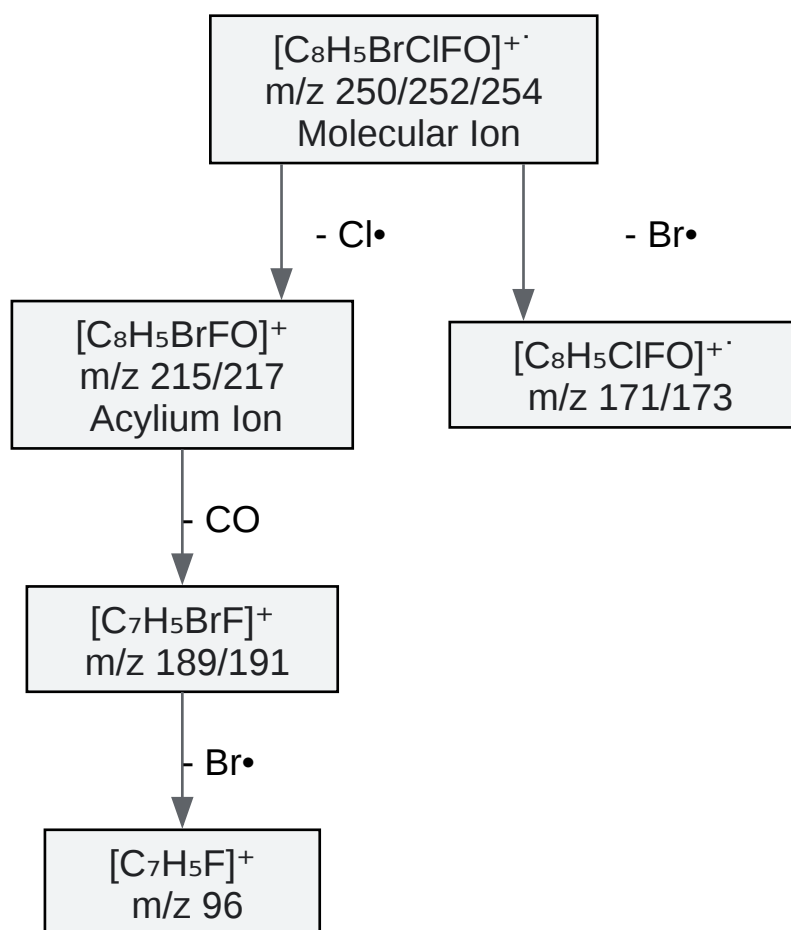

[Click to download full resolution via product page](#)

### Need Custom Synthesis?

BenchChem offers custom synthesis for rare earth carbides and specific isotopic labeling.

Email: [info@benchchem.com](mailto:info@benchchem.com) or [Request Quote Online](#).

## Sources

- [1. 3-Bromobenzoyl chloride \(CAS 1711-09-7\) - Chemical & Physical Properties by Cheméo \[cheméo.com\]](#)
- [2. pdf.benchchem.com \[pdf.benchchem.com\]](#)
- [3. Electron ionization and electrospray ionization mass spectrometric study of a series of isomeric N-chloro\(or bromo\)benzyl-substituted \(E\)-2'\(3'- or 4'\)-hydroxy-4-stilbazole halides - PubMed \[pubmed.ncbi.nlm.nih.gov\]](#)
- [4. Benzoyl chloride, 4-bromo- \[webbook.nist.gov\]](#)
- [5. Benzoyl chloride, 3-bromo- | C7H4BrClO | CID 74377 - PubChem \[pubchem.ncbi.nlm.nih.gov\]](#)
- [6. PubChemLite - 3-bromobenzoyl chloride \(C7H4BrClO\) \[pubchemlite.lcsb.uni.lu\]](#)
- [To cite this document: BenchChem. \[A Comparative Guide to the Mass Spectrometry Fragmentation of Halogenated Benzoyl Chlorides\]. BenchChem, \[2026\]. \[Online PDF\]. Available at: \[https://www.benchchem.com/product/b2445418/docs#a-comparative-guide-to-the-mass-spectrometry-fragmentation-of-halogenated-benzoyl-chlorides\]](#)

---

#### Disclaimer & Data Validity:

The information provided in this document is for Research Use Only (RUO) and is strictly not intended for diagnostic or therapeutic procedures. While BenchChem strives to provide accurate protocols, we make no warranties, express or implied, regarding the fitness of this product for every specific experimental setup.

**Technical Support:** The protocols provided are for reference purposes. Unsure if this reagent suits your experiment?

**Need Industrial/Bulk Grade?** [Request Custom Synthesis Quote](#)

## BenchChem

Our mission is to be the trusted global source of essential and advanced chemicals, empowering scientists and researchers to drive progress in science and industry.

#### Contact

Address: 3281 E Guasti Rd

Ontario, CA 91761, United States

Phone: (601) 213-4426

Email: [info@benchchem.com](mailto:info@benchchem.com)

Contact our Ph.D. Support Team for a compatibility check