

# Application Notes and Protocols for the Ethylation of 4-Aminophenol

**Author:** BenchChem Technical Support Team. **Date:** May 2026

## Compound of Interest

**Compound Name:** 4-(Ethylamino)phenol  
hydrochloride

**CAS No.:** 746637-08-1

**Cat. No.:** B2442490

[Get Quote](#)

For Researchers, Scientists, and Drug Development Professionals

## Introduction: The Strategic Importance of 4-Ethoxyaniline

4-Ethoxyaniline, the product of the ethylation of 4-aminophenol, is a pivotal intermediate in the synthesis of various pharmaceuticals and dyes.[1][2] Historically, it was a key precursor in the production of the analgesic and antipyretic drug phenacetin.[3][4] While the use of phenacetin has been largely discontinued due to concerns about its side effects, the methodologies for the selective ethylation of 4-aminophenol remain highly relevant in modern organic synthesis.[5] Understanding and controlling the reaction conditions for this transformation is crucial for achieving high yields and purity, which is of paramount importance in the drug development pipeline.

This guide provides a detailed exploration of the reaction conditions for the ethylation of 4-aminophenol, focusing on the underlying chemical principles, practical experimental protocols, and strategies to overcome common challenges.

## Core Reaction Chemistry: The Williamson Ether Synthesis

The ethylation of 4-aminophenol is a classic example of the Williamson ether synthesis. This reaction proceeds via a bimolecular nucleophilic substitution (SN2) mechanism.<sup>[6]</sup> The core principle involves the deprotonation of the phenolic hydroxyl group of 4-aminophenol by a base to form a more nucleophilic phenoxide ion. This phenoxide then attacks an ethylating agent, such as ethyl iodide or ethyl bromide, displacing the halide leaving group to form the desired ether linkage.<sup>[7]</sup>

### The Challenge of Selectivity: O- vs. N-Alkylation

A significant challenge in the ethylation of 4-aminophenol is the presence of two nucleophilic sites: the hydroxyl group (O-alkylation) and the amino group (N-alkylation).<sup>[8]</sup> Direct alkylation can lead to a mixture of O-ethylated, N-ethylated, and N,O-diethylated products, complicating purification and reducing the yield of the desired 4-ethoxyaniline.<sup>[8]</sup>

Strategies to achieve selective O-alkylation are therefore critical. One effective approach is to protect the amino group prior to the ethylation step. This can be achieved by reacting 4-aminophenol with an aldehyde, such as benzaldehyde, to form a Schiff base (imine).<sup>[9]</sup> The imine protects the amino group from alkylation, directing the subsequent reaction with the ethylating agent to the hydroxyl group. The protecting group can then be removed by hydrolysis to yield the desired O-alkylated product.<sup>[9]</sup>

An alternative and widely practiced strategy, particularly in the synthesis of phenacetin, is to start with N-acetyl-4-aminophenol (acetaminophen).<sup>[10]</sup> The acetyl group effectively protects the nitrogen atom, thus ensuring that the Williamson ether synthesis occurs exclusively at the phenolic oxygen.

### Visualizing the Reaction Pathway

The following diagram illustrates the Williamson ether synthesis for the ethylation of 4-aminophenol, highlighting the key steps of deprotonation and nucleophilic attack.

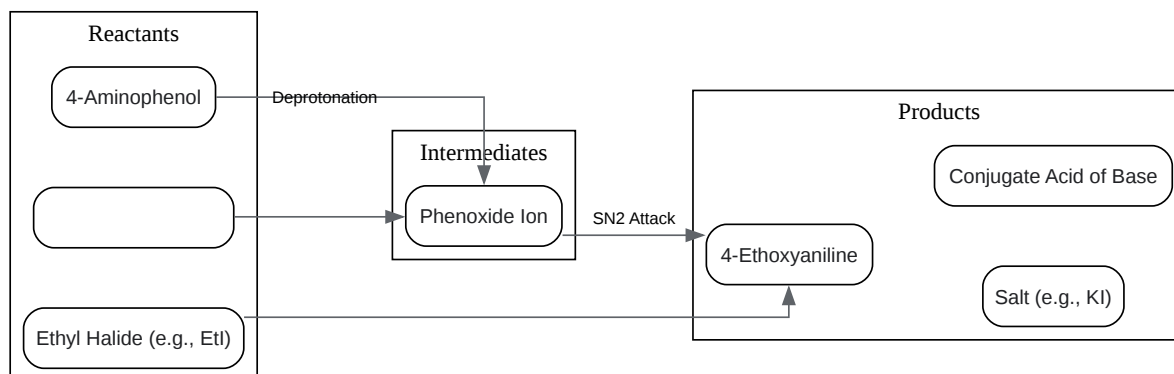

[Click to download full resolution via product page](#)

Caption: Williamson Ether Synthesis of 4-Ethoxyaniline.

## Experimental Protocols

The following protocols provide detailed, step-by-step methodologies for the ethylation of 4-aminophenol. Protocol 1 describes the direct ethylation with a focus on conditions that favor O-alkylation, while Protocol 2 outlines the synthesis via the more selective route using acetaminophen.

### Protocol 1: Direct Ethylation of 4-Aminophenol (with N-protection)

This protocol involves the protection of the amino group as a Schiff base, followed by ethylation and deprotection.

#### Step 1: Protection of the Amino Group

- In a round-bottom flask, dissolve 4-aminophenol (1 equivalent) in methanol.
- Add benzaldehyde (1 equivalent) to the solution and stir at room temperature for 1 hour.<sup>[9]</sup>

- Remove the solvent under reduced pressure to obtain the crude N-benzylidene-4-aminophenol. This can be purified by recrystallization from ethanol if necessary.[9]

#### Step 2: Ethylation of the Protected Aminophenol

- To a solution of N-benzylidene-4-aminophenol (1 equivalent) in acetone, add anhydrous potassium carbonate (2 equivalents) and ethyl iodide (1 equivalent).[9]
- Reflux the mixture for approximately 20 hours, monitoring the reaction progress by Thin Layer Chromatography (TLC).[9]
- After the reaction is complete, cool the mixture to room temperature and filter to remove the inorganic salts.
- Evaporate the solvent from the filtrate to obtain the crude O-ethylated Schiff base.

#### Step 3: Deprotection

- Dissolve the crude product from Step 2 in a suitable solvent and treat with aqueous hydrochloric acid to hydrolyze the imine.
- Stir the mixture until the deprotection is complete (monitored by TLC).
- Neutralize the solution with a base (e.g., sodium bicarbonate) and extract the product with an organic solvent (e.g., ethyl acetate).
- Wash the organic layer with brine, dry over anhydrous sodium sulfate, and concentrate under reduced pressure to yield crude 4-ethoxyaniline.
- Purify the product by column chromatography or recrystallization.

## Protocol 2: Ethylation of N-Acetyl-4-Aminophenol (Acetaminophen)

This is a common and highly selective method for the synthesis of the N-acetylated derivative of 4-ethoxyaniline (phenacetin).

#### Step 1: Reaction Setup

- In a dry round-bottom flask, combine N-acetyl-4-aminophenol (acetaminophen) (1 equivalent), anhydrous potassium carbonate (1.5-2 equivalents), and a suitable solvent such as 2-butanone.[10]
- Add ethyl iodide (1.5 equivalents) to the mixture.[10]
- Equip the flask with a reflux condenser and a magnetic stir bar.

#### Step 2: Reaction Execution

- Heat the reaction mixture to reflux and maintain for 1-2 hours.[11] The progress of the reaction can be monitored by TLC.
- After the reaction is complete, allow the mixture to cool to room temperature.

#### Step 3: Workup and Purification

- Add water to the reaction mixture to dissolve the inorganic salts.[10]
- Transfer the mixture to a separatory funnel and extract the product with an organic solvent such as tert-butyl methyl ether.[10]
- Wash the organic layer sequentially with 5% aqueous sodium hydroxide (to remove any unreacted acetaminophen), water, and brine.
- Dry the organic layer over anhydrous sodium sulfate.
- Filter to remove the drying agent and evaporate the solvent to obtain the crude product.
- Purify the product by recrystallization, for example, from an ethanol-water mixture.[12]

## Comparison of Reaction Conditions

The following table summarizes various reaction conditions for the ethylation of N-acetyl-4-aminophenol, a close analog of 4-aminophenol, to provide a comparative overview.

Starting Material	Ethylating Agent	Base	Solvent	Temperature (°C)	Time (h)	Yield (%)	Reference
N-acetyl-4-aminophenol	Ethyl iodide	Sodium ethoxide	Ethanol	Reflux	1	80	[3]
N-acetyl-4-aminophenol	Ethyl bromide	50% aq. NaOH	Methanol	Reflux	2	Not specified	[11]
N-acetyl-4-aminophenol	Bromoethane	25% Sodium methoxide	Ethanol	Reflux	0.75	Not specified	[12]
N-acetyl-4-aminophenol	Ethyl iodide	Potassium carbonate	2-Butanone	Reflux	1	Not specified	[10]

## Troubleshooting Guide

Issue	Potential Cause(s)	Suggested Solution(s)
Low or no product yield	- Incomplete deprotonation of the hydroxyl group.- Inactive ethylating agent.- Insufficient reaction time or temperature.	- Use a stronger base or ensure the base is anhydrous.- Use fresh or purified ethylating agent.- Increase reaction time and/or temperature, monitoring by TLC.
Presence of N-alkylated byproducts	- Direct alkylation of the unprotected amino group.	- Protect the amino group prior to ethylation (see Protocol 1).- Use N-acetyl-4-aminophenol as the starting material (see Protocol 2).
Formation of ethene (elimination byproduct)	- Use of a sterically hindered or strong base, favoring E2 elimination with the ethylating agent.	- Use a milder base such as potassium carbonate.- Maintain a moderate reaction temperature.
Difficulty in product isolation/purification	- Emulsion formation during workup.- Product co-crystallizing with impurities.	- Add brine to the aqueous layer to break emulsions.- Optimize the recrystallization solvent system. Consider column chromatography for purification.

## Industrial Considerations: Phase-Transfer Catalysis

For industrial-scale synthesis, phase-transfer catalysis (PTC) is often employed to facilitate the reaction between the water-soluble phenoxide and the organic-soluble ethylating agent.<sup>[6]</sup> A phase-transfer catalyst, typically a quaternary ammonium salt, transports the phenoxide anion from the aqueous phase to the organic phase where the reaction occurs.<sup>[13]</sup> This method can improve reaction rates, allow for milder reaction conditions, and simplify the workup process.<sup>[14]</sup>

## Conclusion

The ethylation of 4-aminophenol is a well-established reaction with significant applications in chemical synthesis. By understanding the principles of the Williamson ether synthesis and implementing strategies to control selectivity, researchers can effectively produce 4-ethoxyaniline and its derivatives. The choice of protecting groups, bases, solvents, and reaction conditions all play a crucial role in achieving high yields and purity. The protocols and troubleshooting guide provided herein serve as a comprehensive resource for scientists and professionals engaged in this area of research and development.

## References

- Comprehensive Organic Chemistry Experiments for the Laboratory Classroom. (2020). Books Gateway. [\[Link\]](#)
- Phenacetin Synthesis: Lab Report on 4-Aminophenol Transformation. Studylib. [\[Link\]](#)
- Preparation of phenacetin. (2022, March 9). YouTube. [\[Link\]](#)
- Two Methods for the Synthesis of Phenacetin. Chemical Education Resources. [\[Link\]](#)
- CHM2210 Chapter 11 Problem Solving Williamson Ether Synthesis 041620. (2020, April 16). YouTube. [\[Link\]](#)
- Williamson Ether Synthesis. Utah Tech University. [\[Link\]](#)
- The Williamson Ether Synthesis. (2014, October 24). Master Organic Chemistry. [\[Link\]](#)
- Williamson Ether Synthesis. University of Wisconsin-River Falls. [\[Link\]](#)
- Williamson Ether Synthesis. Organic Chemistry Tutor. [\[Link\]](#)
- 1. The Williamson Ether Synthesis. University of Wisconsin-La Crosse. [\[Link\]](#)
- Williamson Ether Synthesis reaction. BYJU'S. [\[Link\]](#)
- Organic Chemistry Williamson Ether Synthesis. University of Richmond. [\[Link\]](#)
- Phase Transfer Catalysis. Dalal Institute. [\[Link\]](#)

- Mechanism of Phase-Transfer Catalysis & Relevance to PTC Process Development. PTC Organics. [\[Link\]](#)
- The Essential Role of 4-Ethoxyaniline in Modern Chemical Synthesis. Globe Newswire. [\[Link\]](#)
- PHASE TRANSFER CATALYSIS: A GREEN METHODOLOGY FOR NEW DRUG DISCOVERY RESEARCH: A REVIEW. (2018, May 31). World Journal of Pharmacy and Pharmaceutical Sciences. [\[Link\]](#)
- phase transfer catalyst. Little Flower College Guruvayoor. [\[Link\]](#)
- Selective alkylation of the amino group of aminophenols | Download Table. ResearchGate. [\[Link\]](#)
- Dulcin. Organic Syntheses Procedure. [\[Link\]](#)
- What is the best way to purify a crude reaction mixture that auto-crystallizes?. (2023, February 6). Biotage. [\[Link\]](#)
- The identification of byproducts from the catalytic reduction reaction of 4-nitrophenol to 4-aminophenol: A systematic spectroscopic study. (2022, August 15). PubMed. [\[Link\]](#)
- (PDF) Selective alkylation of aminophenols. ResearchGate. [\[Link\]](#)
- Williamson Ether Synthesis: please bare with a lengthy question. (2018, August 14). Reddit. [\[Link\]](#)
- N-alkylation of aminophenols. (2025, January 28). Reddit. [\[Link\]](#)
- CN110740987A - Process for the mono-N-alkylation of aminophenols.
- Flow Alkylation of Thiols, Phenols, and Amines Using a Heterogenous Base in a Packed-Bed Reactor. ResearchGate. [\[Link\]](#)
- Efficient one-pot hydrogenation and acetylation of 4-nitrophenol for selective synthesis of 4-aminophenol and paracetamol with a reusable Ni catalyst. Reaction Chemistry & Engineering (RSC Publishing). [\[Link\]](#)

- Aminophenol: Properties, Production, Reactions And Uses. (2025, September 10). Chemcess. [[Link](#)]
- Preparation of N-acetyl-para-aminophenol via a flow route of a clean amination and acylation of p-nitrophenol catalyzing by core-shell Cu<sub>2</sub>O@CeO<sub>2</sub>. Arabian Journal of Chemistry. [[Link](#)]
- 4-ethylpyridine. Organic Syntheses Procedure. [[Link](#)]
- Synthesis of Mixed Carbonates via a Three-Component Coupling of Alcohols, CO<sub>2</sub>, and Alkyl Halides in the Presence of K<sub>2</sub>CO<sub>3</sub> and Tetrabutylammonium Iodide. PMC. [[Link](#)]

### Need Custom Synthesis?

BenchChem offers custom synthesis for rare earth carbides and specific isotopic labeling.

Email: [info@benchchem.com](mailto:info@benchchem.com) or [Request Quote Online](#).

## Sources

1. [macmillan.princeton.edu](http://macmillan.princeton.edu) [[macmillan.princeton.edu](http://macmillan.princeton.edu)]
2. CAS 156-43-4: 4-Ethoxyaniline | CymitQuimica [[cymitquimica.com](http://cymitquimica.com)]
3. [alfa-chemical.com](http://alfa-chemical.com) [[alfa-chemical.com](http://alfa-chemical.com)]
4. [m.youtube.com](https://m.youtube.com) [[m.youtube.com](https://m.youtube.com)]
5. [books.rsc.org](http://books.rsc.org) [[books.rsc.org](http://books.rsc.org)]
6. [byjus.com](http://byjus.com) [[byjus.com](http://byjus.com)]
7. [masterorganicchemistry.com](http://masterorganicchemistry.com) [[masterorganicchemistry.com](http://masterorganicchemistry.com)]
8. [chemcess.com](http://chemcess.com) [[chemcess.com](http://chemcess.com)]
9. [researchgate.net](http://researchgate.net) [[researchgate.net](http://researchgate.net)]
10. [gold-chemistry.org](http://gold-chemistry.org) [[gold-chemistry.org](http://gold-chemistry.org)]
11. [studylib.net](http://studylib.net) [[studylib.net](http://studylib.net)]
12. [glaserr.missouri.edu](http://glaserr.missouri.edu) [[glaserr.missouri.edu](http://glaserr.missouri.edu)]
13. [littleflowercollege.edu.in](http://littleflowercollege.edu.in) [[littleflowercollege.edu.in](http://littleflowercollege.edu.in)]

- [14. dalalinstitute.com \[dalalinstitute.com\]](https://dalalinstitute.com)
- To cite this document: BenchChem. [Application Notes and Protocols for the Ethylation of 4-Aminophenol]. BenchChem, [2026]. [Online PDF]. Available at: [<https://www.benchchem.com/product/b2442490/docs#application-notes-and-protocols-for-the-ethylation-of-4-aminophenol>]

---

### Disclaimer & Data Validity:

The information provided in this document is for Research Use Only (RUO) and is strictly not intended for diagnostic or therapeutic procedures. While BenchChem strives to provide accurate protocols, we make no warranties, express or implied, regarding the fitness of this product for every specific experimental setup.

**Technical Support:** The protocols provided are for reference purposes. Unsure if this reagent suits your experiment?

**Need Industrial/Bulk Grade?** [Request Custom Synthesis Quote](#)

## BenchChem

Our mission is to be the trusted global source of essential and advanced chemicals, empowering scientists and researchers to drive progress in science and industry.

### Contact

Address: 3281 E Guasti Rd  
Ontario, CA 91761, United States  
Phone: (601) 213-4426  
Email: [info@benchchem.com](mailto:info@benchchem.com)

[Contact our Ph.D. Support Team for a compatibility check](#)