

Technical Guide: Solubility & Handling of Methyl 4-(chloromethoxy)benzoate

Author: BenchChem Technical Support Team. **Date:** May 2026

Compound of Interest

Compound Name: Methyl 4-(chloromethoxy)benzoate

CAS No.: 135922-45-1

Cat. No.: B2438256

[Get Quote](#)

Part 1: Executive Summary & Compound Identity

Methyl 4-(chloromethoxy)benzoate is a specialized electrophilic intermediate used primarily in medicinal chemistry for installing the 4-(methoxycarbonyl)phenyloxymethyl moiety or as a precursor for protecting groups. Unlike its stable analog Methyl 4-(chloromethyl)benzoate (CAS 34040-64-7), this compound contains a chloromethyl aryl ether motif (

), rendering it highly susceptible to hydrolysis and solvolysis.

Structural Disambiguation

Researchers often confuse this compound with structurally similar analogs. Correct identification is critical for solvent selection.[\[1\]](#)

Compound Name	Structure Fragment	Reactivity Class	CAS (Representative)
Methyl 4-(chloromethoxy)benzoate		High (Alpha-halo ether)	Niche Intermediate
Methyl 4-(chloromethyl)benzoate		Moderate (Benzyl chloride)	34040-64-7
Methyl 4-[(chloromethoxy)methyl]benzoate		High (MOM-Cl derivative)	88045-74-3

Note: This guide focuses on the Aryl-O-CH₂-Cl species. Due to its high reactivity, "solubility" must be interpreted as "solvent compatibility."

Part 2: Physicochemical Profile & Solubility Analysis

Predicted Properties[2]

- Molecular Formula:
- Molecular Weight: 200.62 g/mol
- LogP (Estimated): 2.1 – 2.5 (Lipophilic)
- Physical State: Likely a low-melting solid or viscous oil (due to disruption of crystal packing by the ether linkage).

Solvent Compatibility Matrix

The solubility of **Methyl 4-(chloromethoxy)benzoate** is governed by its lipophilicity, but its utility is dictated by chemical stability.

Category A: Recommended Solvents (Inert & Soluble)

These solvents dissolve the compound (>100 mg/mL) without triggering decomposition.

- Dichloromethane (DCM): The gold standard. High solubility due to polarity matching; non-nucleophilic.
- Toluene: Excellent for heating/reflux conditions if required; azeotropically removes water.
- Tetrahydrofuran (THF): Good solubility, but must be anhydrous. Commercial THF stabilized with BHT is acceptable; avoid peroxides.
- Ethyl Acetate: Suitable for rapid extractions, though long-term storage is not recommended due to potential transesterification risks (minor).

Category B: Incompatible Solvents (Reactive)

Do NOT use these solvents. The compound will degrade rapidly.

- Methanol / Ethanol: Immediate solvolysis occurs via an
pathway, forming the corresponding acetal (
) and releasing HCl.
- Water: Rapid hydrolysis to Methyl 4-hydroxybenzoate, Formaldehyde, and HCl.
- DMSO / DMF: While soluble, these polar aprotic solvents can act as nucleophiles (e.g., Kornblum oxidation-like pathways) or accelerate hydrolysis due to hygroscopicity.

Part 3: Experimental Protocols

Solubility & Stability Testing Workflow

Use this protocol to verify solvent quality before committing valuable material.

Step 1: Preparation

- Dry 5 mL of the target solvent (DCM or Toluene) over molecular sieves (3Å or 4Å) for 12 hours.
- Ensure glassware is oven-dried (

) and purged with Nitrogen/Argon.

Step 2: Dissolution

- Add 50 mg of **Methyl 4-(chloromethoxy)benzoate** to 1 mL of solvent.
- Observation: The solution should be clear and colorless. Turbidity or fuming indicates moisture contamination (hydrolysis releasing HCl gas).

Step 3: Stability Check (NMR)

- Take an aliquot () and dilute with .
- Diagnostic Signal: Look for the singlet corresponding to around 5.6 – 5.9 ppm.
- Degradation: Disappearance of this peak and appearance of a broad singlet at 9-10 ppm (Formaldehyde) or 5.0-5.2 ppm (Hemiacetal) indicates incompatibility.

Synthesis & Solvent Handling (In Situ Generation)

Since this compound is unstable, it is often generated in situ in DCM.

- Reagents: Methyl 4-hydroxybenzoate (1.0 equiv), Paraformaldehyde (1.2 equiv).
- Solvent: Anhydrous Dichloromethane (DCM).
- Reagent: HCl gas (bubbled) or / Thionyl Chloride.

- Procedure:
 - Suspend Methyl 4-hydroxybenzoate and paraformaldehyde in DCM at .
 - Bubble dry HCl gas through the solution.[1] The paraformaldehyde depolymerizes and reacts with the phenol.
 - Solubility Transition: The suspension clears as the lipophilic chloromethyl ether forms.
 - Workup: Decant from solid residues. Do not wash with water. Remove solvent under reduced pressure strictly below .

Part 4: Mechanism & Safety Visualization

Reactivity & Degradation Pathways

The following diagram illustrates why protic solvents are forbidden.

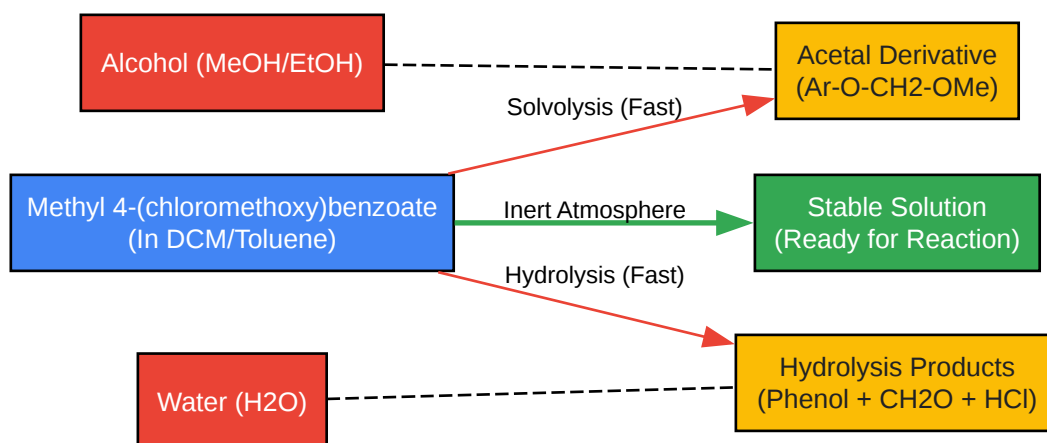

[Click to download full resolution via product page](#)

Caption: Stability logic flow. Blue indicates the target compound; Red indicates destructive solvents; Green indicates safe handling.

Safety: Carcinogenicity Warning

Critical Hazard: Chloromethyl ethers (including aryl analogs) are potential alkylating agents and carcinogens.

- Bis(chloromethyl) ether (BCME): A potent carcinogen often formed as a byproduct if water is present during synthesis.[2]
- Handling: All solubility testing must occur in a fume hood. Double-glove (Nitrile + Laminate) is recommended.

Part 5: References

- VulcanChem. (2024). Physicochemical Properties of Chloromethyl Ethers and Benzoate Derivatives. Retrieved from
- Organic Syntheses. (2025). Ortho-Formylation of Phenols via Chloromethyl Intermediates. Org. Synth. Coll. Vol. X. Retrieved from [\[Link\]](#)
- PubChem. (2025). Compound Summary: Chloromethyl ethers and reactivity profiles. National Library of Medicine. Retrieved from [\[Link\]](#)

Need Custom Synthesis?

BenchChem offers custom synthesis for rare earth carbides and specific isotopic labeling.

Email: info@benchchem.com or [Request Quote Online](#).

Sources

- 1. GT Digital Repository [repository.gatech.edu]
- 2. Blanc chloromethylation - Wikipedia [en.wikipedia.org]
- To cite this document: BenchChem. [Technical Guide: Solubility & Handling of Methyl 4-(chloromethoxy)benzoate]. BenchChem, [2026]. [Online PDF]. Available at: [<https://www.benchchem.com/product/b2438256/docs#technical-guide-solubility-handling-of-methyl-4-chloromethoxy-benzoate>]

Disclaimer & Data Validity:

The information provided in this document is for Research Use Only (RUO) and is strictly not intended for diagnostic or therapeutic procedures. While BenchChem strives to provide accurate protocols, we make no warranties, express or implied, regarding the fitness of this product for every specific experimental setup.

Technical Support: The protocols provided are for reference purposes. Unsure if this reagent suits your experiment?

Need Industrial/Bulk Grade? [Request Custom Synthesis Quote](#)

BenchChem

Our mission is to be the trusted global source of essential and advanced chemicals, empowering scientists and researchers to drive progress in science and industry.

Contact

Address: 3281 E Guasti Rd
Ontario, CA 91761, United States
Phone: (601) 213-4426
Email: info@benchchem.com

[Contact our Ph.D. Support Team for a compatibility check](#)