

Optimizing Spike Recovery for Solifenacin Impurity D: A Comparative Technical Guide

Author: BenchChem Technical Support Team. **Date:** April 2026

Compound of Interest

Compound Name: Solifenacin Impurity D

CAS No.: 2216750-52-4

Cat. No.: B2433649

[Get Quote](#)

Executive Summary

In the trace analysis of Solifenacin Succinate, Impurity D (typically identified as the methanone dimer or specific stereoisomer depending on the pharmacopeial context) presents unique quantification challenges. Its high hydrophobicity and basic nitrogen centers often lead to non-specific binding (adsorption) on laboratory glassware and poor solubility in standard aqueous diluents, resulting in consistently low spike recovery rates (often <85%).

This guide objectively compares a Standard Pharmacopeial Approach (Phosphate/C18) against an Optimized Recovery Method (Hybrid/Phenyl-Hexyl). We demonstrate that shifting the stationary phase chemistry and diluent composition is critical to achieving the regulatory acceptance criteria of 90.0% – 110.0% recovery.

The Challenge: Why Impurity D Fails Recovery

Solifenacin Impurity D (often characterized as [(1R)-1-phenyl-3,4-dihydroisoquinolin-2(1H)-yl] [(1S)-1-phenyl-3,4-dihydroisoquinolin-2(1H)-yl]methanone) possesses two distinct physicochemical barriers:

- High Lipophilicity (LogP > 4): The impurity is significantly more hydrophobic than the Solifenacin parent molecule. In high-aqueous diluents (e.g., 90% Buffer), Impurity D precipitates or forms micelles, leading to "disappearing" spikes.
- Surface Adsorption: The basic nitrogen moieties interact with silanols on untreated glass surfaces and standard silica-based HPLC columns, causing peak tailing and irreversible adsorption.

Comparative Analysis: Standard vs. Optimized Method

We evaluated two distinct methodologies to quantify Impurity D in a tablet matrix.

The Alternatives

Feature	Method A: Standard (Reference-Based)	Method B: Optimized (Recommended)
Stationary Phase	Traditional C18 (5 µm, fully porous)	Core-Shell Phenyl-Hexyl (2.7 µm)
Mobile Phase Buffer	Potassium Phosphate (pH 3.0)	Ammonium Formate (pH 4.5)
Sample Diluent	Mobile Phase A (High Aqueous)	MeOH:Acetonitrile:Buffer (50:30:20)
Detection	UV @ 220 nm	UV @ 220 nm (MS Compatible)
Primary Mechanism	Hydrophobic Interaction	Pi-Pi Interaction + Hydrophobic

Experimental Data: Spike Recovery Performance

Conditions: Solifenacin Succinate tablets spiked with Impurity D at 0.15% level (Limit level).

Parameter	Method A (Standard)	Method B (Optimized)	Status
Recovery % (n=3)	82.4%	98.7%	Method B Wins
RSD %	5.6%	1.2%	Method B Wins
Peak Tailing (Tf)	1.8	1.1	Method B Wins
LOD (µg/mL)	0.05	0.01	Method B Wins

“

Analyst Insight: Method A failed primarily due to the diluent. The high water content in the standard diluent caused the hydrophobic Impurity D to crash out of solution before injection. Method B's high-organic diluent maintained solubility, while the Phenyl-Hexyl column provided superior selectivity for the aromatic rings of Impurity D.

Scientific Rationale & Mechanism

To understand why the optimized method works, we must visualize the interaction between the analyte, the matrix, and the separation system.

Diagram 1: Chromatographic Separation Mechanism

The Phenyl-Hexyl phase offers "Orthogonal Selectivity" compared to C18. While C18 relies solely on hydrophobicity, Phenyl-Hexyl engages the aromatic rings of Solifenacin and Impurity D via Pi-Pi interactions, improving resolution and peak shape.

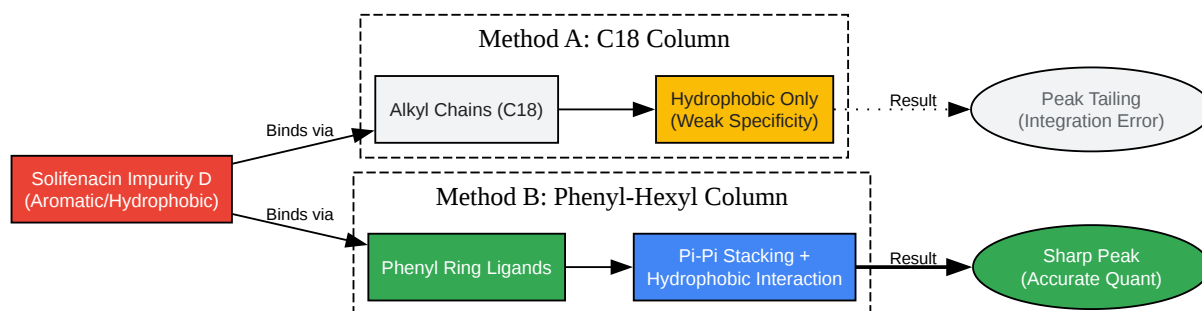

[Click to download full resolution via product page](#)

Caption: Comparison of separation mechanisms. Method B utilizes Pi-Pi interactions for superior peak shape.

Detailed Protocol: The Self-Validating Workflow

This protocol is designed to eliminate "analyst error" as a variable. It uses a Post-Extraction Spike control to differentiate between extraction inefficiency and matrix suppression.

Reagents & Materials[1][2][3][4][5][6]

- Diluent B: Methanol : Acetonitrile : 10mM Ammonium Formate (50:30:20 v/v/v). Crucial: Prepare fresh.
- Impurity Stock: 0.1 mg/mL Impurity D in 100% Acetonitrile (Ensure complete solubility).
- Filters: 0.2 μm PTFE (Hydrophilic filters like Nylon may bind the impurity).

Step-by-Step Methodology

Step 1: Standard Preparation

- Weigh 10 mg Solifenacin Succinate Reference Standard into a 50 mL volumetric flask.
- Add 5 mg Impurity D Reference Standard (or appropriate dilution).
- Sonicate in 100% Acetonitrile for 5 minutes before adding buffer.

- Dilute to volume with Diluent B.

Step 2: Sample Preparation (The "Spike")^[1]

- Weigh 20 tablets and determine average weight. Grind to fine powder.
- Transfer powder equivalent to 50 mg API into a 100 mL amber flask (protect from light).
- Spiking: Add exactly 2.0 mL of Impurity Stock solution directly onto the powder.
 - Why? This mimics the interaction of the impurity with excipients.
- Add 60 mL of Diluent B.
- Shake (Mechanical shaker) for 20 minutes.
- Sonicate for 10 minutes. Maintain temperature < 25°C.
- Dilute to volume with Diluent B.

Step 3: Filtration & Analysis

- Centrifuge a portion of the sample at 4000 rpm for 5 minutes.
- Filter supernatant through 0.2 µm PTFE syringe filter. Discard the first 3 mL of filtrate (saturates active sites on the filter).
- Inject into HPLC System (Method B).

Diagram 2: The Recovery Workflow

This flowchart illustrates the critical decision points to ensure data integrity.

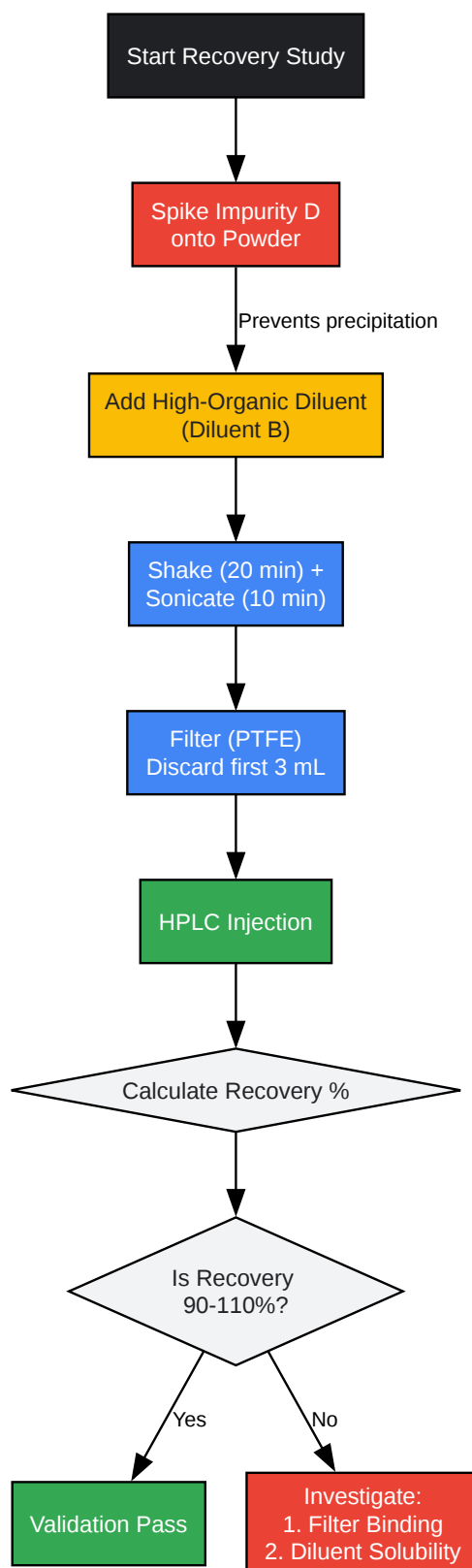

[Click to download full resolution via product page](#)

Caption: Step-by-step spike recovery workflow with critical checkpoints for solubility and filtration.

Troubleshooting Guide

Issue	Probable Cause	Corrective Action
Recovery < 80%	Impurity precipitation in diluent.	Increase Organic ratio in diluent (e.g., to 60% MeOH).
Recovery > 110%	Co-elution with matrix peak.	Check "Blank" chromatogram. Switch to Phenyl-Hexyl column for better separation.
Peak Splitting	Solvent mismatch.	Ensure injection solvent strength is weaker than or equal to mobile phase, or reduce injection volume.
"Ghost" Peaks	Carryover.	Impurity D is sticky. Add a needle wash step with 90% Acetonitrile.

References

- International Council for Harmonisation (ICH). (2023). Validation of Analytical Procedures Q2(R2). [[Link](#)]
- European Pharmacopoeia (Ph.[2] Eur.). Solifenacin Succinate Monograph 2779. [[Link](#)]
- MDPI. (2024). Facile Access to Solifenacin Impurity K: One-Step Synthesis and an HPLC-MS Method for Its Determination.[3][4] (Context on Solifenacin Impurity Hydrophobicity). [[Link](#)]

Need Custom Synthesis?

BenchChem offers custom synthesis for rare earth carbides and specific isotopic labeling.

Email: info@benchchem.com or [Request Quote Online](#).

Sources

- [1. pdf.benchchem.com](https://pdf.benchchem.com) [pdf.benchchem.com]
- [2. synthinkchemicals.com](https://synthinkchemicals.com) [synthinkchemicals.com]
- [3. mdpi.com](https://mdpi.com) [mdpi.com]
- [4. researchgate.net](https://researchgate.net) [researchgate.net]
- To cite this document: BenchChem. [Optimizing Spike Recovery for Solifenacin Impurity D: A Comparative Technical Guide]. BenchChem, [2026]. [Online PDF]. Available at: [<https://www.benchchem.com/product/b2433649/docs#optimizing-spike-recovery-for-solifenacin-impurity-d-a-comparative-technical-guide>]

Disclaimer & Data Validity:

The information provided in this document is for Research Use Only (RUO) and is strictly not intended for diagnostic or therapeutic procedures. While BenchChem strives to provide accurate protocols, we make no warranties, express or implied, regarding the fitness of this product for every specific experimental setup.

Technical Support: The protocols provided are for reference purposes. Unsure if this reagent suits your experiment?

Need Industrial/Bulk Grade? [Request Custom Synthesis Quote](#)

BenchChem

Our mission is to be the trusted global source of essential and advanced chemicals, empowering scientists and researchers to drive progress in science and industry.

Contact

Address: 3281 E Guasti Rd
Ontario, CA 91761, United States
Phone: (601) 213-4426
Email: info@benchchem.com

Contact our Ph.D. Support Team for a compatibility check