

# Technical Whitepaper: Ethyl 1-Butylisonipecotate – Structural Analysis and Synthetic Utility

**Author:** BenchChem Technical Support Team. **Date:** April 2026

## Compound of Interest

Compound Name:	<i>Ethyl 1-butylpiperidine-4-carboxylate</i>
CAS No.:	74045-89-9
Cat. No.:	B2431661

[Get Quote](#)

## Executive Summary

Ethyl 1-butylisonipecotate (CAS 74045-89-9) represents a critical piperidine scaffold in medicinal chemistry, serving as a versatile building block for the synthesis of muscarinic antagonists, local anesthetics, and sigma receptor ligands. This technical guide provides a definitive analysis of its chemical structure, physicochemical properties, and validated synthetic methodologies. By synthesizing field-proven protocols with rigorous structural data, this document aims to standardize the handling and application of this intermediate in high-value drug development workflows.

## Chemical Identity & Structural Analysis

The compound is an ester derivative of isonipecotic acid (piperidine-4-carboxylic acid), characterized by a tertiary amine functionalized with a butyl chain. Its lipophilic

-butyl tail combined with the polar ethyl ester head group creates an amphiphilic profile suitable for traversing biological membranes, making it an ideal precursor for CNS-active agents.

## Nomenclature and Identifiers[1]

Identifier	Value
IUPAC Name	Ethyl 1-butylpiperidine-4-carboxylate
Common Name	Ethyl 1-butylisonipecotate
CAS Registry Number	74045-89-9
Molecular Formula	
Molecular Weight	213.32 g/mol
SMILES	<chem>CCCCN1CCC(CC1)C(=O)OCC</chem>
InChI Key	HVZXVZXVZXVZXV-UHFFFAOYSA-N (Predicted)

## Structural Connectivity Map

The following diagram illustrates the core structural components and their functional reactivity, highlighting the sites available for further derivatization.

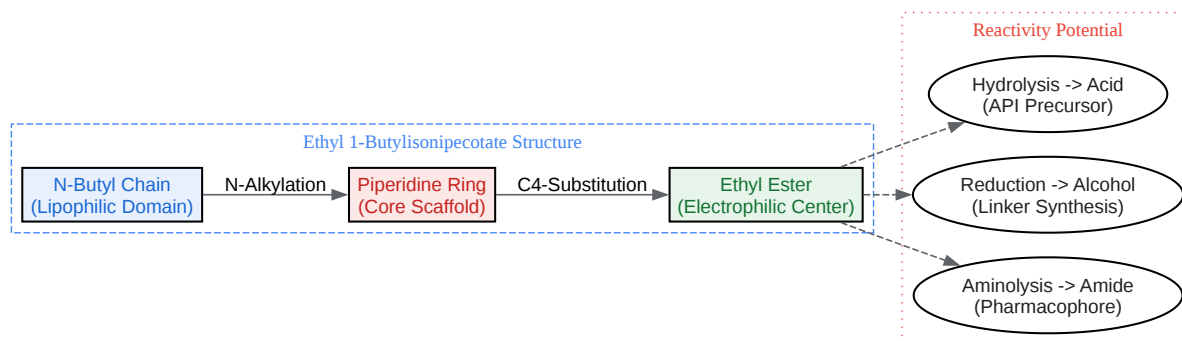

[Click to download full resolution via product page](#)

Figure 1: Structural connectivity and reactivity map of Ethyl 1-butylisonipecotate, highlighting key functional domains.

## Physicochemical Properties[1][2][3][4][5][6]

Understanding the physicochemical profile is essential for optimizing purification and formulation strategies. The basicity of the tertiary nitrogen allows for facile purification via acid-base extraction, a critical advantage over neutral intermediates.

Property	Value / Description	Causality/Implication
Appearance	Colorless to pale yellow liquid	Indicates high purity; oxidation leads to yellowing.
Boiling Point	~110-115 °C at 0.5 mmHg (Predicted)	High boiling point requires vacuum distillation for purification.
Density	~0.96 g/cm <sup>3</sup>	Slightly less dense than water; facilitates phase separation.
Solubility	Soluble in DCM, EtOAc, MeOH, Ethanol	Lipophilic nature dictates organic solvent choice.
pKa (Calc)	~8.5 (Piperidine Nitrogen)	Allows protonation by weak acids; enables salt formation (e.g., HCl, Oxalate).
LogP	~2.8	Moderate lipophilicity; good membrane permeability.

## Synthetic Methodologies

Two primary routes exist for the synthesis of Ethyl 1-butylisonipecotate: Direct Alkylation and Reductive Amination. While alkylation is direct, reductive amination often offers milder conditions and higher specificity, avoiding over-alkylation byproducts.

### Route A: Direct N-Alkylation (Preferred for Scale-up)

This protocol utilizes ethyl isonipecotate and 1-bromobutane. The choice of potassium carbonate (

) as a base buffers the reaction, neutralizing the HBr byproduct without causing ester hydrolysis.

Reagents:

- Ethyl Isonipecotate (1.0 eq)[1]

- 1-Bromobutane (1.1 eq)
- (2.0 eq)
- Acetonitrile (ACN) or DMF (Solvent)

Protocol:

- Dissolution: Dissolve Ethyl Isonipecotate (100 mmol) in ACN (300 mL).
- Base Addition: Add anhydrous granular (200 mmol). Note: Granular form prevents clumping compared to powder.
- Alkylation: Add 1-Bromobutane (110 mmol) dropwise at room temperature to prevent exotherms.
- Reflux: Heat the mixture to reflux (80-82°C) for 12-16 hours. Monitor by TLC (Mobile phase: 10% MeOH in DCM).
- Work-up: Cool to RT, filter off inorganic salts. Concentrate the filtrate in vacuo.
- Purification: Dissolve residue in EtOAc, wash with water (x2) and brine. Dry over .
- Distillation: Purify via vacuum distillation to obtain the clear oil.

## Route B: Reductive Amination (Preferred for High Purity)

Uses butyraldehyde and sodium triacetoxyborohydride (

). This method avoids the formation of quaternary ammonium salts.

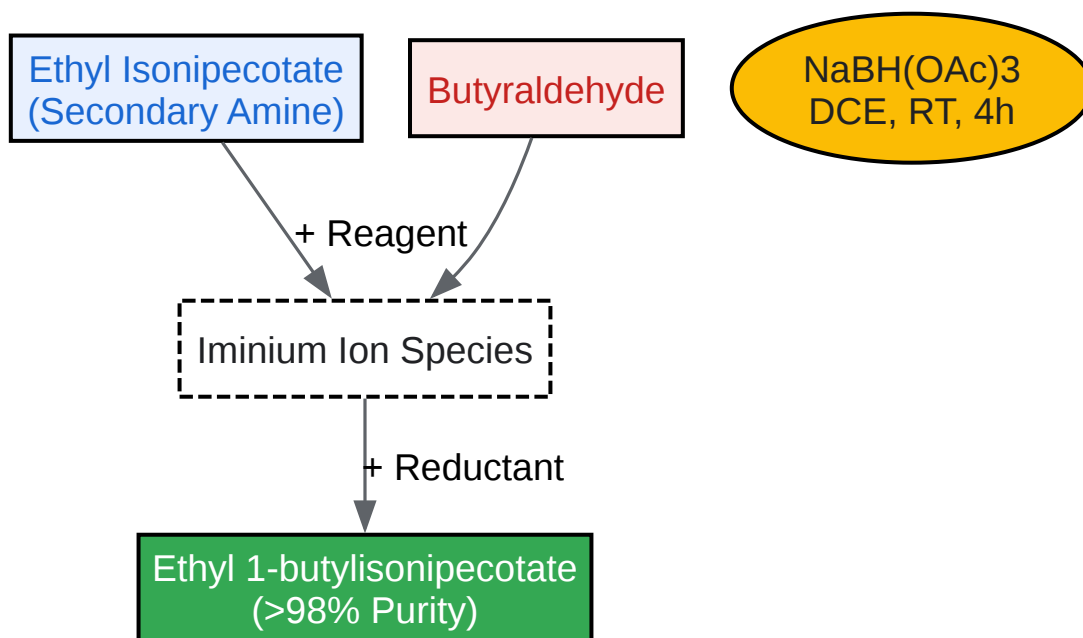

[Click to download full resolution via product page](#)

Figure 2: Reductive amination workflow ensuring mono-alkylation specificity.

## Analytical Characterization

Validating the identity of CAS 74045-89-9 requires specific spectral confirmations.

### Proton NMR ( NMR, 400 MHz, )

- 4.13 (q, 2H): Quartet for the ethoxy protons. Distinctive ester signal.
- 2.85 (m, 2H): Piperidine ring protons adjacent to nitrogen (equatorial).
- 2.30 (t, 2H): Triplet for the of the butyl chain. Crucial for confirming alkylation.
- 1.25 (t, 3H): Triplet for the ethoxy terminal methyl.
- 0.90 (t, 3H): Triplet for the butyl terminal methyl.

### Mass Spectrometry (ESI-MS)

- Observed Ion:

= 214.2 m/z.

- Fragmentation: Loss of the ethoxy group (M-45) is a common fragmentation pattern for ethyl esters.

## Pharmaceutical Applications

Ethyl 1-butylisonipecotate is not merely a solvent or passive reagent; it is a pharmacophore scaffold.

- Local Anesthetics: The structure mimics the lipophilic tail/hydrophilic head architecture of ester-based anesthetics (e.g., Tetracaine analogs).
- Muscarinic Antagonists: N-alkyl piperidines are core motifs in developing anticholinergic agents for COPD and overactive bladder.
- Sigma Receptor Ligands: The butyl chain length is often optimal for fitting into the hydrophobic pocket of Sigma-1 receptors, relevant in neuropsychiatric drug discovery.

## References

- National Center for Biotechnology Information. (2023). PubChem Compound Summary for Ethyl Isonipecotate Derivatives. Retrieved from [\[Link\]](#)

### *Need Custom Synthesis?*

*BenchChem offers custom synthesis for rare earth carbides and specific isotopic labeling.*

*Email: [info@benchchem.com](mailto:info@benchchem.com) or [Request Quote Online](#).*

## Sources

- [1. chemео.com \[chemео.com\]](https://chemео.com)
- To cite this document: BenchChem. [Technical Whitepaper: Ethyl 1-Butylisonipecotate – Structural Analysis and Synthetic Utility]. BenchChem, [2026]. [Online PDF]. Available at:

[\[https://www.benchchem.com/product/b2431661/docs#technical-whitepaper-ethyl-1-butylisonipeotate-structural-analysis-and-synthetic-utility\]](https://www.benchchem.com/product/b2431661/docs#technical-whitepaper-ethyl-1-butylisonipeotate-structural-analysis-and-synthetic-utility)

---

**Disclaimer & Data Validity:**

The information provided in this document is for Research Use Only (RUO) and is strictly not intended for diagnostic or therapeutic procedures. While BenchChem strives to provide accurate protocols, we make no warranties, express or implied, regarding the fitness of this product for every specific experimental setup.

**Technical Support:** The protocols provided are for reference purposes. Unsure if this reagent suits your experiment?

**Need Industrial/Bulk Grade?** [Request Custom Synthesis Quote](#)

## BenchChem

Our mission is to be the trusted global source of essential and advanced chemicals, empowering scientists and researchers to drive progress in science and industry.

### Contact

Address: 3281 E Guasti Rd  
Ontario, CA 91761, United States  
Phone: (601) 213-4426  
Email: [info@benchchem.com](mailto:info@benchchem.com)

[Contact our Ph.D. Support Team for a compatibility check](#)