

Technical Support Center: Preventing Decomposition of Hydrazine Reagents in Pyrazole Synthesis

Author: BenchChem Technical Support Team. **Date:** May 2026

Compound of Interest

Compound Name:	2-(4-Iodo-2-methylpyrazol-3-yl)acetic acid
CAS No.:	2490402-57-6
Cat. No.:	B2430873

[Get Quote](#)

Welcome to the technical support center for researchers, scientists, and drug development professionals. This guide is designed to address and resolve common issues related to the stability and decomposition of hydrazine reagents during pyrazole synthesis. Pyrazole synthesis, most classically the Knorr synthesis, is a cornerstone reaction, but its success is often contingent on the integrity of the hydrazine reagent, which is notoriously prone to degradation.^{[1][2][3][4]} This document provides in-depth troubleshooting advice, frequently asked questions, and validated protocols to ensure the efficiency, reproducibility, and safety of your experiments.

Troubleshooting Guide: Common Experimental Issues

This section addresses specific problems you may encounter during pyrazole synthesis, with a focus on tracing the root cause to hydrazine reagent stability and providing actionable solutions.

Issue 1: Low or Non-existent Product Yield

Question: My pyrazole synthesis is resulting in a very low yield, or I'm only recovering starting material. Could hydrazine decomposition be the culprit?

Answer: Yes, this is a very common problem directly linked to the quality and handling of the hydrazine reagent. Several factors could be at play:

- **Reagent Decomposition:** Hydrazine and its derivatives, especially liquids like hydrazine hydrate and phenylhydrazine, are susceptible to decomposition by air (oxidation), heat, and light.^{[5][6][7]} If the reagent has been stored for a long time or improperly, its effective concentration will be significantly lower than stated, leading to an incomplete reaction. Phenylhydrazine is particularly known to decompose and form colored impurities that are visible indicators of degradation.^[5]
- **Suboptimal pH Conditions:** The reaction pH is a delicate balance. While the overall condensation is often catalyzed by acid, an excessively low pH will protonate the hydrazine, rendering it non-nucleophilic and halting the reaction.^{[5][8]} This effectively removes your reagent from the productive reaction cycle.
- **Reduced Nucleophilicity:** If you are using a substituted hydrazine with electron-withdrawing groups, its nucleophilicity is inherently lower.^[5] This can lead to a sluggish or incomplete reaction, which may be mistaken for a reagent decomposition issue.
- **Excessive Heat:** While some reactions require heat, elevated temperatures can accelerate the decomposition of less stable hydrazine derivatives, reducing the amount of active reagent available for the cyclization.^[5]

Troubleshooting Workflow for Low Yield

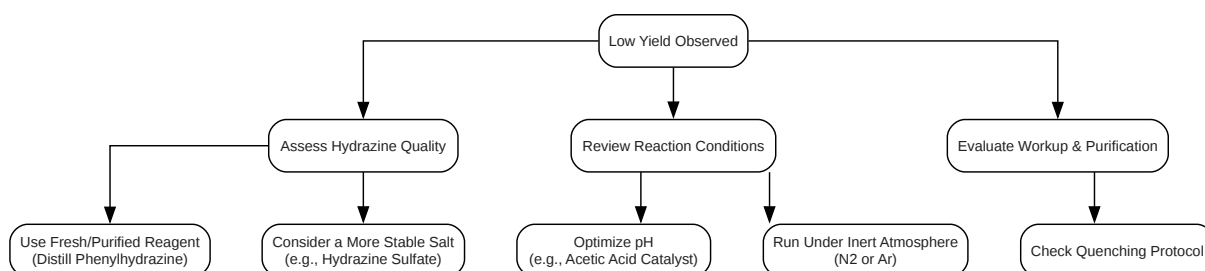

[Click to download full resolution via product page](#)

Caption: A logical workflow for troubleshooting low pyrazole yield.

Issue 2: Reaction Mixture Turns Deep Yellow, Red, or Brown

Question: My reaction mixture turned a dark color immediately after I added the phenylhydrazine. What is causing this, and will it affect my reaction?

Answer: This is a definitive visual indicator of reagent decomposition. Phenylhydrazine, in particular, is highly sensitive to air and light, and its oxidation products are intensely colored reddish-brown compounds.^[5] This color change confirms that a significant portion of your reagent has decomposed, which will invariably lower your yield and introduce impurities that can complicate purification.

Preventative Measures:

- **Use High-Purity Reagents:** Always use the highest purity hydrazine available. If you suspect your phenylhydrazine has degraded (i.e., it is already dark in the bottle), it should be purified by distillation before use.^[5]
- **Inert Atmosphere:** Purge your reaction vessel thoroughly with an inert gas like nitrogen or argon before adding solvents and reagents. Maintain a positive pressure of inert gas throughout the reaction.^{[5][9]}

- **Protect from Light:** If your reaction is light-sensitive, wrap the flask in aluminum foil. Store the reagent itself in a dark, cool place.[10][11]

Issue 3: Formation of Two Pyrazole Regioisomers

Question: I am reacting an unsymmetrical 1,3-dicarbonyl compound and getting a mixture of two pyrazole products. How can I improve the regioselectivity?

Answer: This is a classic challenge in pyrazole synthesis and is not directly a result of decomposition, but rather of the reaction mechanism itself.[1] The two carbonyl groups of your dicarbonyl substrate have different electronic and steric environments, and the initial nucleophilic attack by hydrazine can occur at either site, leading to two different intermediates and, ultimately, two regioisomeric products.[2][5]

Strategies to Influence Regioselectivity:

- **Control Reaction Conditions:** The pH, solvent, and temperature can significantly influence the ratio of isomers. Acid catalysis, for instance, can alter which carbonyl is more activated towards nucleophilic attack.[2] Experimenting with different solvents (e.g., ethanol vs. acetic acid) is a common strategy.
- **Steric Hindrance:** Bulky substituents on either the hydrazine or the dicarbonyl can direct the initial attack to the less sterically hindered carbonyl group.[5]
- **Stepwise Synthesis:** In some cases, it may be possible to protect one carbonyl group, force the reaction at the unprotected site, and then deprotect and cyclize to form a single isomer.

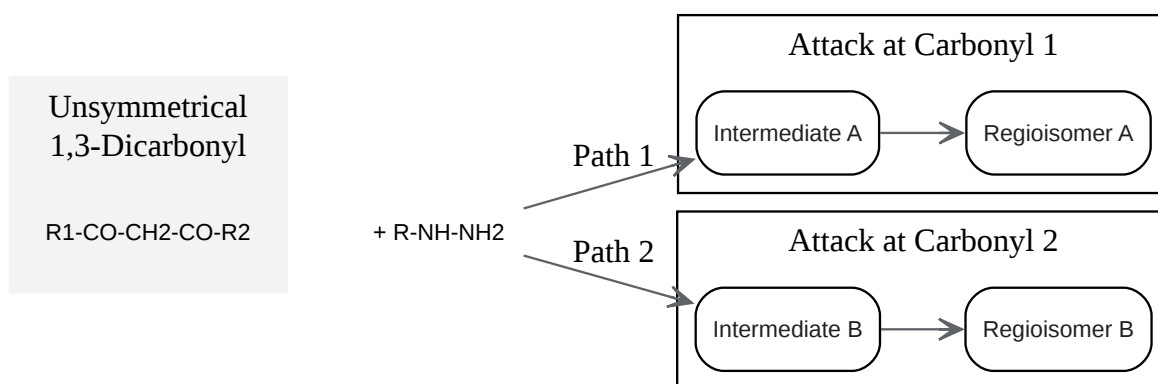

[Click to download full resolution via product page](#)

Caption: Formation of regioisomers from an unsymmetrical dicarbonyl.

Frequently Asked Questions (FAQs)

Q1: Which form of hydrazine is more stable: hydrazine hydrate or hydrazine sulfate?

A1: Hydrazine sulfate is generally considered more stable and safer to handle than hydrazine hydrate.^[5] Hydrazine hydrate is a volatile liquid, whereas hydrazine sulfate is a crystalline solid. The salt form is less prone to decomposition during storage and is often the preferred reagent when stability and handling safety are primary concerns.^[5]

Reagent	Form	Stability	Key Handling Considerations
Hydrazine Hydrate	Colorless Liquid	Less stable, volatile	Highly toxic and corrosive. ^[5] Requires careful handling in a fume hood. ^{[6][10]}
Hydrazine Sulfate	Crystalline Solid	More stable, non-volatile	Less prone to decomposition. ^[5] Easier and safer to weigh and handle.
Phenylhydrazine	Oily Liquid	Prone to oxidation	Turns reddish-brown on exposure to air/light. ^[5] Should be distilled if impure.

Q2: How can I quantitatively check the purity of my hydrazine solution before use?

A2: A simple visual inspection for color is the first step, especially for phenylhydrazine.^[5] For a quantitative assessment, two common laboratory methods are:

- **Titration:** A classic method involves titrating the hydrazine solution with a standardized oxidant, such as potassium iodate (KIO_3), in the presence of acid.[12] This is a reliable way to determine the molar concentration.
- **Spectrophotometry:** Hydrazine reacts with p-dimethylaminobenzaldehyde in an acidic solution to form a yellow azine complex with a maximum absorbance around 455 nm.[13][14] By creating a calibration curve with standards of known concentration, you can accurately determine the concentration of your sample. This is also a useful method for monitoring the consumption of hydrazine during a reaction.[5][15]

Q3: Are there safer alternatives to using hydrazine directly?

A3: Yes. Given the toxicity and instability of hydrazine, several alternative strategies have been developed to improve safety and handling:

- **In-situ Generation:** This approach avoids handling hydrazine directly by generating it within the reaction mixture from a more stable precursor.[5][16] For example, arylboronic acids can be coupled with protected diimides, followed by deprotection and cyclocondensation in a one-pot process.[16][17]
- **Stable Hydrazine Surrogates:** Sulfonyl hydrazides are stable, solid alternatives that are less hazardous than hydrazine itself.[5] Tosylhydrazone salts are also used as safe precursors for diazo compounds, which can then be used in cycloaddition reactions.[18]
- **Hydrazine-Free Synthesis:** For a completely different approach, [3+2] cycloaddition reactions between diazo compounds and alkynes can form the pyrazole ring without using any hydrazine-based reagent.[5][19]

Q4: What is the proper way to store hydrazine reagents?

A4: Proper storage is absolutely critical to maintain reagent integrity and ensure lab safety.[7]

- **Container:** Store in the original, tightly sealed container.[9][10]
- **Atmosphere:** For optimal stability, store under an inert atmosphere (e.g., nitrogen or argon). [9]

- Location: Keep in a cool, dry, dark, and well-ventilated area designated for hazardous substances.[\[6\]](#)[\[10\]](#)[\[11\]](#)
- Incompatibilities: Store away from acids and oxidizing agents.[\[9\]](#)[\[10\]](#)

Q5: How should I quench unreacted hydrazine in my reaction mixture before workup?

A5: Never dispose of a reaction mixture containing active hydrazine directly into waste. It must be safely quenched first. A widely used and effective method is to add an excess of a simple ketone, such as acetone.[\[5\]](#) The acetone will react with the residual hydrazine to form the much more stable and less hazardous acetone hydrazone, which can then be removed during the workup and purification steps. The quenching reaction should be done cautiously, as it can be exothermic. An alternative, though more hazardous, method is the careful addition of an oxidizing agent like sodium hypochlorite (bleach), which should only be performed by trained personnel with appropriate cooling and containment.[\[5\]](#)[\[10\]](#)

Protocols and Methodologies

Protocol 1: General Procedure for Knorr Pyrazole Synthesis Using Hydrazine Sulfate

This protocol is a standard procedure for synthesizing a simple pyrazole like 3,5-dimethylpyrazole from acetylacetone.

Materials:

- Hydrazine sulfate
- Acetylacetone (1,3-dicarbonyl compound)
- 10% Sodium hydroxide solution
- Ether or Ethyl Acetate for extraction
- Saturated sodium chloride solution (brine)
- Anhydrous magnesium or sodium sulfate

Procedure:

- In a round-bottomed flask equipped with a magnetic stirrer, dissolve hydrazine sulfate (1 equivalent) in the 10% sodium hydroxide solution.
- Cool the flask in an ice bath to approximately 10-15°C.
- Slowly add the 1,3-dicarbonyl compound (1 equivalent) dropwise with vigorous stirring, ensuring the temperature does not rise significantly.
- After the addition is complete, allow the mixture to stir at room temperature for 1-2 hours, or until TLC analysis shows complete consumption of the starting material.
- Dilute the reaction mixture with water to dissolve any precipitated inorganic salts.
- Transfer the mixture to a separatory funnel and extract the product three times with ether or ethyl acetate.
- Combine the organic extracts, wash with brine, and dry over anhydrous sulfate.
- Filter off the drying agent and concentrate the solvent under reduced pressure to obtain the crude pyrazole product, which can be further purified by recrystallization or chromatography.

Protocol 2: Safe Quenching of Residual Hydrazine with Acetone

Procedure:

- After the reaction is deemed complete by TLC or HPLC, cool the reaction mixture in an ice bath.
- Slowly and dropwise, add an excess of acetone (typically 5-10 equivalents relative to the initial amount of hydrazine) to the stirring reaction mixture.
- Monitor the temperature of the reaction. If a significant exotherm is observed, slow the rate of addition.

- Once the addition is complete, remove the ice bath and allow the mixture to stir at room temperature for 30-60 minutes to ensure all residual hydrazine has reacted.
- The reaction mixture is now safe to proceed to aqueous workup.

References

- Technical Support Center: Stability of Hydrazine Reagents in Pyrazole Synthesis - Benchchem. (Source URL:)
- Recent Advances in the Synthesis of Pyrazole Deriv
- Safeguarding Your Research: A Comprehensive Guide to Handling Hydrazine Hydr
- Synthesis and Pharmacological Activities of Pyrazole Deriv
- Application Notes & Protocols: Synthesis of Pyrazole Derivatives from β -Keto Esters - Benchchem. (Source URL:)
- Hydrazine - Risk Management and Safety. (Source URL: [\[Link\]](#))
- Synthesis of Pyrazole - Characteristic Reactions of Pyrazole - Medicinal uses of Pyrazole | PPTX - Slideshare. (Source URL: [\[Link\]](#))
- Purity of Hydrazine Hydrate | PDF | Science & Mathematics - Scribd. (Source URL: [\[Link\]](#))
- Pyrazole synthesis - Organic Chemistry Portal. (Source URL: [\[Link\]](#))
- Hydrazine - Standard Operating Procedure. (Source URL: [\[Link\]](#))
- CB-LSOP-Hydrazines.docx - The Brückner Research Group. (Source URL: [\[Link\]](#))
- New "Green" Approaches to the Synthesis of Pyrazole Derivatives - PMC. (Source URL: [\[Link\]](#))
- Multicomponent syntheses of pyrazoles via (3 + 2)-cyclocondensation and (3 + 2)-cycloaddition key steps - Beilstein Journals. (Source URL: [\[Link\]](#))
- Common Applications and Maintenance of Hydrazine Hydrate. (Source URL: [\[Link\]](#))
- Direct Preparation of N-Substituted Pyrazoles from Primary Aliphatic or Aromatic Amines | The Journal of Organic Chemistry - ACS Publications. (Source URL: [\[Link\]](#))

- Colorimetric Method for Detection of Hydrazine Decomposition in Chemical Decontamination Process - MDPI. (Source URL: [\[Link\]](#))
- the chemical and biochemical degradation of hydrazine - SciSpace. (Source URL: [\[Link\]](#))
- Review of Specific Chemical Interactions for Hydrazine Analysis and Proposed Adaptation for Microsensor Chemical Detection - DTIC. (Source URL: [\[Link\]](#))
- 1. analytical methods - ATSDR. (Source URL: [\[Link\]](#))
- Multicomponent syntheses of pyrazoles via (3 + 2)-cyclocondensation and (3 + 2)-cycloaddition key steps - PMC. (Source URL: [\[Link\]](#))
- HYDRAZINE Method number: Matrix: Target concentration: OSHA PEL: ACGIH TLV: Procedure: Recommended air volume and sampling. (Source URL: [\[Link\]](#))
- Synthesis, Reactions and Medicinal Uses of Pyrazole - Pharmaguideline. (Source URL: [\[Link\]](#))
- Hydrazine - Hach. (Source URL: [\[Link\]](#))
- Knorr Pyrazole Synthesis - J&K Scientific LLC. (Source URL: [\[Link\]](#))
- Use of activated enol ethers in the synthesis of pyrazoles: reactions with hydrazine and a study of pyrazole tautomerism - PMC. (Source URL: [\[Link\]](#))
- Multicomponent Pyrazole Synthesis from Alkynes, Nitriles, and Titanium Imido Complexes via Oxidatively Induced N–N Bond Coupling - PMC. (Source URL: [\[Link\]](#))
- How to determine level of Hydrazine - THINK RXMARINE. (Source URL: [\[Link\]](#))
- Hydrazine - Wikipedia. (Source URL: [\[Link\]](#))

Need Custom Synthesis?

BenchChem offers custom synthesis for rare earth carbides and specific isotopic labeling.

Email: info@benchchem.com or [Request Quote Online](#).

Sources

- [1. mdpi.com](https://www.mdpi.com) [[mdpi.com](https://www.mdpi.com)]
- [2. Synthesis and Pharmacological Activities of Pyrazole Derivatives: A Review - PMC](#) [[pmc.ncbi.nlm.nih.gov](https://pubmed.ncbi.nlm.nih.gov/)]
- [3. pdf.benchchem.com](https://pdf.benchchem.com) [pdf.benchchem.com]
- [4. Pyrazole - Synthesis of Pyrazole - Characteristic Reactions of Pyrazole - Medicinal uses of Pyrazole | PPTX](#) [[slideshare.net](https://www.slideshare.net)]
- [5. pdf.benchchem.com](https://pdf.benchchem.com) [pdf.benchchem.com]
- [6. ehs.ucsb.edu](https://ehs.ucsb.edu) [ehs.ucsb.edu]
- [7. Common Applications and Maintenance of Hydrazine Hydrate - Shenyang East Chemical Science-Tech Co., Ltd. \(ES CHEM Co.,Ltd\)](#) [eschemy.com]
- [8. jk-sci.com](https://jk-sci.com) [jk-sci.com]
- [9. riskmanagement.nd.edu](https://riskmanagement.nd.edu) [riskmanagement.nd.edu]
- [10. benchchem.com](https://benchchem.com) [benchchem.com]
- [11. bruckner.research.uconn.edu](https://bruckner.research.uconn.edu) [bruckner.research.uconn.edu]
- [12. scribd.com](https://scribd.com) [scribd.com]
- [13. mdpi.com](https://www.mdpi.com) [[mdpi.com](https://www.mdpi.com)]
- [14. cdn.hach.com](https://cdn.hach.com) [cdn.hach.com]
- [15. apps.dtic.mil](https://apps.dtic.mil) [apps.dtic.mil]
- [16. BJOC - Multicomponent syntheses of pyrazoles via \(3 + 2\)-cyclocondensation and \(3 + 2\)-cycloaddition key steps](#) [beilstein-journals.org]
- [17. Multicomponent syntheses of pyrazoles via \(3 + 2\)-cyclocondensation and \(3 + 2\)-cycloaddition key steps - PMC](#) [[pmc.ncbi.nlm.nih.gov](https://pubmed.ncbi.nlm.nih.gov/)]
- [18. New "Green" Approaches to the Synthesis of Pyrazole Derivatives - PMC](#) [[pmc.ncbi.nlm.nih.gov](https://pubmed.ncbi.nlm.nih.gov/)]
- [19. Pyrazole synthesis](https://www.organic-chemistry.org) [[organic-chemistry.org](https://www.organic-chemistry.org)]
- To cite this document: BenchChem. [Technical Support Center: Preventing Decomposition of Hydrazine Reagents in Pyrazole Synthesis]. BenchChem, [2026]. [Online PDF]. Available at: [<https://www.benchchem.com/product/b2430873/docs#technical-support-center-preventing-decomposition-of-hydrazine-reagents-in-pyrazole-synthesis>]

Disclaimer & Data Validity:

The information provided in this document is for Research Use Only (RUO) and is strictly not intended for diagnostic or therapeutic procedures. While BenchChem strives to provide accurate protocols, we make no warranties, express or implied, regarding the fitness of this product for every specific experimental setup.

Technical Support: The protocols provided are for reference purposes. Unsure if this reagent suits your experiment?

Need Industrial/Bulk Grade? [Request Custom Synthesis Quote](#)

BenchChem

Our mission is to be the trusted global source of essential and advanced chemicals, empowering scientists and researchers to drive progress in science and industry.

Contact

Address: 3281 E Guasti Rd
Ontario, CA 91761, United States
Phone: (601) 213-4426
Email: info@benchchem.com

[Contact our Ph.D. Support Team for a compatibility check](#)