

Structural Informatics and Pharmacological Profiling of 2-(4-Chlorophenoxy)ethylhydrazine

Author: BenchChem Technical Support Team. **Date:** April 2026

Compound of Interest

Compound Name: 2-(4-Chlorophenoxy)ethylhydrazine

CAS No.: 69782-24-7; 92307-08-9

Cat. No.: B2430593

[Get Quote](#)

Executive Summary

In modern drug development and computational chemistry, the precise identification of molecular entities is foundational to data integrity. Ambiguities in traditional IUPAC nomenclature—especially concerning free bases versus their corresponding salts—often lead to fragmented data across high-throughput screening (HTS) libraries. This whitepaper provides an in-depth technical analysis of **2-(4-Chlorophenoxy)ethylhydrazine**, a biologically active hydrazine derivative. By standardizing its identity through the IUPAC International Chemical Identifier (InChI) and its hashed counterpart (InChIKey), researchers can seamlessly integrate pharmacological, synthetic, and safety data across global databases.

Chemical Identity and Structural Informatics

A critical failure point in cheminformatics is the conflation of a free base compound with its salt form. **2-(4-Chlorophenoxy)ethylhydrazine** is most commonly handled in the laboratory as a hydrochloride salt to improve stability and aqueous solubility[1]. However, computational docking studies and target-binding assays inherently rely on the free base structure.

The InChI algorithm resolves this by generating a deterministic, layered string that maps molecular connectivity, stereochemistry, and isotopic composition. Because the InChI string can be unwieldy for database indexing, it is subjected to a SHA-256 cryptographic hash to produce a 27-character InChIKey[2].

Quantitative Chemical Properties

The following table summarizes the structural identifiers and physical properties, explicitly distinguishing between the free base and the hydrochloride salt to ensure database querying accuracy.

Property	Free Base	Hydrochloride Salt
Molecular Formula	C8H11ClN2O	C8H12ClN2O (C8H11ClN2O·HCl)
Molecular Weight	186.64 g/mol	223.10 g/mol
Monoisotopic Mass	186.05598 Da	222.03267 Da
CAS Registry Number	Not widely indexed	69782-24-7[3] / 92307-08-9[1]
Standard InChI String	InChI=1S/C8H11ClN2O/c9-7-1-3-8(4-2-7)12-6-5-11-10/h1-4,11H,5-6,10H2	InChI=1S/C8H11ClN2O.ClH/c9-7-1-3-8(4-2-7)12-6-5-11-10;/h1-4,11H,5-6,10H2;1H[4]
Standard InChIKey	VFIPEQXYJLYCV-UHFFFAOYSA-N[2]	PQTJCBUNRRSIQY-UHFFFAOYSA-N[4]

Pharmacological Relevance & Mechanism of Action

Hydrazine derivatives structurally homologous to **2-(4-Chlorophenoxy)ethylhydrazine** are historically classified as Monoamine Oxidase Inhibitors (MAOIs). The inclusion of the 4-chlorophenoxy moiety significantly increases the molecule's lipophilicity, enhancing its ability to cross the blood-brain barrier (BBB) compared to simpler hydrazines.

Causality of Inhibition: The mechanism of action relies on the catalytic machinery of the MAO enzyme itself. When the hydrazine moiety enters the active site, the enzyme attempts to oxidize it. Instead of a standard turnover, this enzymatic oxidation converts the hydrazine into a

highly reactive diazene intermediate. This intermediate immediately acts as an electrophile, forming an irreversible covalent bond with the flavin adenine dinucleotide (FAD) cofactor. This self-validating "suicide inhibition" permanently inactivates the enzyme, leading to an accumulation of monoamine neurotransmitters (e.g., serotonin, dopamine).

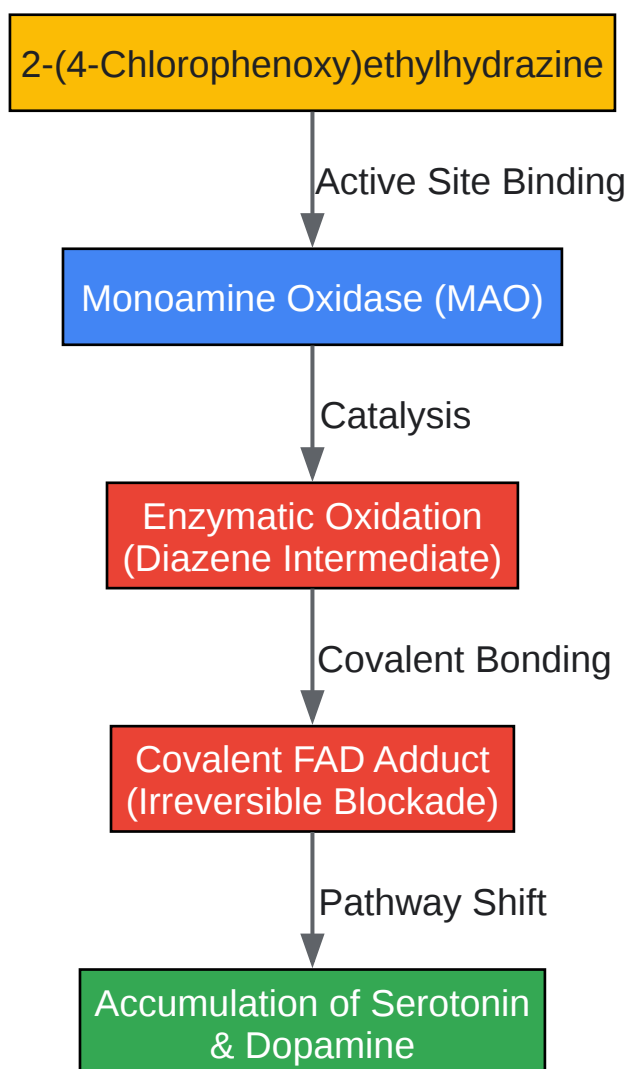

[Click to download full resolution via product page](#)

Fig 1: Mechanism of irreversible MAO inhibition by hydrazine derivatives via covalent FAD adduction.

Experimental Workflow: Synthesis and Validation

Direct alkylation of free hydrazine hydrate with an alkyl halide frequently results in over-alkylation, yielding symmetric bis-alkylated impurities. To establish a self-validating, high-yield

system, the following protocol utilizes a tert-butyloxycarbonyl (Boc) protection strategy. The steric bulk of the Boc group strictly limits the reaction to mono-alkylation.

Step-by-Step Methodology

Step 1: Etherification (Precursor Synthesis)

- Dissolve 4-chlorophenol (1.0 eq) and anhydrous K_2CO_3 (1.5 eq) in dimethylformamide (DMF).
- Add 1,2-dibromoethane (3.0 eq) dropwise. Rationale: A large excess of the dihalide prevents the formation of dimeric ether byproducts.
- Heat the mixture to 70°C and stir for 8 hours.
- Quench with water, extract with ethyl acetate (EtOAc), wash with brine to remove DMF, and concentrate in vacuo to yield 1-bromo-2-(4-chlorophenoxy)ethane.

Step 2: Protected Hydrazine Substitution

- Dissolve the crude bromide intermediate (1.0 eq) in acetonitrile.
- Add tert-butyl carbazate (Boc-hydrazine, 1.2 eq) and K_2CO_3 (1.5 eq).
- Reflux for 12 hours. Rationale: The Boc group's steric hindrance ensures the nitrogen nucleophile only attacks a single equivalent of the alkyl bromide.
- Purify the mixture via flash column chromatography (Hexanes/EtOAc) to isolate the pure Boc-protected intermediate.

Step 3: Deprotection and Salt Precipitation

- Dissolve the purified intermediate in a 4M solution of HCl in dioxane.
- Stir at room temperature for 2 hours. Rationale: The acidic environment cleaves the Boc group, releasing gaseous CO_2 and isobutylene. The evolution of gas drives the reaction to absolute completion (Le Chatelier's principle).

- Filter the resulting white precipitate and wash with cold diethyl ether to yield pure **2-(4-Chlorophenoxy)ethylhydrazine hydrochloride**[3].

Analytical Validation

To ensure trustworthiness, the synthesized compound must be validated against its theoretical parameters:

- LC-MS: Must confirm the exact monoisotopic mass of the free base (m/z $[M+H]^+ = 187.06$) [2].
- $^1\text{H-NMR}$ (DMSO-d_6): Must display the characteristic AA'BB' doublet pattern of a para-substituted aromatic ring (two doublets around 6.9 and 7.3 ppm, $J \approx 9$ Hz) and the ethyl linker (two distinct triplets around 4.1 and 3.2 ppm).

Cheminformatics Integration

In drug development, linking the physical synthesis of **2-(4-Chlorophenoxy)ethylhydrazine** to its in silico profile requires the InChIKey. Because the InChIKey is a fixed 27-character string, it acts as a universal primary key in relational databases, bypassing the parsing errors associated with SMILES strings or proprietary naming conventions.

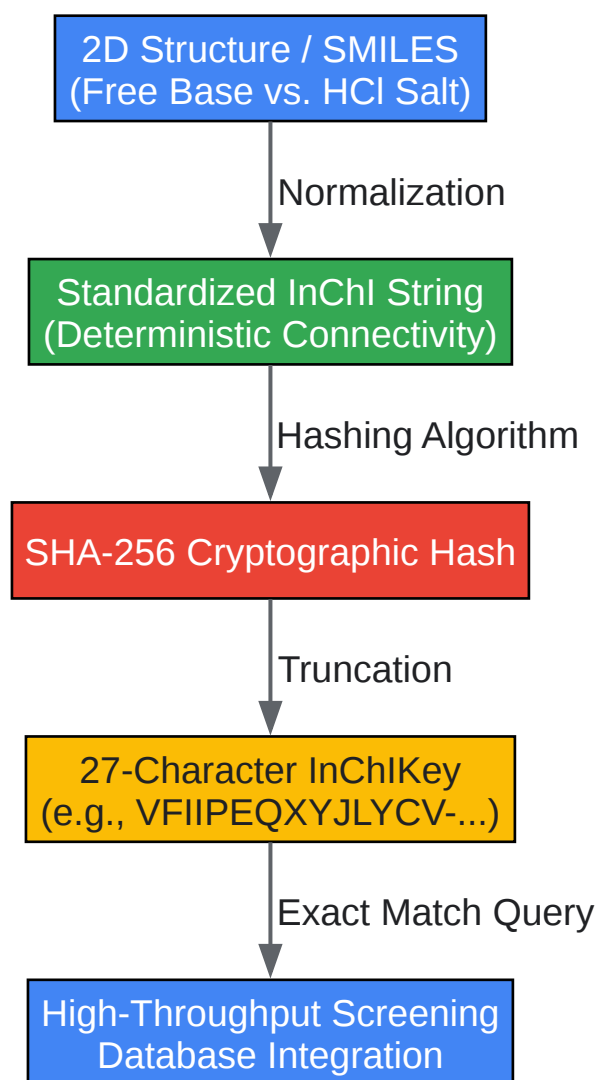

[Click to download full resolution via product page](#)

Fig 2: Cheminformatics data integration workflow utilizing InChIKey for exact database matching.

References

- 001chemical. "**2-(4-chlorophenoxy)ethylhydrazine** Hydrochloride | CAS 69782-24-7". URL: [\[Link\]](#)
- PubChemLite (Université du Luxembourg). "VFIIPEQXYJLYCV-UHFFFAOYSA-N - Explore". URL: [\[Link\]](#)

Need Custom Synthesis?

BenchChem offers custom synthesis for rare earth carbides and specific isotopic labeling.

Email: info@benchchem.com or [Request Quote Online](#).

Sources

- 1. scbt.com [scbt.com]
- 2. PubChemLite - VFIIPEQXYJLYCV-UHFFFAOYSA-N - Explore [pubchemlite.lcsb.uni.lu]
- 3. 001chemical.com [001chemical.com]
- 4. [2-(4-chlorophenoxy)ethyl]hydrazine hydrochloride | 69782-24-7 [sigmaaldrich.com]
- To cite this document: BenchChem. [Structural Informatics and Pharmacological Profiling of 2-(4-Chlorophenoxy)ethylhydrazine]. BenchChem, [2026]. [Online PDF]. Available at: [<https://www.benchchem.com/product/b2430593/docs#structural-informatics-and-pharmacological-profiling-of-2-4-chlorophenoxy-ethylhydrazine>]

Disclaimer & Data Validity:

The information provided in this document is for Research Use Only (RUO) and is strictly not intended for diagnostic or therapeutic procedures. While BenchChem strives to provide accurate protocols, we make no warranties, express or implied, regarding the fitness of this product for every specific experimental setup.

Technical Support: The protocols provided are for reference purposes. Unsure if this reagent suits your experiment?

Need Industrial/Bulk Grade? [Request Custom Synthesis Quote](#)

BenchChem

Our mission is to be the trusted global source of essential and advanced chemicals, empowering scientists and researchers to drive progress in science and industry.

Contact

Address: 3281 E Guasti Rd

Ontario, CA 91761, United States

Phone: (601) 213-4426

Email: info@benchchem.com

[Contact our Ph.D. Support Team for a compatibility check](#)