

# A Comparative Guide to Cross-Reactivity Profiling of Thiophene-Based Kinase Inhibitors

**Author:** BenchChem Technical Support Team. **Date:** April 2026

## Compound of Interest

Compound Name: *5-Methanesulfonylthiophene-2-carbonitrile*

CAS No.: 859794-80-2

Cat. No.: B2419943

[Get Quote](#)

For Researchers, Scientists, and Drug Development Professionals

In the landscape of kinase inhibitor discovery, the thiophene scaffold has emerged as a privileged structure, forming the core of numerous potent and selective therapeutic agents. However, achieving absolute target specificity remains a formidable challenge. Off-target activities can lead to unforeseen toxicities or, in some cases, beneficial polypharmacology. A thorough understanding of a compound's cross-reactivity profile is therefore paramount for advancing a candidate through the drug development pipeline.

This guide provides a comparative analysis of the cross-reactivity profiles of several kinase inhibitors, with a focus on compounds containing the thiophene moiety. We will delve into the experimental methodologies used to generate these profiles, present comparative data for selected compounds, and explore the signaling pathways they modulate. As specific cross-reactivity data for **5-Methanesulfonylthiophene-2-carbonitrile** is not extensively available in the public domain, this guide will use well-characterized thiophene-containing inhibitors and other relevant comparators to illustrate the principles and techniques of cross-reactivity profiling.

## The Imperative of Kinase Selectivity

Protein kinases, comprising a family of over 500 enzymes in the human kinome, are central regulators of a vast array of cellular processes.[1] Their structural similarities, particularly within the ATP-binding pocket, present a significant hurdle in the design of truly selective inhibitors.[1] A lack of selectivity can result in off-target effects, leading to toxicity.[2] Conversely, a multi-targeted inhibitor can sometimes offer a therapeutic advantage, for instance, by simultaneously blocking redundant signaling pathways in cancer.[3] Therefore, a comprehensive assessment of an inhibitor's interactions across the kinome is a critical step in its preclinical evaluation.

## Comparative Cross-Reactivity Analysis

To illustrate the diversity in kinase inhibitor selectivity, this section presents a comparative analysis of several compounds. While a comprehensive dataset for a series of structurally related thiophene-based inhibitors is not readily available, we can draw valuable insights from the KINOMEScan™ data of well-characterized inhibitors, including some with thiophene or related heterocyclic cores.

The data below is presented as "Percent of Control" (%Ctrl), where a lower number indicates stronger binding of the inhibitor to the kinase.

Kinase Target	AZD7762 (Thiophenecarboxamide Urea) (%Ctrl @ 10 $\mu$ M)[4]	Sorafenib (Aryl Urea) (%Ctrl @ 10 $\mu$ M)	Lapatinib (Quinazoline) (%Ctrl @ 10 $\mu$ M)[5]	Gefitinib (Quinazoline) (Kd in nM)[4]
Primary Targets				
CHEK1 (CHK1)	<1	98	99	>10000
CHEK2 (CHK2)	<1	97	99	>10000
BRAF	99	0.5	99	>10000
VEGFR2 (KDR)	99	<1	99	>10000
EGFR	99	99	<1	3.3
ERBB2 (HER2)	99	99	<1	1000
Selected Off-Targets				
AAK1	99	1.5	99	>10000
ABL1	99	1	99	>10000
AURKA	99	99	99	>10000
CDK1	>100	99	99	>10000
FLT3	99	<1	99	>10000
KIT	99	<1	99	>10000
p38 $\alpha$ (MAPK14)	99	99	99	>10000
PIM1	99	99	99	>10000
SRC	99	1.5	99	>10000

Data Interpretation:

- AZD7762, a thiophenecarboxamide urea derivative, demonstrates high selectivity for its primary targets, CHK1 and CHK2, with minimal interaction with other kinases in this panel at a high concentration.[4][6]
- Sorafenib is a multi-kinase inhibitor, exhibiting potent binding to BRAF, VEGFR2, FLT3, and KIT, among others.[7] This broad-spectrum activity is integral to its clinical efficacy in various cancers.[8]
- Lapatinib is a dual inhibitor of EGFR and ERBB2 (HER2), with high selectivity against other kinases.[5]
- Gefitinib shows high potency for its primary target, EGFR, with significantly weaker binding to other kinases.[4][9]

## Key Signaling Pathways

Understanding the signaling pathways in which a kinase target is involved is crucial for interpreting the biological consequences of its inhibition. Below are simplified diagrams of three major signaling pathways often targeted by kinase inhibitors.

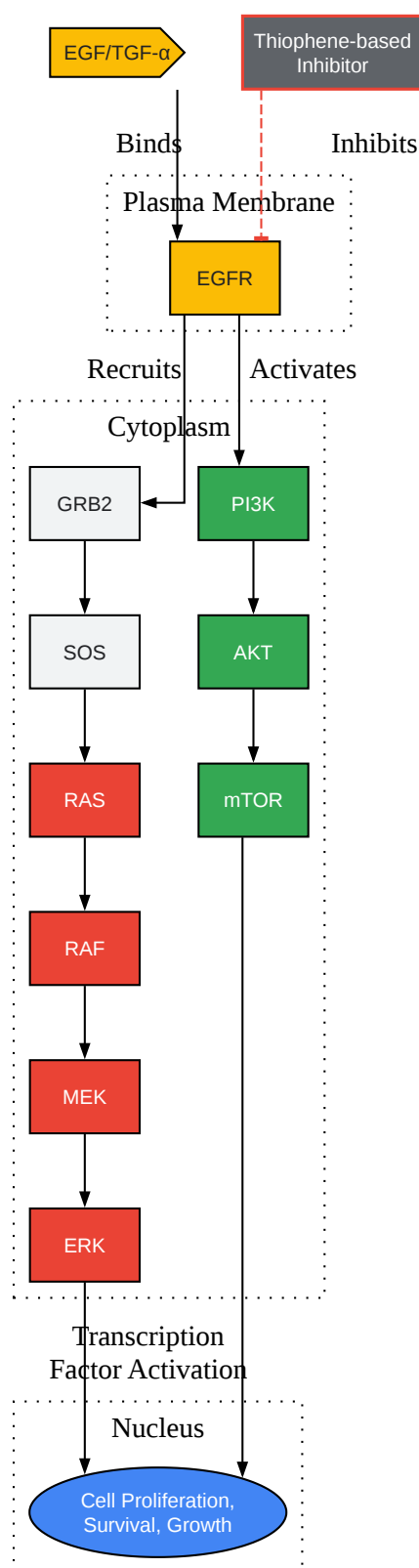

[Click to download full resolution via product page](#)

Caption: Simplified EGFR signaling pathway and its inhibition.[3][8][10][11]

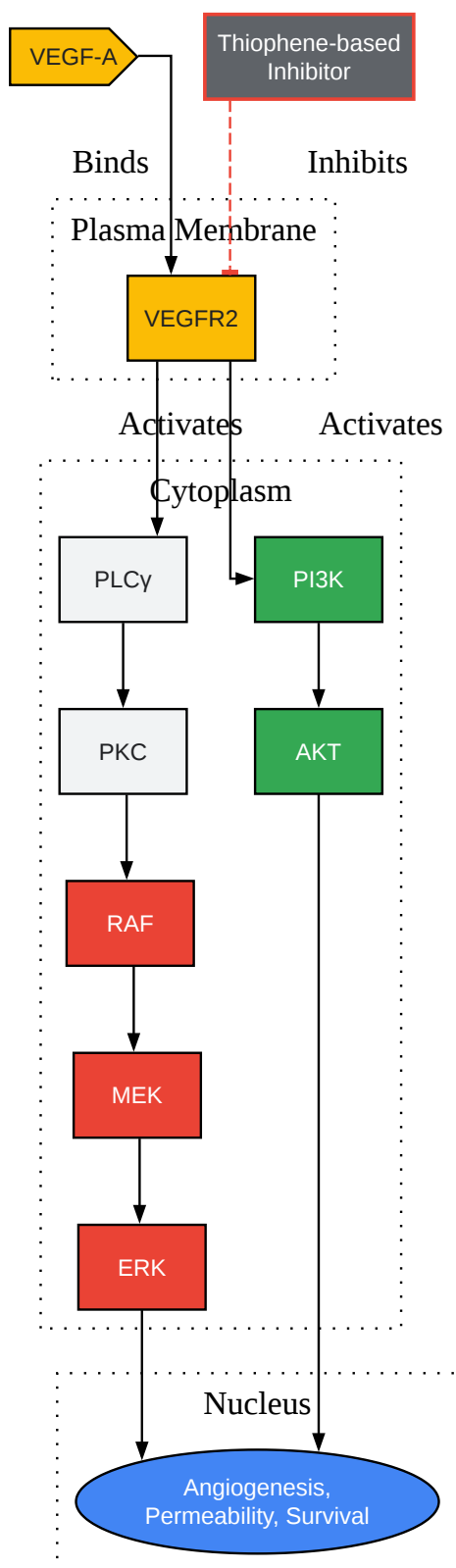

[Click to download full resolution via product page](#)

Caption: Simplified VEGFR2 signaling pathway and its inhibition.[12][13][14][15][16]

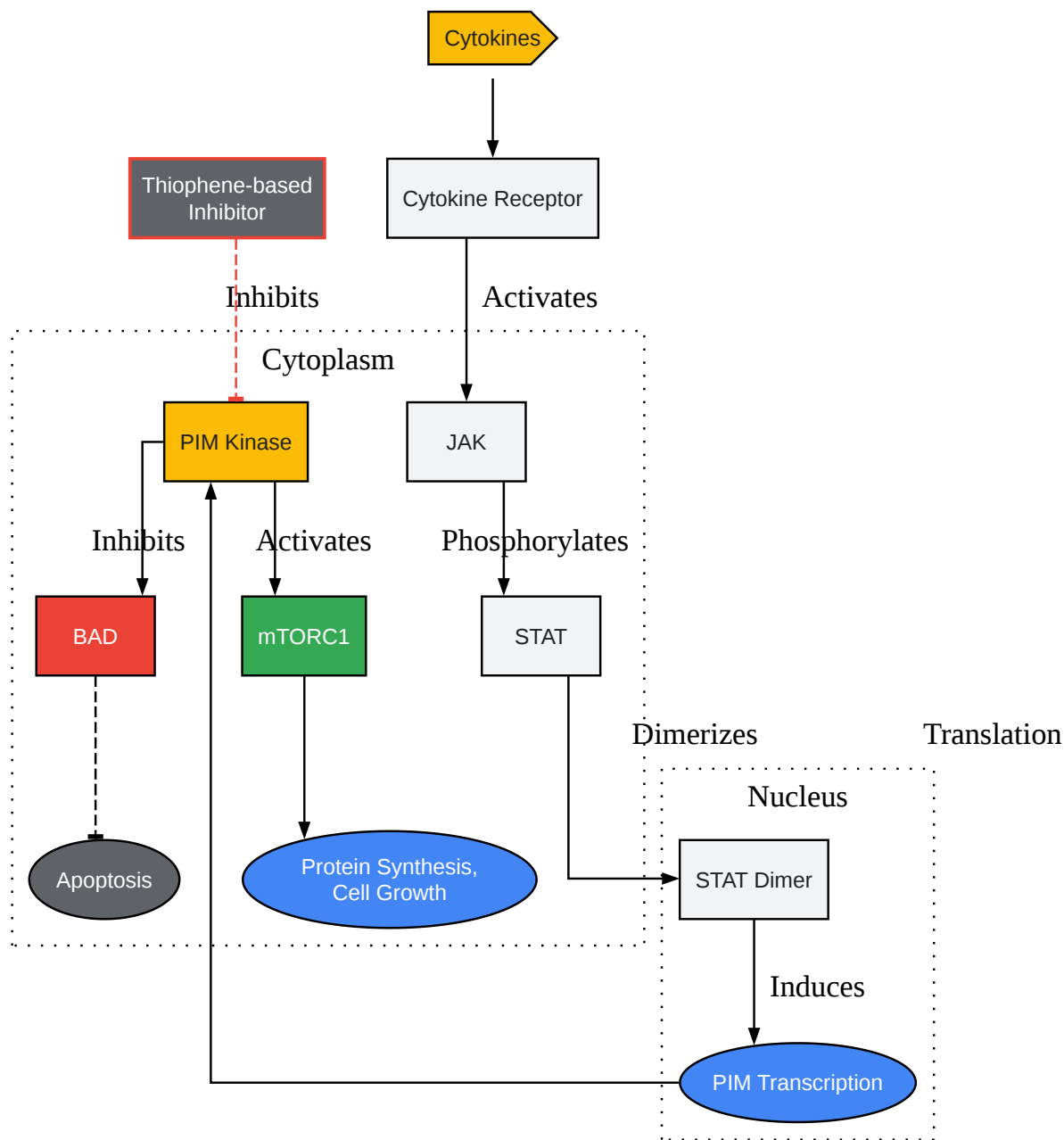

[Click to download full resolution via product page](#)

Caption: Simplified PIM kinase signaling pathway and its inhibition.[17][18][19][20][21]

## Experimental Protocols for Cross-Reactivity Profiling

A robust assessment of kinase inhibitor selectivity relies on a combination of in vitro biochemical assays and cell-based target engagement studies. Here, we detail three widely used methodologies.

## ADP-Glo™ Kinase Assay (Biochemical Activity)

The ADP-Glo™ Kinase Assay is a luminescent, homogeneous assay that quantifies the amount of ADP produced during a kinase reaction.<sup>[22][23][24]</sup> It is a versatile platform for determining inhibitor potency (IC<sub>50</sub>) and can be used to screen compounds against a panel of kinases.

Principle: The assay is performed in two steps. First, the kinase reaction is stopped, and the remaining ATP is depleted. Second, the ADP generated is converted back to ATP, which is then used in a luciferase/luciferin reaction to produce a light signal proportional to the kinase activity.

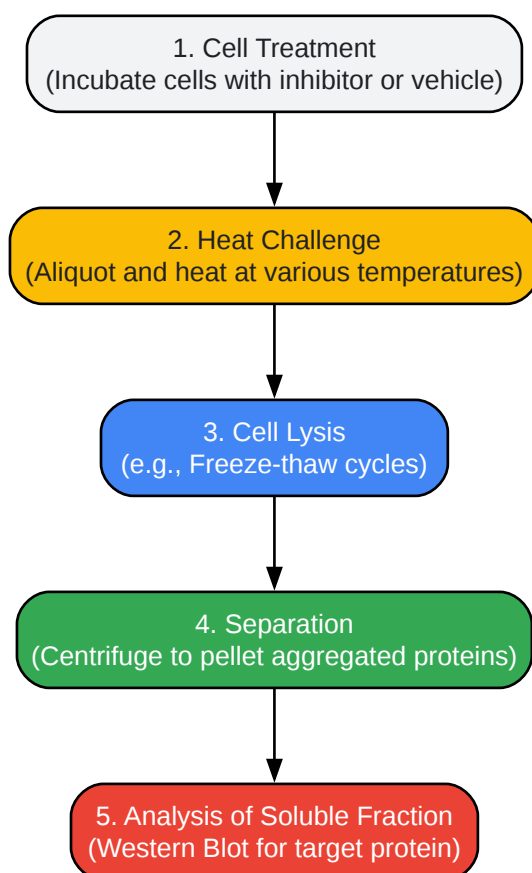

[Click to download full resolution via product page](#)

Caption: Cellular Thermal Shift Assay (CETSA®) Workflow.

Step-by-Step Protocol:

- **Cell Culture and Treatment:** Culture cells to the desired confluency. Treat the cells with the test compound or vehicle (e.g., DMSO) for a specified time (e.g., 1-2 hours) at 37°C. [25]2. **Heat Challenge:** Aliquot the cell suspension into PCR tubes. Heat the tubes at a range of temperatures (e.g., 40°C to 70°C) for a short period (e.g., 3 minutes) using a thermal cycler. [25]3. **Cell Lysis:** Lyse the cells, for example, by performing three freeze-thaw cycles using liquid nitrogen and a 37°C water bath. [25]4. **Separation of Soluble and Aggregated Proteins:** Centrifuge the lysates at high speed (e.g., 20,000 x g) for 20 minutes at 4°C to pellet the denatured and aggregated proteins. [25]5. **Analysis of Soluble Fraction:** Carefully collect the supernatant. Determine the protein concentration and analyze the levels of the target protein by Western blotting using a specific antibody.
- **Data Analysis:** Quantify the band intensities from the Western blot. Plot the percentage of soluble protein against the temperature to generate melting curves and determine the melting temperature (T<sub>m</sub>).

## KiNativ™ (In-situ Kinase Profiling)

KiNativ™ is a chemoproteomics platform that enables the profiling of kinase inhibitor interactions directly in cell or tissue lysates. [26][27]It provides a snapshot of the "active" kinome and how it is modulated by an inhibitor.

**Principle:** A biotin-labeled, ATP- or ADP-mimicking probe is used to covalently label the active site of kinases in a lysate. [26]If a kinase is bound by an inhibitor, the probe cannot access the active site, and labeling is reduced. The extent of labeling is quantified by mass spectrometry.

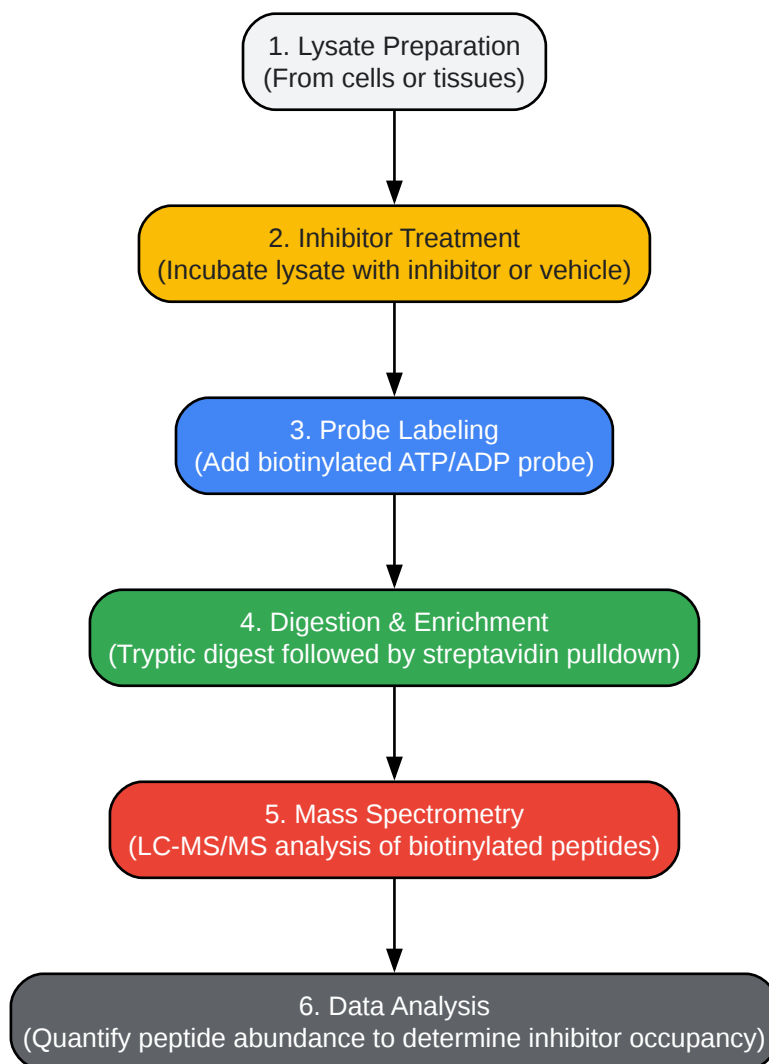

[Click to download full resolution via product page](#)

Caption: KiNativ™ Experimental Workflow.

Step-by-Step Protocol:

- Lysate Preparation: Prepare a native protein lysate from cells or tissues under conditions that preserve kinase activity.
- Inhibitor Incubation: Treat the lysate with the test compound at various concentrations or with a vehicle control.
- Probe Labeling: Add the biotinylated acyl-phosphate ATP/ADP probe to the lysate and incubate to allow for covalent labeling of active kinases. [26]4. Protein Digestion: Denature

the proteins and digest them into peptides using trypsin.

- Enrichment of Labeled Peptides: Use streptavidin-coated beads to enrich for the biotin-labeled peptides.
- LC-MS/MS Analysis: Analyze the enriched peptides by liquid chromatography-tandem mass spectrometry (LC-MS/MS) to identify and quantify the labeled kinase active-site peptides.
- Data Analysis: Compare the abundance of labeled peptides between the inhibitor-treated and vehicle-treated samples to determine the inhibitor's potency and selectivity across the profiled kinome.

## Conclusion

The cross-reactivity profiling of kinase inhibitors is a multifaceted process that requires a combination of biochemical and cell-based assays. While specific data for **5-Methanesulfonylthiophene-2-carbonitrile** is not yet widely available, the principles and methodologies outlined in this guide provide a robust framework for its evaluation. By employing techniques such as the ADP-Glo™ assay, CETSA®, and KiNativ™, researchers can build a comprehensive understanding of a compound's selectivity profile. This knowledge is essential for interpreting its biological effects, predicting potential liabilities, and ultimately guiding its development as a safe and effective therapeutic agent. The thiophene scaffold continues to be a valuable starting point for the design of potent kinase inhibitors, and a thorough characterization of their cross-reactivity will be key to unlocking their full therapeutic potential.

## References

- Oda, K., Matsuoka, Y., Funahashi, A., & Kitano, H. (2005). A comprehensive pathway map of epidermal growth factor receptor signaling. *Molecular Systems Biology*, 1, 2005.0010. [8]9. IUPHAR/BPS Guide to PHARMACOLOGY. (n.d.). sorafenib. Retrieved from [[Link](#)]
- IntechOpen. (2021, July 12). Protein Kinase Inhibitors - Selectivity or Toxicity? Retrieved from [[Link](#)]
- bioRxiv. (2021, March 19). Correlation analysis of target selectivity and side effects of FDA-approved kinase inhibitors. Retrieved from [[Link](#)]

- Bubici, C., & Papa, S. (2014). EGFR signaling in cancer: a tale of two tides. *Signal Transduction and Targeted Therapy*, 4(1), 1-10.
- Molina, D. M., et al. (2014). The cellular thermal shift assay for evaluating drug target interactions in cells. *Nature Protocols*, 9(9), 2101-2117. [28]20. ResearchGate. (n.d.). Schematic diagram of EGFR signaling pathway.[29] Growth factor binding.... Retrieved from [Link] [30]21. University of Cambridge. (n.d.). Application of the cellular thermal shift assay (CETSA) to validate drug target engagement in platelets. Retrieved from [Link]
- Scarpelli, R., et al. (2012). Design, Synthesis, and Structure-Activity Relationship Studies of Thiophene- 3-carboxamide Derivatives as Dual Inhibitors of the c-Jun N-Terminal Kinase. *Journal of Medicinal Chemistry*, 55(17), 7818–7832.
- Patricelli, M. P., et al. (2011). In Situ Kinase Profiling Reveals Functionally Relevant Properties of Native Kinases. *Chemistry & Biology*, 18(6), 699-710. [26]27. ResearchGate. (n.d.). The KiNativ approach to kinase inhibitor profiling. ATP-biotin can bind.... Retrieved from [Link] [27]28. MDPI. (2023, August 8). Pim Kinases. Retrieved from [Link] [17]29. Kris, M. G., et al. (2003). Efficacy of Gefitinib, an Inhibitor of the Epidermal Growth Factor Receptor Tyrosine Kinase, in Symptomatic Patients With Non–Small Cell Lung Cancer. *JAMA*, 290(16), 2149–2158.
- ClinPGx. (n.d.). Sorafenib Pharmacodynamics. Retrieved from [Link]
- HMS LINCS Project. (n.d.). Kinase inhibitor pathways. Retrieved from [Link]
- HMS LINCS Project. (2016, September 15). KiNativ data. Retrieved from [Link]
- F1000Research. (2017, June 26). Recent advances in methods to assess the activity of the kinome. Retrieved from [Link]
- ICE Bioscience. (n.d.). Kinase Panel Screening | Kinase Selectivity Profiling Services. Retrieved from [Link]

### Need Custom Synthesis?

BenchChem offers custom synthesis for rare earth carbides and specific isotopic labeling.

Email: [info@benchchem.com](mailto:info@benchchem.com) or [Request Quote Online](#).

## Sources

- [1. Different chemical proteomic approaches to identify the targets of lapatinib - PMC \[pmc.ncbi.nlm.nih.gov\]](#)
- [2. researchgate.net \[researchgate.net\]](#)
- [3. mdpi.com \[mdpi.com\]](#)
- [4. lincportal.ccs.miami.edu \[lincportal.ccs.miami.edu\]](#)
- [5. lincportal.ccs.miami.edu \[lincportal.ccs.miami.edu\]](#)
- [6. accessdata.fda.gov \[accessdata.fda.gov\]](#)
- [7. file.medchemexpress.com \[file.medchemexpress.com\]](#)
- [8. A comprehensive pathway map of epidermal growth factor receptor signaling - PMC \[pmc.ncbi.nlm.nih.gov\]](#)
- [9. gefitinib | Ligand page | IUPHAR/BPS Guide to PHARMACOLOGY \[guidetopharmacology.org\]](#)
- [10. creative-diagnostics.com \[creative-diagnostics.com\]](#)
- [11. EGFR interactive pathway | Abcam \[abcam.com\]](#)
- [12. commerce.bio-rad.com \[commerce.bio-rad.com\]](#)
- [13. researchgate.net \[researchgate.net\]](#)
- [14. Frontiers | Molecular Bases of VEGFR-2-Mediated Physiological Function and Pathological Role \[frontiersin.org\]](#)
- [15. Advances in the molecular signaling mechanisms of VEGF/VEGFR2 in fundus neovascularization disease \(Review\) - PMC \[pmc.ncbi.nlm.nih.gov\]](#)
- [16. VEGFA-VEGFR2 signaling | Pathway - PubChem \[pubchem.ncbi.nlm.nih.gov\]](#)
- [17. encyclopedia.pub \[encyclopedia.pub\]](#)
- [18. bocsci.com \[bocsci.com\]](#)
- [19. Protein kinase PIM2: A simple PIM family kinase with complex functions in cancer metabolism and therapeutics \[jcancer.org\]](#)
- [20. mdpi.com \[mdpi.com\]](#)
- [21. Protein kinase PIM2: A simple PIM family kinase with complex functions in cancer metabolism and therapeutics - PMC \[pmc.ncbi.nlm.nih.gov\]](#)
- [22. promega.com \[promega.com\]](#)

- [23. promega.com \[promega.com\]](#)
- [24. ADP-Glo™ Kinase Assay Protocol \[worldwide.promega.com\]](#)
- [25. benchchem.com \[benchchem.com\]](#)
- [26. In Situ Kinase Profiling Reveals Functionally Relevant Properties of Native Kinases - PMC \[pmc.ncbi.nlm.nih.gov\]](#)
- [27. researchgate.net \[researchgate.net\]](#)
- [28. scispace.com \[scispace.com\]](#)
- [29. pdf.benchchem.com \[pdf.benchchem.com\]](#)
- [30. researchgate.net \[researchgate.net\]](#)
- To cite this document: BenchChem. [A Comparative Guide to Cross-Reactivity Profiling of Thiophene-Based Kinase Inhibitors]. BenchChem, [2026]. [Online PDF]. Available at: [\[https://www.benchchem.com/product/b2419943/docs#a-comparative-guide-to-cross-reactivity-profiling-of-thiophene-based-kinase-inhibitors\]](https://www.benchchem.com/product/b2419943/docs#a-comparative-guide-to-cross-reactivity-profiling-of-thiophene-based-kinase-inhibitors)

---

#### Disclaimer & Data Validity:

The information provided in this document is for Research Use Only (RUO) and is strictly not intended for diagnostic or therapeutic procedures. While BenchChem strives to provide accurate protocols, we make no warranties, express or implied, regarding the fitness of this product for every specific experimental setup.

**Technical Support:** The protocols provided are for reference purposes. Unsure if this reagent suits your experiment?

**Need Industrial/Bulk Grade?** [Request Custom Synthesis Quote](#)

## BenchChem

Our mission is to be the trusted global source of essential and advanced chemicals, empowering scientists and researchers to drive progress in science and industry.

#### Contact

Address: 3281 E Guasti Rd

Ontario, CA 91761, United States

Phone: (601) 213-4426

Email: [info@benchchem.com](mailto:info@benchchem.com)

Contact our Ph.D. Support Team for a compatibility check