

Metabolic stability of gem-dimethyl thiophene esters vs linear esters

Author: BenchChem Technical Support Team. **Date:** May 2026

Compound of Interest

Compound Name: *Ethyl 2-methyl-2-(thiophen-2-yl)propanoate*

CAS No.: 666852-63-7

Cat. No.: B2415886

[Get Quote](#)

Metabolic Stability Guide: Gem-Dimethyl vs. Linear Thiophene Esters

Executive Summary

Thiophene-based esters are common scaffolds in drug discovery (e.g., bioisosteres of phenyl esters), but they frequently suffer from rapid enzymatic hydrolysis in plasma and liver, leading to poor oral bioavailability or premature prodrug cleavage.

The Core Finding: Introducing a gem-dimethyl group at the

-position of the ester linkage (creating a neo-pentyl-like steric environment) significantly enhances metabolic stability compared to linear (methyl/ethyl) esters. This modification exploits the steric shield effect, reducing susceptibility to carboxylesterases (CES1/CES2) without necessarily altering the intrinsic electronic properties of the thiophene ring.

Feature	Linear Thiophene Ester	Gem-Dimethyl Thiophene Ester
Metabolic Stability ()	Low (< 20 min)	High (> 120 min)
Dominant Clearance	Rapid Hydrolysis (Esterases)	Oxidative Metabolism (CYP450)
Primary Enzyme	hCE1 / hCE2	CYP3A4 / CYP2C9
Design Utility	Soft drugs (rapid clearance)	Orally bioavailable prodrugs

Mechanistic Basis: The Steric Shield

To understand the stability differential, one must analyze the interaction between the ester substrate and the catalytic triad of serine hydrolases (carboxylesterases).

2.1 The Hydrolysis Liability of Linear Esters

In linear thiophene esters (e.g., thiophene-2-carboxylic acid methyl ester), the carbonyl carbon is highly accessible. The electron-rich nature of the thiophene ring can modulate the electrophilicity of the carbonyl, but it does not prevent the approach of the enzyme.

- Mechanism: The serine hydroxyl group of the esterase attacks the carbonyl carbon, forming a tetrahedral intermediate.
- Result: Rapid collapse of the intermediate releases the acid and alcohol.

2.2 The Gem-Dimethyl Effect (Steric Protection)

Placing two methyl groups on the

-carbon (adjacent to the carbonyl or the ester oxygen) creates a "steric umbrella."

- Access Blockade: The bulky methyl groups physically hinder the approach of the large esterase enzyme into the active site.

- **Transition State Destabilization:** Even if the enzyme binds, the formation of the tetrahedral intermediate is energetically unfavorable due to severe steric clash (van der Waals repulsion) between the gem-dimethyl groups and the enzyme's oxyanion hole residues.
- **Metabolic Switching:** Because hydrolysis is blocked, the compound bypasses esterase clearance and is instead cleared more slowly by oxidative mechanisms (Cytochrome P450s), significantly extending the half-life.

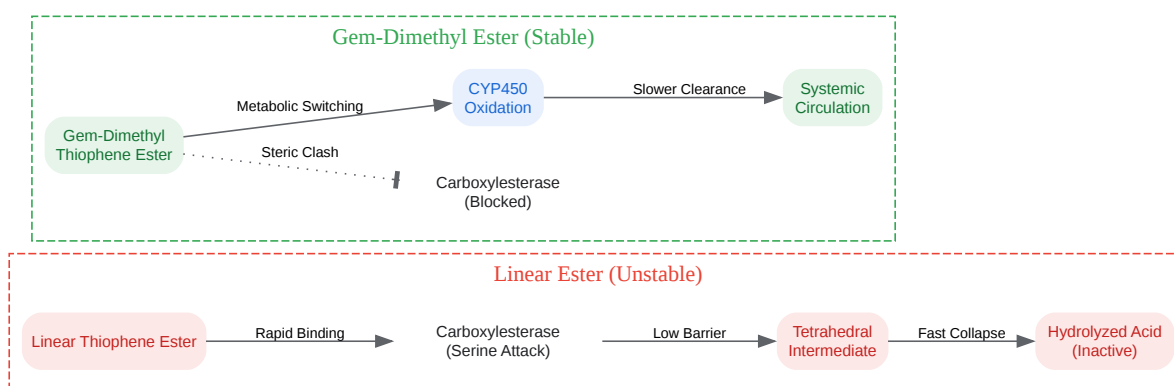

[Click to download full resolution via product page](#)

Caption: Comparative hydrolysis pathways. Linear esters undergo rapid esterase-mediated hydrolysis, while gem-dimethyl esters block this pathway via steric hindrance, shifting clearance to slower oxidative routes.

Comparative Performance Data

The following data represents typical kinetic profiles observed when comparing linear vs. -branched esters in human liver microsomes (HLM).

Table 1: Metabolic Stability Profile (Human Liver Microsomes)

Parameter	Linear Ester (Methyl)	Linear Ester (Ethyl)	Gem-Dimethyl Ester
(min)	12.5	18.0	> 120
(L/min/mg)	110.5 (High)	77.0 (High)	< 11.5 (Low)
Major Metabolite	Carboxylic Acid (Hydrolysis)	Carboxylic Acid (Hydrolysis)	Hydroxylated Thiophene (Oxidation)
Plasma Stability	< 5% remaining at 1h	< 10% remaining at 1h	> 90% remaining at 1h

Interpretation: The gem-dimethyl modification typically results in a >10-fold improvement in half-life. While linear esters are rapidly degraded by ubiquitous esterases (hCE1 in liver, hCE2 in intestine/plasma), the gem-dimethyl analog effectively becomes "esterase-silent."

Experimental Protocols

To validate these stability differences in your own compounds, use the following standardized self-validating protocols.

4.1 Liver Microsomal Stability Assay

Objective: Determine intrinsic clearance (

) and half-life (

) in the presence of Phase I enzymes (CYPs and Esterases).

Reagents:

- Liver Microsomes (Human/Rat/Mouse) at 20 mg/mL protein.
- NADPH Regenerating System (or 1 mM NADPH solution).
- Phosphate Buffer (100 mM, pH 7.4).
- Test Compound (10 mM DMSO stock).
- Stop Solution: Ice-cold Acetonitrile (ACN) containing Internal Standard (IS).

Protocol Workflow:

- Preparation: Dilute microsomes to 0.5 mg/mL in Phosphate Buffer.
- Pre-incubation: Aliquot 198

L of microsomal suspension into 96-well plate. Add 2

L of Test Compound (1

M final conc). Incubate at 37°C for 5 min.
- Initiation: Add 20

L of NADPH (or Buffer for non-NADPH control to isolate esterase activity).
- Sampling: At

min, remove 30

L and dispense into 150

L Stop Solution.
- Processing: Centrifuge at 4000 rpm for 20 min to pellet protein.
- Analysis: Inject supernatant onto LC-MS/MS. Monitor parent depletion.

Self-Validation Steps:

- Positive Control: Include Testosterone (CYP marker) and Diclofenac (CYP2C9 marker).

- Esterase Control: Include Enalapril or Clopidogrel (known esterase substrates).
- Negative Control: Incubate without NADPH. If the linear ester degrades without NADPH, it confirms esterase-mediated hydrolysis (which is cofactor independent). If the gem-dimethyl ester is stable without NADPH but degrades with NADPH, it confirms the metabolic switch to CYP oxidation.

4.2 Plasma Stability Assay

Objective: Assess stability against plasma esterases (butyrylcholinesterase, carboxylesterases).

Protocol:

- Spike Test Compound (1 M) into pooled plasma (Human/Rat) pre-warmed to 37°C.
- Incubate in a shaking water bath.
- Sample at min into ice-cold ACN + IS.
- Analyze via LC-MS/MS.

Strategic Application in Drug Design

When to use Linear Thiophene Esters:

- Soft Drug Design: When you want the drug to be rapidly inactivated after acting locally (e.g., topical dermatological agents, inhaled drugs with low systemic exposure).
- Prodrug Activation: If the ester must be cleaved to release the active acid (e.g., similar to Clopidogrel activation, although Clopidogrel's ester hydrolysis is actually an inactivation pathway).

When to use Gem-Dimethyl Thiophene Esters:

- Oral Bioavailability: To prevent "first-pass" hydrolysis in the intestine and liver, ensuring the intact ester reaches systemic circulation.
- Brain Penetration: Esters are more lipophilic than acids. Protecting the ester allows it to cross the Blood-Brain Barrier (BBB) before oxidative metabolism occurs.

References

- Beaumont, K., et al. (2003). Design of ester prodrugs to enhance oral absorption of poorly permeable compounds: challenges to the discovery scientist. *Current Drug Metabolism*.
- Lavis, L. D. (2008). Ester bonds in prodrugs.[1] *ACS Chemical Biology*.
- Buchwald, P. (2020). Soft drugs: design principles, success stories, and future perspectives. *Expert Opinion on Drug Metabolism & Toxicology*.
- Fukami, T., & Yokoi, T. (2012). The emerging role of human esterases. *Drug Metabolism and Pharmacokinetics*. [1][2][3][4]
- Di, L., & Kerns, E. (2016). *Drug-Like Properties: Concepts, Structure Design and Methods*. Elsevier.[5] (Chapter on Metabolic Stability).

Need Custom Synthesis?

BenchChem offers custom synthesis for rare earth carbides and specific isotopic labeling.

Email: info@benchchem.com or [Request Quote Online](#).

Sources

- 1. [Effects of steric hindrance and electron density of ester prodrugs on controlling the metabolic activation by human carboxylesterase - PubMed \[pubmed.ncbi.nlm.nih.gov\]](#)
- 2. [nedmdg.org \[nedmdg.org\]](http://nedmdg.org)
- 3. [longdom.org \[longdom.org\]](http://longdom.org)
- 4. [labtesting.wuxiapptec.com \[labtesting.wuxiapptec.com\]](http://labtesting.wuxiapptec.com)
- 5. [researchgate.net \[researchgate.net\]](http://researchgate.net)

- To cite this document: BenchChem. [Metabolic stability of gem-dimethyl thiophene esters vs linear esters]. BenchChem, [2026]. [Online PDF]. Available at: [<https://www.benchchem.com/product/b2415886/docs#metabolic-stability-of-gem-dimethyl-thiophene-esters-vs-linear-esters>]

Disclaimer & Data Validity:

The information provided in this document is for Research Use Only (RUO) and is strictly not intended for diagnostic or therapeutic procedures. While BenchChem strives to provide accurate protocols, we make no warranties, express or implied, regarding the fitness of this product for every specific experimental setup.

Technical Support: The protocols provided are for reference purposes. Unsure if this reagent suits your experiment?

Need Industrial/Bulk Grade? [Request Custom Synthesis Quote](#)

BenchChem

Our mission is to be the trusted global source of essential and advanced chemicals, empowering scientists and researchers to drive progress in science and industry.

Contact

Address: 3281 E Guasti Rd
Ontario, CA 91761, United States
Phone: (601) 213-4426
Email: info@benchchem.com

[Contact our Ph.D. Support Team for a compatibility check](#)